



Modeling of fatigue crack propagation using dual boundary element method and Gaussian Monte Carlo method

F.R.M. Romlay^{a,*}, H. Ouyang^{b,1}, A.K. Ariffin^{c,2}, N.A.N. Mohamed^{c,3}

^a Faculty of Mechanical Engineering, Universiti Malaysia Pahang, PO Box 12, 25000 Kuantan Pahang, Malaysia

^b Department of Engineering, University of Liverpool, The Quadrangle, Liverpool L69 3GH, England, UK

^c Faculty of Engineering, Universiti Kebangsaan Malaysia, Bangi, 43600 Selangor, Malaysia

ARTICLE INFO

Article history:

Received 13 December 2008

Accepted 1 September 2009

Available online 18 November 2009

Keywords:

Crack propagation

Fatigue

Gaussian

Monte Carlo

Dual boundary element method

Deterministic

Probabilistic

ABSTRACT

This paper studies the modeling of fatigue crack propagation on a multiple crack site of a finite plate using deterministic and probabilistic methods. Stress intensity factor has been calculated by the combined deterministic approach of the dual boundary element method (DBEM) and the probabilistic approach of the Gaussian Monte Carlo method. The Gaussian Monte Carlo method has been incorporated to simulate the random process of the fatigue crack propagation. A finite plate of aluminum alloy 2024-T3 with a thickness of 1.6 mm and 14 holes is analyzed and the fatigue life of the plate is predicted by following a linear elastic law of fracture mechanics. The results of fatigue life predicted by DBEM-Monte Carlo method are in good agreement with experimental ones. The same approach is also applied to two other engineering applications of a gear tooth and a bracket.

Crown Copyright © 2009 Published by Elsevier Ltd. All rights reserved.

1. Introduction

Probabilistic methods as a stochastic concept are a new approach of modeling fatigue crack propagation and they have several advantages over deterministic methods. One of the probabilistic methods is randomizing the coefficients of an established deterministic model to consider, for example, inhomogeneity of materials [1]. Probabilistic data are generated by a random process of multiple dynamic characteristics of fatigue crack growth in this investigation.

In the area of fatigue analysis, an estimation of failure probability is required. A failure contains probabilistic characteristics because of uncertainties in the location of initial cracks, material properties, applied loads and possible flaws in the material or structure. Manufacturing defects like poor surface roughness, scratches or weld defects also contribute to the uncertainties of a failure [2]. As a crack grows, the crack size varies according to those uncertainty parameters. Moreover, dynamic factor is one of the reasons why a deterministic method is not accurate for crack modeling in a structure. The residual life of a structure appears as a dynamic character and varies with

time. Fatigue crack propagation is inherently a random process because of the inhomogeneity of material, which is related to its crystal structure and variations of molecules movement due to unit cell arrangement and other similar causes [3].

Fatigue degradation caused by a flaw still allows a structure to continue operating properly even in the event of the failure of some of its uncritical components. However, there is a possibility for a flaw to initiate crack propagation during operation of a structure. Therefore, a probabilistic method is normally used for estimating the failure probability of a component subject to degradation, as mentioned by Cadini et al. [4].

In addition to the material factor, service conditions also play a main role in crack growth rate. Factors such as temperature and other uncontrolled variables contribute to variability in experimental data of kinetic energy during fatigue crack growth. That is why crack propagation is considered a random process.

A stochastic model considering all types of variability is thus needed for the rational assessment of fatigue crack propagation. Therefore, the analysis of fatigue crack propagation should be based on the probabilistic approach in order to consider uncertain factors.

There are several parameters used to measure crack growth in fracture mechanics. Effective stress intensity factor, K_{eff} is one of the parameters that represent the level of crack propagation. Stress intensity factor as a failure criterion depends on sample geometry, the size and location of the crack and the load distribution. They are subjected to variations and considered random variables. The failure probability is considered high if the value of K_{eff} exceeds the critical value K_{ic} . In short term, normally

* Corresponding author. Tel.: +60 954 92219; fax: +60 954 92244.

E-mail addresses: fadhlor@ump.edu.my (F.R.M. Romlay), h.ouyang@liverpool.ac.uk (H. Ouyang), kamal@eng.ukm.my (A.K. Ariffin), enikkei@eng.ukm.my (N.A.N. Mohamed).

¹ Tel.: +44 151 7944815; fax: +44 151 7944848.

² Tel.: +60 389216517; fax: +60 389216145.

³ Tel.: +60 389216503; fax: +60 389216145.

large cracks dominate in the failure probability at the beginning of failure stage. However, in long term, small cracks may have the dominant influence on the failure probability. This creates uncertainty in determine the location of the failure. The failure probability for crack locations with K_{eff} in failure range can be estimated by DBEM-Monte Carlo method.

The special interest in the probabilistic approach lies in its significant advantages over the deterministic approach for structural integrity assessments. The state of damage of a structure in terms of probability density function (PDF) is one feature of the probabilistic approach [5]. This approach affords information on fatigue life because it expresses safe-life and damage tolerance characteristics. The time taken by and cost required of this method are lower compared with the experimental approach used in the past. So it is an efficient and useful technique for assessment of a structure's life.

This paper presents the development of an assessment program for the fatigue crack propagation in order to determine the fatigue life of a structural component. Initial crack scenarios are randomly defined by a probabilistic approach and crack evolution has been simulated through a deterministic approach using DBEM incorporating a fracture mechanics law [6]. The stress intensity factor value, K , is provided by the DBEM after given inputs are processed. For multi-site cracks, a probabilistic approach of the Monte Carlo method is used by Kebir et al. [6] only to identify the crack sites locations for crack propagation increment base on effective stress intensity factor value, K_{eff} . Then, the crack magnitude is determined by fully deterministic approach. In addition to the Kebir et al.'s [6] works, the Monte Carlo modeling of fatigue crack propagation is expended for predicting crack growth magnitude by randomizing the DBEM calculations and this is the originality of this paper.

2. Law of fatigue crack propagation

Paris and Erdogan [7] in 1963 put forward the Paris law shown in Eq. (1) and it is still in use today

$$\frac{da}{dN} = C(\Delta K)^m \quad (1)$$

where da is crack growth and dN is the number of stress cycle. Stress intensity range, ΔK equal to $K_{\text{max}} - K_{\text{min}}$, where K_{max} and K_{min} denote the maximum and minimum values of effective stress intensity factor respectively. C and m are parameters related to material properties.

The stress concentration factor is one of the parameter widely used in linear elastic fracture mechanics. The theory is valid if no yielding happens at the crack tip. Therefore, Eq. (1) can be used for only high cyclic fatigue cases. Forman et al. [8] tried to modify Eq. (1) to include the stress concentration ratio $R = K_{\text{min}}/K_{\text{max}}$ and the fracture strength K_c . Re-writing $\Delta K = K_{\text{max}}(1 - R)$ and taking K_{max} as K_c , the limit condition for fatigue crack propagation is defined as follows:

$$\lim_{\Delta K \rightarrow (1-R)K_c} \frac{da}{dN} = \infty \quad (2)$$

Substitution of Eq. (2) into (1) yields

$$\frac{da}{dN} = \frac{C(\Delta K)^m}{(1-R)K_c - \Delta K} \quad (3)$$

Forman et al. [8] gave $m=3$ for aluminum alloy 7075-T6 in Eq. (3), known as Forman equation. Starting from Forman equation and considering that the crack will not propagate if ΔK is below the threshold value of stress intensity range, ΔK_{th} as shown in Fig. 1 [9], a fatigue crack growth rate law can be derived

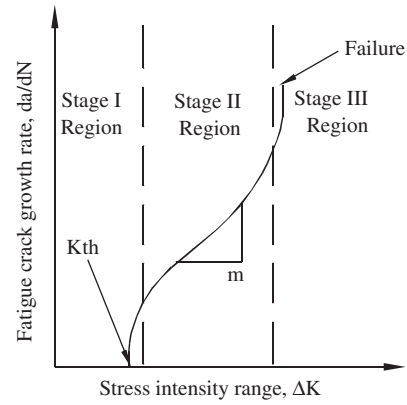

Fig. 1. Scheme diagram of short and long fatigue crack propagation [9].

and is given as follows:

$$\frac{da}{dN} = C \left(\frac{\Delta K - \Delta K_{\text{th}}}{K_c - K_{\text{max}}} \right)^2 + C' \quad (4)$$

This equation is valid for soft metals under both constant-amplitude cyclic loading and random loading. C' was found to be close to 2.4×10^{-7} mm/cycle [8].

Crack behavior is determined by the values of the stress intensity factor which is a function of the applied load and geometry of the crack and the structural component. The crack propagation process is modeled by performing a crack growth calculation. The stress intensity factor is evaluated and the crack path is defined in terms of the stress intensity factor.

3. Linear elastic fracture mechanics

Fracture mechanics seeks to establish the local stress and strain fields around a crack tip in terms of global parameters. The local stress and strain exist because of presence of a crack. Linear elastic characteristics are used in crack path model. The cracks are subjected to constant-amplitude cyclic loading. For linear elastic solutions, the stresses in the vicinity of the crack are defined by stress intensity factor.

Wöhler curve assumes that the average fatigue life N_i at a certain point of aluminum alloy 2024-T3 is

$$N_i = 10^5 \left(\frac{S_m - S_{\text{lim}}}{IQF - S_{\text{lim}}} \right)^p \quad (5)$$

where S_m is average stress, $p=2.28$, $IQF=176$ MPa, and $S_{\text{lim}}=59$ MPa.

In linear elastic fracture mechanics, there are several mixed mode propagation criteria. One of them is stress intensity factor that controls the near tip stress field. Magnitude of the crack tip stress, σ_{11} is governed by the mode I stress intensity factor, K_I and mode II stress intensity factor K_{II} as shown in Eq. (6) where subscripts I and II refer to directions. It is also observed that the shear modulus, μ is influenced by the stress intensity factor too, as shown in Eq. (7). The stress distribution is described by the position relative to the crack tip given by polar coordinates r and θ

$$\sigma_{11} = \frac{K_I}{\sqrt{2\pi r}} \cos \frac{\theta}{2} \left(1 - \sin \frac{\theta}{2} \sin \frac{3\theta}{2} \right) - \frac{K_{II}}{\sqrt{2\pi r}} \sin \frac{\theta}{2} \left(2 + \cos \frac{\theta}{2} \cos \frac{3\theta}{2} \right) \quad (6)$$

$$\mu = \frac{1}{4u} \sqrt{\frac{r}{2\pi}} \left[K_I \left((2k-1) \cos \frac{\theta}{2} - \cos \frac{3\theta}{2} \right) + K_{II} \left((2k+3) \sin \frac{\theta}{2} + \sin \frac{3\theta}{2} \right) \right] \quad (7)$$

K_I and K_{II} are used to calculate the stress intensity factor near the tip of a crack. This formula applies to opening mode cracks where tensile loads are applied in the direction normal to the plane of the crack, as in this paper. Two-dimensional numerical stress analysis is carried out using DBEM for plane-stress and plane-strain problems. DBEM is well suited for crack problems by modeling only the boundaries of the model.

4. Dual boundary element method (DBEM)

The DBEM is a numerical computational method of solving linear partial differential equations which have been formulated as integral equations. DBEM is used in crack modeling because of the single-region ability which is not required any remeshing work during the analysis [10]. In order to create the DBEM super-element stiffness matrix for a cracked domain, an algorithm based on DBEM is applied. DBEM is a useful technique for treating the volume integral without discretising the volume. The technique approximates part of the integrand using local interpolating functions and converts the volume integral into boundary integral after collocating at selected points distributed throughout the volume domain. In DBEM, although there is no need for the volume to be discretised into meshes, unknowns at chosen points inside the solution domain are involved in the linear algebraic equations approximating the problem being considered.

Edges of the crack are modeled as discontinuous function and crack-tip is modeled by singular elements that exactly represent the strain field singularity $1/\sqrt{r}$. The discontinuous function represented by generalized Heaviside step function at crack edges is an enrichment for discontinuous fields, referred to as extended finite element method. The function allow the domain to be modeled using DBEM without explicitly meshing the crack surfaces [11]. In the study of cracks, internal edges or surfaces that include no area or volume and share the same coordinates before applying the forces are modeled by coincident vectors as crack elements. Vectors can be said coincident when their directions are the same though the magnitude may be different. For symmetric crack problems, only one of the edges of the crack needs to be modeled and a single-region dual boundary element analysis may be used.

However, solutions of general crack problems cannot be achieved in a single-region analysis with direct application of the DBEM, as it is based on the coincident vectors. Coincident vectors with the same coordinate are discretised throughout the single edge before the load is applied. Then, the edge splits into two to simulate the crack opening with the stresses applied to both side of a crack, thus resulting in more than one singular system of algebraic equations. In other words, the crack is presented in different types of singularity because of the presence of two coincident points on both sides of a crack. The DBEM is formulated by representing one of the crack edges with displacement component, U and on the other edge with the traction component, T in separated boundary integrals. Both integrals are incorporated together in Eq. (8).

In order to solved the coincidence problem, the Langrarian continuous or discontinous dual boundary element is used to satisfied Cauchy principal value integral which is defined in displacement equation. At the same time, the different types of singularity in a crack problem are solved by using the Hadamard finite part integral before it can be integrated with DBEM as a solution method. Extended from the Hadamard principal-value integral, the traction equation is defined. The DBEM is adopted in which the displacement and traction boundary integrals are associated as follows:

$$u_i(x') = \int_{\Gamma} U_{ij}(x',x)t_j(x) d\Gamma(x) - \int_{\Gamma} T_{ij}(x',x)u_j(x) d\Gamma(x) \tag{8}$$

where $U_{ij}(x',x)$ and $T_{ij}(x',x)$ in Eq. (8) are displacement and Kelvin traction of a point x in domain Γ . $|x-x'|$ defines the distance between the source point x' and the field point x . t represents a traction component, u represents displacement component and subscript i and j denote Cartesian components.

By considering the crack element singularity caused by the coincident points on both sides of a crack, crack modeling is presented in the J -integral function, which is a way to calculate the strain energy release rate per unit fracture surface area in a material and it is given by

$$J = (Wn_1 - t_j u_{j,1}) ds \tag{9}$$

where s is an arbitrary contour surrounding the crack tip, W is the strain energy density, given by $1/2\sigma_{ij}\epsilon_{ij}$, where σ_{ij} and ϵ_{ij} are the stress and strain tensors, respectively, t_j is traction components given by $\sigma_{ij}n_i$, where n_i are the components of the outward unit vector component normal to the contour path. The relationship between the J -integral and the stress intensity factor are given by

$$J = \frac{K_I^2 + K_{II}^2}{E'} \tag{10}$$

where E' equals to E (Young's modulus) for plane-stress conditions and equals to $E/(1-\nu^2)$ for plane-strain conditions. The total J -integral is represented by the sum of two integrals in different directions as follows:

$$J = J_I + J_{II} \tag{11}$$

By using DBEM, a stress analysis of the structure has been performed where stress intensity factors are computed by the J -integral technique after the displacement and traction boundary integral equation is solved [12]. The direction of the crack-extension increment is also computed through the deterministic approach.

5. Probability approach of Monte Carlo method with Gaussian distribution function

Monte Carlo methods are useful for modeling phenomena with significant uncertainty in inputs, such as the calculation of parameters for multi-site damage simulation. These methods are also widely used in mathematics: a classic use is for the evaluation of definite integrals, particularly multidimensional integrals with complicated boundary conditions. These advantages are fully utilized in fatigue crack propagation simulation through an application of Monte Carlo estimator that provides good estimation for crack parameter calculation. The underlying mechanisms of random crack propagation simulation start by applying a random number in mathematical equation. If ξ_1, \dots, ξ_n are independent random numbers and range between 0 and 1, then,

$$f_i = f(\xi_i) \tag{12}$$

is an independent variable. However, this variable is different from the Monte Carlo estimator, $\theta(f(\xi_i))$, where θ is considered as a function of random variable ξ having probability of greater than zero on a set of values L and is given as follows:

$$\theta(f(\xi)) = \int_{\xi \in L} f(\xi) d\xi \tag{13}$$

where $\xi \in L^2(0,1)$ is greater than zero. The mean of function $f(\xi_i)$ is computed as follows:

$$\tilde{f}_n(\xi) = \frac{1}{n} \sum_{i=1}^n f(\xi_i) \tag{14}$$

where n is the sample quantity. In this study, n -sample of ζ 's, $(\zeta_1, \dots, \zeta_n)$ are taken into account.

A number of Monte Carlo estimators may be proposed and typically, a better Monte Carlo estimator has smaller variance for the same amount of computational effort than its competitors. The variance is calculated as

$$\text{Var}(\tilde{f}_n(\zeta)) = \frac{1}{n} \int_{\zeta \in L} [f(\zeta) - \theta(f(\zeta))]^2 d\zeta = \frac{\sigma^2}{n} \quad (15)$$

The standard deviation of Monte Carlo estimator, $\sigma_{\tilde{f}}$ is expressed in terms of standard deviation of n -sample, σ as follows:

$$\sigma_{\tilde{f}} = \frac{\sigma}{\sqrt{n}} \quad (16)$$

However, in practice, the real standard deviation does not exist. So, the only way to estimate the sample variance, σ^2 is

$$\sigma^2 = \frac{1}{n-1} \sum_{i=1}^n (f_i - \bar{f})^2 \quad (17)$$

If the Monte Carlo method is used for only once, the mean and effectiveness ratio, defined in Eq. (18), will not change. However, there will be a change in the mean and effectiveness ratio when the Monte Carlo method is used repeatedly. The effectiveness ratio of using the Monte Carlo method twice in a single simulation is expressed as

$$\text{Effectiveness ratio} = \frac{n_1 \sigma_1^2}{n_2 \sigma_2^2} \eta \quad (18)$$

where n_1 and n_2 are the numbers of sample used in first and second rounds of applying the Monte Carlo method, respectively, σ^2 is a variances and η is a constant weighting parameter.

In any case study of fatigue crack propagation, the effectiveness ratio is the product of variance ratio, σ_1^2/σ_2^2 and work ratio, n_1/n_2 . The variance ratio is only influenced by the Monte Carlo method while the work ratio is influenced by both the Monte Carlo method and error in computation due to poor-quality or missing data.

Crack profiles are probably generated for any side of the notches presented. However, the crack propagation still mainly influenced by SIFs value, as mentioned in Equation (1). The SIFs, which are depended to the force applied and geometry properties of the crack are assumed to be distributed in Gaussian form. The Gaussian distribution function, $f_g(x)$ is given in Equation (19) below:

$$f_g(x) = \frac{1}{\sqrt{2\pi\sigma^2}} e^{-\frac{(x-\alpha)^2}{2\sigma^2}} \quad (19)$$

where α is a mean value of n number of samples and p is a probability of any integer value of x and relates each other with the equation below:

$$\alpha = np \quad (20)$$

The Gaussian distribution function may be used to describe physical events. The Gaussian distribution is a continuous function which approximates the exact binomial distribution of events. The Gaussian distribution is normalized so that the sum over all values of x gives a probability of 1.

6. Crack modeling strategy

In this study, the spatial domain was modeled as a boundary super-element by BEASY [12]. It is necessary to calculate the relation between stiffness matrix and effective stress intensity factor, K_{eff} by DBEM, as follows:

- Carry out a DBEM for stress analysis of the structure.

- Compute the K_{eff} with the J -integral technique.
- Choose crack site to be propagated through the Monte Carlo method.
- Compute the direction of the crack growth.
- Extend the crack propagation length determined by the Monte Carlo method along the direction computed in the current step.
- Compute the crack cycle using Gaussian and non-Gaussian Monte Carlo Method.
- Repeat all the steps above sequentially until a failure limit exceed.

The DBEM super-element stiffness matrix and K_{eff} , after consideration, has been inserted into crack initialisation routine and also into crack propagation routine by the Monte Carlo method in MATLAB source code. The Woehler's curve at 50% of the stress level of 165 MPa was applied to determine the life cycle for the initial iteration. By running the Monte Carlo method through a MATLAB program for 500 samples, it is possible to see how long crack propagation takes, which are given by the number of life cycles, N . This process is operated by randomizing a sampling set

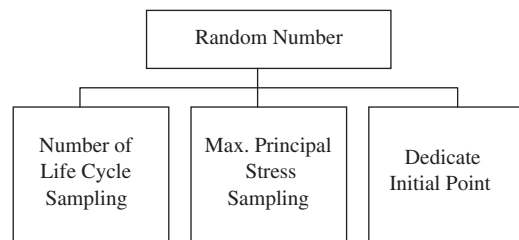

Fig. 2. Random parameter for fatigue crack propagation.

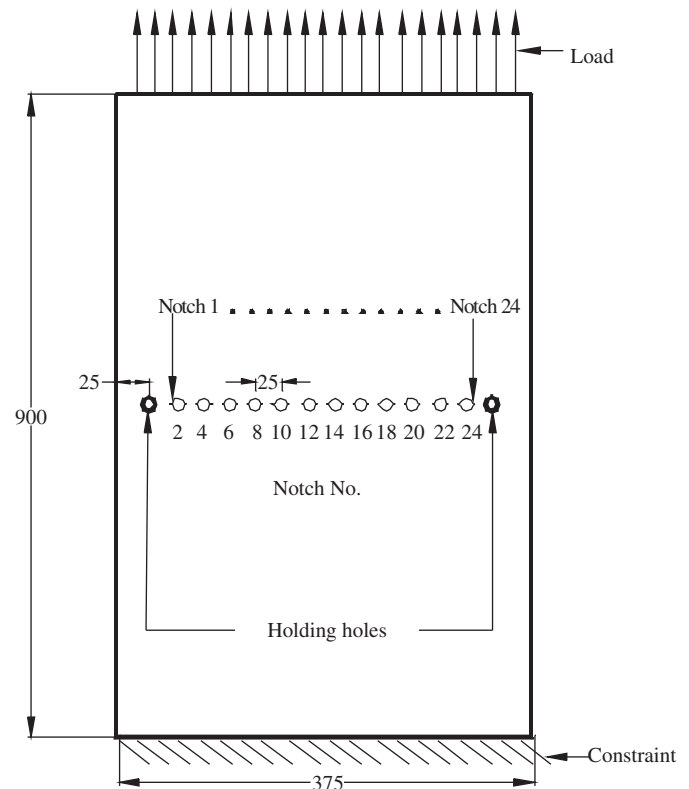

Fig. 3. Schematic diagram of plate with 14 holes and with geometry dimensions in mm unit. Detail of notches geometry is illustrated in Fig. 5.

of life-cycle quantity. The length of a crack growth is based on maximum principal stress, σ_{max} value while the initial location where a crack starts to grow is determined by a random process shown in Fig. 2. The modified data files in BEASY are used to produce an updated data set. Prediction of the crack position and length are randomly generated via Monte Carlo modeling. The modeling using Gaussian and non-Gaussian distribution of the mean crack length as a function of crack cycle are performed. n number of samples are used in order to perform the modeling. The mean and standard deviation are defined to proceed with Gaussian distribution function. The effect of Gaussian distribution in Monte Carlo modeling is discussed and summarized.

7. Numerical results

7.1. Plate with 14 holes

In order to validate the global probabilistic approach, DBEM-Monte Carlo results are compared with the fatigue test results on a plate with 14 holes that was conducted by Kebir et al. [6] at Aerospatiale-Matra Laboratory in Suresnes, France. The plate was a 2-D 900 mm \times 375 mm rectangle fully constrained at the bottom

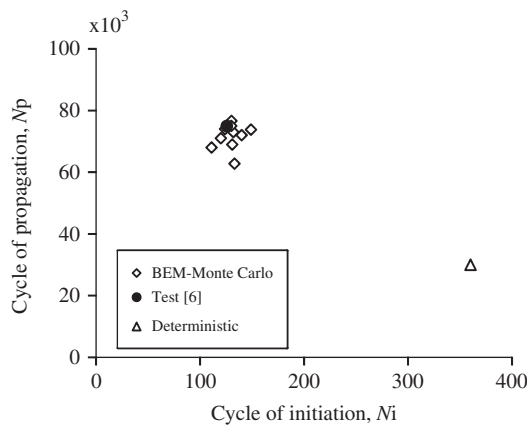

Fig. 4. Fatigue life.

edge as shown in Fig. 3. The load was applied in the vertical direction. The material was aluminum alloy 2024-T3 sheet with a thickness of 1.6 mm. Young's modulus of the sample was 72.7 GPa.

The initial structure was discretised by 262 elements, with 1202 degrees of freedom. It had 897 internal points which are laid along the boundary line that encloses region of the model. The fatigue test results [6] were compared with the numerical results and a small difference was found. The total numbers of life cycles, N_{Total} for multi-site cracks predicted by the DBEM-Monte Carlo method are close to the test results [6], as depicted in Fig. 4.

In the deterministic approach, propagation iteration is short with 30×10^3 cycles for multi-site cracks. It is because all the cracks are assumed to begin at the same time, since all the edges are undergoing the same stress level. However, the probabilistic approach has an advantage of revealing initial crack propagation. The synthesis of the probabilistic results is expressed in Fig. 5. Several large cracks dominate the failure probability at the beginning of the failure process. But in long term, any small cracks size may have the most dominant effect on the failure probability. This is because, not all the large cracks which propagate at the notch with maximum principle stress, σ_{max} cause failure since failure is independent of σ_{max} . The failure

Table 1
Results of fatigue crack propagation.

Iteration	Crack length (10^{-3} mm)	Gaussian distribution function $f_g(x)$ (10^{-2})	Cycle N_{Total} (10^5)	Point no.
1	0.0056	2.55	0.2957	7
2	0.1702	3.81	0.3058	2
3	0.1034	3.17	0.3985	1
4	0.3706	9.68	0.4319	1
5	0.2498	5.02	0.5012	1
6	0.2077	4.30	0.6541	11
7	3.5293	41.7	0.7354	14
8	0.2219	4.52	1.2595	14
9	0.2557	5.15	1.3871	12
10	0.6363	9.32	1.4735	13
11	0.1043	3.18	1.5108	16
12	0.1557	3.65	1.7244	21
13	Failure	-	1.9825	21

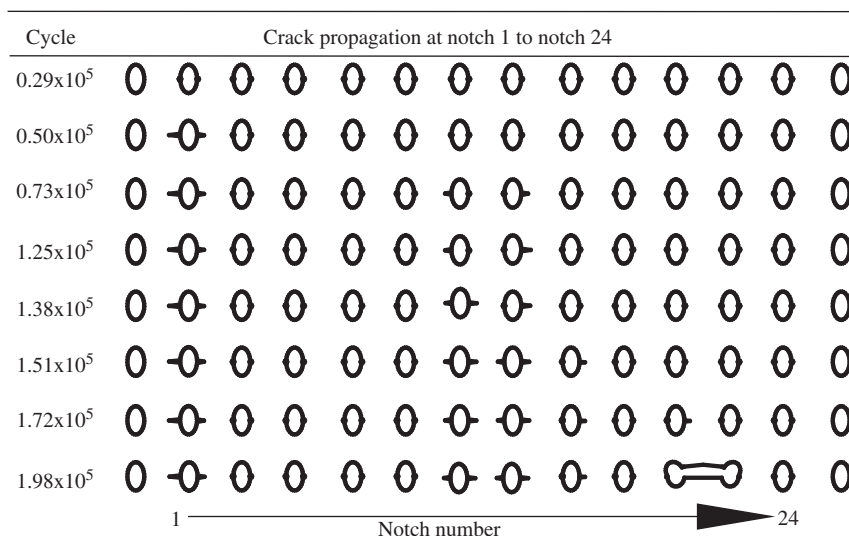

Fig. 5. Life cycle of fatigue crack propagation by iterations.

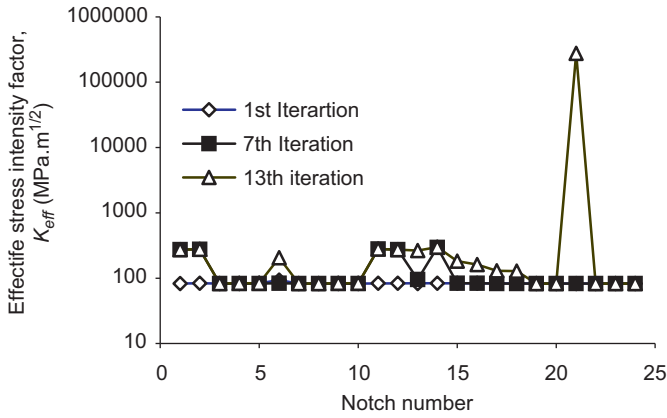

Fig. 6. Graph of effective SIF versus notches number for 1st, 7th and 13th iteration.

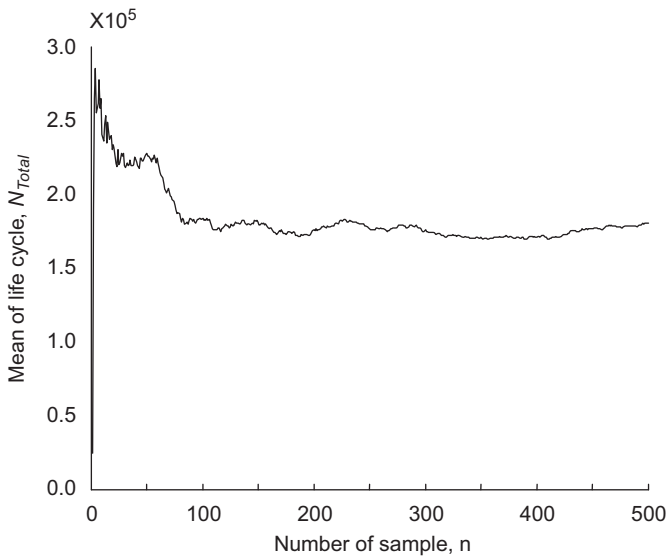

Fig. 7. Mean life cycle versus number of sample for 13th iteration.

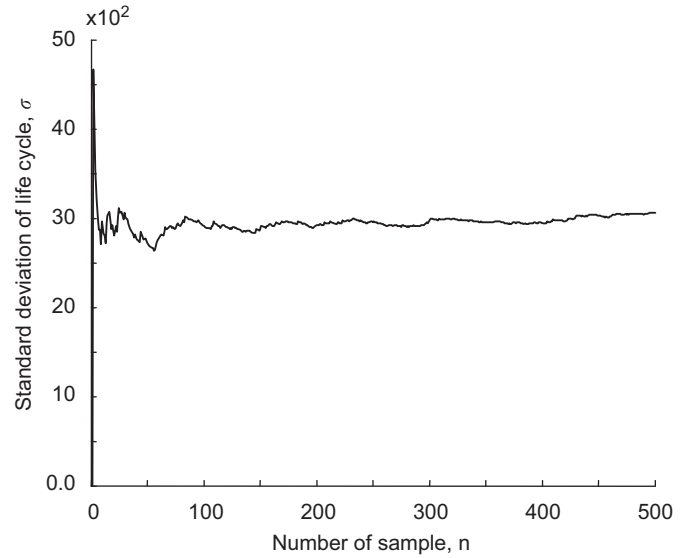

Fig. 8. Standard deviation of life cycle versus number of sample for 13th iteration.

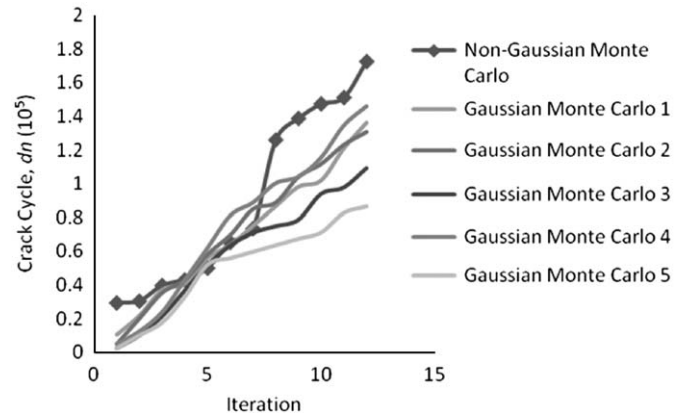

Fig. 9. Crack cycle prediction using non-Gaussian and Gaussian Monte Carlo method.

criterion is based on K_{eff} which depends on sample geometry, the size and location of the crack and the load distribution. K_{eff} must be higher than the critical value of stress intensity required, K_{ic} in order to allow failure to occur. Failure simply occurs just when K_{eff} of any small cracks reaches the values that are slightly higher than K_{ic} . However, the presence of uncertain parameters in real applications might be another cause of failure [6]. That is why multi-site cracks propagate in a quite long time and the calculation of the cracks length, da takes many iterations.

Table 1 shows the maximum crack length just before failure which is 3.5293 mm. At this moment, the number of life cycle is only 0.7354×10^5 predicted at the 7th iteration. It happened because the crack of notch 14 had enough energy to initiate the propagation. The propagation of the cracks happened very fast. However, the failure of the sample did not happened yet until the life cycle reached 1.9825×10^5 cycles.

Any notches that allow initial cracks to form may increase K_{eff} . The K_{eff} values are constantly increasing in several initial iterations, until they achieve a constant value defined as the maximum K_{eff} . For the plate with fourteen holes, notch numbers 1, 2, 11, 12 and 14 are found to produce an initial crack as shown in Fig. 6. The cracks growths continue for certain more iterations. After that, the cracks randomly propagate at any notches, including the notches which have a lower K_{eff} (but higher than K_{ic}).

In this scenario, the cracks pass through notches number 6, 15, 16, 17, 18 randomly. The cracks continue to propagate for certain iterations until any of them reach the maximum K_{eff} . The extensive crack propagation can cause the sample to fail at any time. Notch number 21 is found to have a catastrophic failure when its K_{eff} reaches 276,659.75 $\text{MPa}\cdot\text{m}^{1/2}$ at the 14th iteration. This happens due to the increment of high potential energy at notch 21, where K_{eff} , even though is low, exceeds K_{ic} at the 7th iteration. So, failure occurs randomly according to DBEM-Monte Carlo method, reflecting the uncontrolled uncertainties in modeling work. Uncertainties are taken into account because they are able to affect the fatigue crack propagation process in real applications.

Figs. 7 and 8 show the mean life and standard deviation predicted at the 10th iteration. It is seen that the number of samples in the Monte Carlo simulation influences fatigue life. The results become constant when the number of samples is over 300. So the DBEM-Monte Carlo combined method is able to produce a statistical value. The mean life and standard deviation predicted at other iterations are found to give the same result as the 10th iteration.

The values of the Gaussian distribution function at certain crack length and the standard deviation are given in the Table 1. For these conditions, the mean crack length is $5.01\text{E-}4$ mm. Major

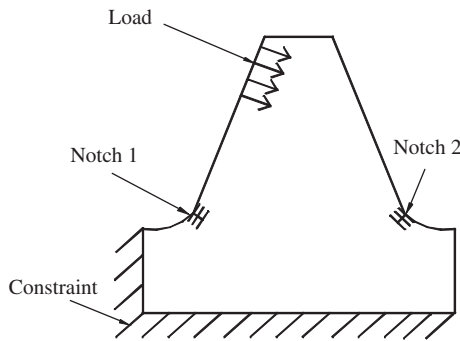

Fig. 10. Gear tooth with its boundary condition.

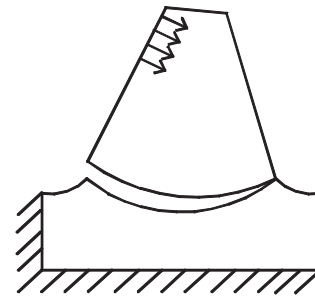

Fig. 12. Failure of the gear tooth.

Table 2
Life cycle and crack size of gear tooth by Monte Carlo analysis.

Iteration no.	Crack length (10 ⁻³) (mm)	Notch no.	N _{Initiation} (10 ³)	N _{Propagation} (10 ³)	N _{Total} (10 ³)
1	0.3862	1	0.2840	35.7596	0.6416
2	7.9654	1	0.7782	8.6242	0.8645
3	0.4273	2	0.9752	0.3350	0.9786
4	4.7054	1	0.9967	4.2570	1.0393
5	(Failure)	1	1.0594	6.8270	1.1277

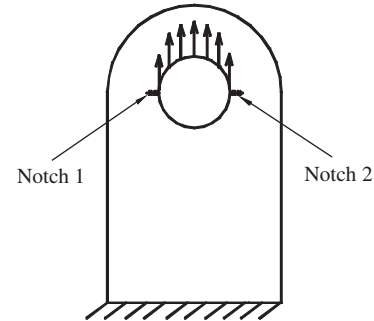

Fig. 13. Bracket with its boundary condition.

Table 4
Life cycle and crack size of bracket by Monte Carlo analysis.

Iteration no.	Crack length (10 ⁻³) (mm)	Notch no.	N _{Initiation} (10 ⁵)	N _{Propagation} (10 ³)	N _{Total} (10 ⁵)
1	0.6852	2	0.9240	12.594	1.1527
2	1.2000	2	1.1548	5.8611	1.2134
3	1.2000	2	1.2394	6.7017	1.3064
4	2.3000	2	1.3424	4.6257	1.3887
5	107.00	2	1.4524	5.6059	1.4631
6	193.54	2	1.4653	0.3264	1.4685
7	Failure	2	1.4952	1.3358	1.5092

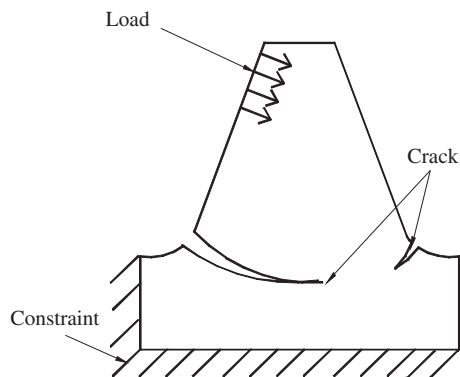

Fig. 11. Notch was propagate to be a crack.

Table 3
Life cycle of gear tooth by deterministic approach.

Iteration no.	Crack length (10 ⁻³) (mm)	Notch no.	N _{Initiation} (10 ⁴)	N _{Propagation} (10 ⁴)	N _{Total} (10 ⁴)
1	Failure	1	4.5411	2.0573	6.5984

influence of crack propagation is still stress intensity factor, even uncertainties are considered. To this reason, Gaussian stress intensity factor is considered in order to drive the crack propagation prediction more accurately, based on the notch presented. So, the Monte Carlo simulation for Gaussian SIF is proceeded to obtain the crack cycle. The results are compared with crack cycle of non-Gaussian Monte Carlo as depicted in Fig. 9. It is clearly that, the Gaussian Monte Carlo is appropriated for the crack cycle prediction in structure durability.

7.2. Gear tooth

The same method is applied to a gear tooth shown in Fig. 10. The constraint is at the bottom edge that represents contact line

with the shaft. Two notches are made on the left and right sides and named notch 1 and notch 2. The results are listed in Table 2. Fig. 11 illustrates the major crack at notch 1. This is due to the stress occurring at the left side by considering the real loading situation when a gear is operating. However, because of the small variation of stress intensity factor in the random process, a very small crack also occurs at notch 2 in the 3rd iteration from the simulation.

Next, fatigue crack propagation of the same gear tooth is simulated by a fully deterministic approach. The results in Table 3 show that the crack propagation happens in a single iteration. Failure happens after reaching 6.5984 × 10⁴ cycles. The geometry of the crack is illustrated in Fig. 12. The crack propagates at the notch with maximum principle stress, σ_{max}. That is why the crack propagation happens very fast and the calculation of the crack length, da is finished within a single iteration. This reveals that a fully deterministic method cannot provide the characteristics of a random process.

7.3. Bracket

The analysis of fatigue crack propagation is continued for a metal bracket shown in Fig. 13. The constraint is applied at the bottom edge of the plate. Load is applied downward at the top half

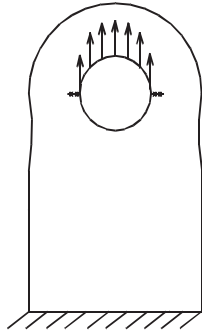

Fig. 14. $N_{\text{Total}} = 1.1527 \times 10^5$ cycles.

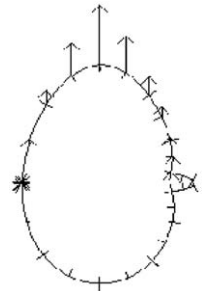

Fig. 15. $N_{\text{Total}} = 1.3887 \times 10^5$ cycles.

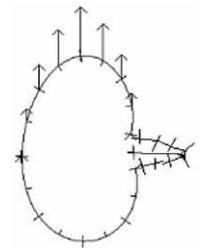

Fig. 16. $N_{\text{Total}} = 1.4631 \times 10^5$ cycles.

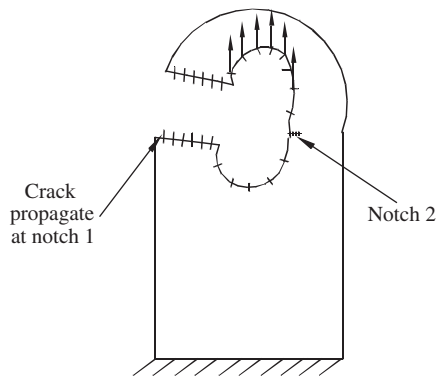

Fig. 17. Bracket with crack propagation at notch 1.

Table 5

Life cycle of bracket by deterministic approach.

Iteration no.	Crack length (mm)	Notch no.	$N_{\text{initiation}} (10^4)$	$N_{\text{propagation}} (10^4)$	$N_{\text{Total}} (10^4)$
1	Failure	1	8.2669	3.3001	11.567

bracket fails when the number of life cycle increases by about 3.3001×10^4 cycles, as shown in Table 5. This propagation process is modeled by a single iteration, i.e., without any random process.

8. Conclusion

A method has been developed to assess the fatigue crack propagation with the implement of probabilistic approach of the Monte Carlo method. The results from the combined dual boundary element and Gaussian Monte Carlo analysis show that the life cycle of several structural components can be predicted and the predicted life cycle of a plate with 14 holes is in good agreement with the experimental results.

The notches existing initially in those components have a tendency to initiate cracks randomly. The cracks continue to propagate for a certain number of cycles until any of the cracks reach the maximum K_{eff} . The increase of the fatigue life means cracks continue to grow. Extensive crack propagation will cause a catastrophic failure of the component.

The model in this work suggests that the length of the crack growth based on K_{eff} must be incorporated as a random variable. The notch with the highest K_{eff} value does not necessarily produce the longest crack. This is proven by the life-cycle simulation results of the fatigue crack propagation through DBEM-Gaussian Monte Carlo method conducted in this research and is more accurate compare to the results obtained from DBEM only. Sometimes, the probability to produce a longer crack at a location with low K_{eff} (but higher than K_{ic} , which is the minimum failure criterion), is very high. This happens due to the random nature of the simulated crack propagation process, which reflects real applications and is modeled by DBEM-Gaussian Monte Carlo method. Some scenarios show that, a crack that is smaller at the beginning could be the critical one causing structural failure. A big crack at the beginning sometimes is not at the critical location. This is where the Monte Carlo method plays a key role in bringing the uncertainties into modeling work. However, it must be made clear that the low K_{eff} must exceed K_{ic} to cause crack propagation, which is the criterion of crack propagation considered in this paper.

From the study, the results show that the Gaussian Monte Carlo method provides a better crack monitoring model compare to non Gaussian Monte Carlo. The initial results, provided by both non - Gaussian and Gaussian Monte Carlo method are quite similar. However, starting from the middle to the end of simulation process, Gaussian Monte Carlo propose a lower crack life cycle. It is because the crack length proposed in the simulation model is well normalized. So, Gaussian distribution function has an advantage to describe physical events.

By comparing the deterministic-Gaussian Monte Carlo combined method with a fully deterministic method for a plate with 14 holes, a gear tooth and a bracket, the random behavior of fatigue failure is revealed in this study. The results show that the random behavior can only be demonstrated by the deterministic-Gaussian Monte Carlo combined method.

of the hole. Double notches are made at the left and right sides of the bracket hole. From the DBEM-Monte Carlo results presented in Table 4, crack propagation consists of a few iterations. The analysis is run until 7th iteration to get the maximum cycles of failure. Figs. 14–16 show the fatigue crack propagation at the right side from the random process.

Fig. 17 illustrates the failure mode by a fully deterministic approach. Notch 1 fails when fatigue life reaches 11.5670×10^4 cycles. Crack starts to propagate at 8.2669×10^4 cycles and the

References

- [1] Ditlevsen O, Olsen R. Statistical analysis of the Virkler data on fatigue crack growth. *Engineering Fracture Mechanics* 1986;25(2):177–95.
- [2] Yang JN, Manning SD, Rudd JL, Bader RM. Investigation of mechanistic-based equivalent initial flaw size approach, in: ICAF 95, International Committee on Aeronautical Fatigue—18th symposium, Melbourne, Australia, 1995.
- [3] Cherniavsky AO. Probabilistic approach to calculation of kinetics of crack meshes. *Dynamics, Strength & Wear-resistance of Machines* 1997;3:91–5.
- [4] Cadini FE, Zio, Avram D. Model-based Monte Carlo state estimation for condition-based component replacement. *Reliability Engineering & System Safety* 2009;94(3):752–8.
- [5] Tong YC. Review on aircraft structural risk and reliability analysis. Airframes and Engines Division, Aeronautical and Maritime Research Laboratory, 2001.
- [6] Kebir H, Roelandt JM, Gaudin J. Monte-Carlo simulations of life expectancy using the dual boundary element method. *Engineering Fracture Mechanics* 2001;68:1371–84.
- [7] Paris PC, Erdogan F. Critical analysis of propagation laws. *Journal of Basic Engineering* 1963;85:528–34.
- [8] Forman RG, Shivakumar V, Newman JC. Fatigue crack growth computer program “NASA/FLAGRO”, 2nd ed. Texas: National Aeronautics and Space Administration Press; 1993.
- [9] Dharani LR. Fatigue crack growth, Department of Mechanical and Aerospace Engineering and Engineering Mechanics, University of Missouri-Rolla, 2001.
- [10] Portela A, Aliabadi MH, Rooke DP. Dual boundary element incremental analysis of crack propagation. *Computers and Structures* 1993;46:237–47.
- [11] Moës N, Gravouil A, Belytschko T. A finite element method for crack growth without remeshing. *International Journal for Numerical Methods in Engineering* 1999;46(1):1371–84.
- [12] Apicella A, Citarella R, Esposito R. MSD residual strength assessment for a cracked joint. UK: Computational Mechanics BEASY Publications; 1999.