

PERATURAN DIREKTUR JENDERAL PERHUBUNGAN UDARA
NOMOR : SKEP/ 130/ VI /2009

TENTANG

**PETUNJUK PERATURAN KESELAMATAN PENERBANGAN SIPIL BAGIAN 173
(*MANUAL OF STANDARD PART 173*), STANDAR PELAKSANAAN KETENTUAN
PERANCANGAN PROSEDUR PENERBANGAN INSTRUMEN (*STANDARDS
APPLICABLE TO THE PROVISION OF INSTRUMENT FLIGHT PROCEDURE DESIGN*)**

DENGAN RAHMAT TUHAN YANG MAHA ESA

DIREKTUR JENDERAL PERHUBUNGAN UDARA,

- Menimbang :
- a. bahwa untuk menjamin keselamatan pengoperasian pesawat udara secara instrumen pada saat terbang jelajah, pendekatan, pendaratan dan lepas landas diperlukan prosedur penerbangan instrumen;
 - b. bahwa untuk melaksanakan ketentuan sebagaimana dimaksud pada huruf a, perlu diatur Petunjuk Peraturan Keselamatan Penerbangan Sipil Bagian 173 (*Manual of Standard Part 173*) tentang Standar Pelaksanaan Ketentuan Perancangan Prosedur Penerbangan Instrumen (*Standards Applicable To The Provision Of Instrument Flight Procedure Design*), dengan Peraturan Direktur Jenderal Perhubungan Udara;
- Mengingat :
1. Undang-undang Nomor 1 Tahun 2009 tentang Penerbangan (Lembaran Negara Tahun 2009 Nomor 1, Tambahan Lembaran Negara Nomor 4956);
 2. Peraturan Pemerintah Nomor 3 Tahun 2001 tentang Keamanan dan Keselamatan Penerbangan (Lembaran Negara Tahun 2001 Nomor 9, Tambahan Lembaran Negara Nomor 4075);
 3. Peraturan Presiden Nomor 9 Tahun 2005 tentang Kedudukan, Tugas, Fungsi, Kewenangan, Susunan Organisasi dan Tata Kerja Kementerian Negara Republik Indonesia sebagaimana telah diubah terakhir dengan Peraturan Presiden Nomor 94 Tahun 2006;

4. Peraturan Presiden Nomor 10 Tahun 2005 tentang Unit Organisasi dan Tugas Eselon I Kementerian Negara Republik Indonesia sebagaimana telah diubah terakhir dengan Peraturan Presiden Nomor 17 Tahun 2007;
5. Peraturan Menteri Perhubungan Nomor KM 43 Tahun 2005 tentang Organisasi dan Tata Kerja Departemen Perhubungan, sebagaimana telah diubah terakhir dengan Peraturan Menteri Perhubungan Nomor KM 20 Tahun 2008;
6. Peraturan Menteri Perhubungan Nomor KM 21 Tahun 2009 tentang Peraturan Keselamatan Penerbangan Sipil Bagian 173 (*Civil Aviation Safety Regulation Part 173*) tentang Perancangan Prosedur Penerbangan Instrument (*Instrument Flight Procedure Design*);

MEMUTUSKAN :

Menetapkan : **PERATURAN DIREKTUR JENDERAL PERHUBUNGAN UDARA TENTANG PETUNJUK PERATURAN KESELAMATAN PENERBANGAN SIPIL BAGIAN 173 (*MANUAL OF STANDARD PART 173*), STANDAR PELAKSANAAN KETENTUAN PERANCANGAN PROSEDUR PENERBANGAN INSTRUMEN (*STANDARDS APPLICABLE TO THE PROVISION OF INSTRUMENT FLIGHT PROCEDURE DESIGN*).**

Pasal 1

Memberlakukan Petunjuk Peraturan Keselamatan Penerbangan Sipil Bagian 173 (*Manual of Standard Part 173*), Standar Pelaksanaan Ketentuan Perancangan Prosedur Penerbangan Instrumen (*Standards Applicable To The Provision Of Instrument Flight Procedure Design*).

Pasal 2

Petunjuk Peraturan Keselamatan Penerbangan Sipil Bagian 173 (*Manual of Standard Part 173*) Standar Pelaksanaan Ketentuan Perancangan Prosedur Penerbangan Instrumen (*Standards Applicable To The Provision Of Instrument Flight Procedure Design*), sebagaimana tercantum dalam Lampiran Peraturan ini.

Pasal 3

Direktur Navigasi Penerbangan mengawasi pelaksanaan Peraturan ini.

Pasal 4

Peraturan ini mulai berlaku pada tanggal ditetapkan.

Ditetapkan di : Jakarta
Pada tanggal : 11 Juni 2009

DIREKTUR JENDERAL PERHUBUNGAN UDARA

ttd

HERRY BAKTI

SALINAN Peraturan ini disampaikan kepada :

1. Menteri Perhubungan;
2. Sekretaris Jenderal Departemen Perhubungan;
3. Inspektur Jenderal Departemen Perhubungan;
4. Sekretaris Direktorat Jenderal Perhubungan Udara;
5. Para Direktur di lingkungan Ditjen Perhubungan Udara.

Salinan sesuai dengan aslinya

**Kepala Bagian Hukum
Setditjen Hubud**

RUDI RICHARDO

Pasal 4

Peraturan ini mulai berlaku pada tanggal ditetapkan.

Ditetapkan di : Jakarta
Pada tanggal : 11 Juni 2009

DIREKTUR JENDERAL PERHUBUNGAN UDARA



HERRY BAKTI

SALINAN Peraturan ini disampaikan kepada :

1. Menteri Perhubungan;
2. Sekretaris Jenderal Departemen Perhubungan;
3. Inspektur Jenderal Departemen Perhubungan;
4. Sekretaris Direktorat Jenderal Perhubungan Udara;
5. Para Direktur di lingkungan Ditjen Perhubungan Udara.

Pasal 4

Peraturan ini mulai berlaku pada tanggal ditetapkan.

Ditetapkan di : Jakarta
Pada tanggal : 11 Juni 2009

1 2
DIREKTUR JENDERAL PERHUBUNGAN UDARA



HERRY BAKTI

SALINAN Peraturan ini disampaikan kepada :

1. Menteri Perhubungan;
2. Sekretaris Jenderal Departemen Perhubungan;
3. Inspektur Jenderal Departemen Perhubungan;
4. Sekretaris Direktorat Jenderal Perhubungan Udara;
5. Para Direktur di lingkungan Ditjen Perhubungan Udara.

Lampiran Peraturan Direktur Jenderal
Perhubungan Udara
Nomor : SKEP/130/VI/2009
Tanggal : 11 JUNI 2009

MANUAL OF STANDARD (MOS)

PART 173

Standards Applicable to the Provision of Instrument Flight Procedure Design

**DIRECTORATE GENERAL OF CIVIL AVIATION
MINISTRY OF TRANSPORTATION**

**Manual of Standards Part 173
Standards Applicable to The Provision of
Instrument Flight Procedure Design**

TABLE OF CONTENTS

	Page
LIST OF EFFECTIVE PAGES	v
AMENDMENT RECORD.....	vi
CHAPTER 1: INTRODUCTION.....	1
Section 1.1: General	1
1.1.1 Authority for this Part and DGCA's Commitment to ICAO.....	1
1.1.2 Differences between PANS-OPS Standards and those in the MOS	1
1.1.3 Document Set	1
1.1.4 MOS Documentation Change-Management	2
1.1.5 Related Documents	3
CHAPTER 2: ORGANIZATION	4
Section 2.1: Operations Manual	4
2.1.1 Standards	4
2.1.2 Authorized Designers	5
CHAPTER 3: DESIGN PERSONNEL	6
Section 3.1: Certified Designers	6
3.1.1 Grades of Instrument Flight Procedure Designer	6
3.1.2 Chief Designer	6
3.1.3 Qualified Designer	6
3.1.4 Unqualified Persons	7
3.1.5 Supervisors	7
3.1.6 Minimum Experience	7
3.1.7 Recency	7
Section 3.2: Authorized Designers	7
3.2.1 Qualifications and Experience	7
Section 3.3: Approved Instrument Flight Procedure Design Courses...	8
3.3.1 Approval of Courses	8
Section 3.4: Administration	9
3.4.1 Staff Records	9
3.4.2 Approvals	9
CHAPTER 4: DOCUMENTATION AND REFERENCE MATERIAL.....	10
Section 4.1: General	10
4.1.1 Reference Material	10

4.1.2	Document and Record Control System	10
4.1.3	Records	10
CHAPTER 5: SAFETY MANAGEMENT SYSTEM		12
Section 5.1: General		12
5.1.1	Requirement	12
5.1.2	Safety Management System—Standards	12
CHAPTER 6: PROCEDURE DESIGN ADMINISTRATION		13
Section 6.1: General		13
6.1.1	Classification of Procedures	13
6.1.2	Validation	13
6.1.3	Publication	13
6.1.4	Maintenance	14
6.1.5	Obstacle Clearance Advice to Aerodrome Operators	14
Section 6.2: Design Authorizations		15
6.2.1	General	15
6.2.2	Content	15
CHAPTER 7: FLIGHT VALIDATION		16
Section 7.1: General		16
7.1.1	Overview	16
7.1.2	Maps and Charts.....	16
7.1.3	Weather	16
7.1.4	Responsibilities	17
7.1.5	Aircraft	17
7.1.6	Crew	17
7.1.7	Conduct of Operations	17
7.1.8	Environment.....	18
7.1.9	Validation of the Procedure.....	18
7.1.10	25 and 10 NM Minimum Sector Altitude	18
7.1.11	Terminal Arrival Altitude (TAA)	19
7.1.12	DME/GPS Arrival Procedures	19
7.1.13	Circling Area	19
7.1.14	Final and Intermediate Segments	19
7.1.15	Missed Approach Segment.....	20
7.1.16	Linking the Final and Missed Approach Segments	21
7.1.17	Holding and Initial Segments	22
7.1.18	'Flyability' Check	22
7.1.19	Windsocks	22
7.1.20	Flight Safety	22
7.1.21	Traffic.....	22
7.1.22	Environmental Issues	23
7.1.23	Reporting	23
7.1.24	Pilots	23
Section 7.2: Sample Flight Validation Report		24
CHAPTER 8: DESIGN STANDARDS.....		26

Section 8.1: General	26
8.1.1 Procedure Design	26
8.1.2 Procedure Identification	28
8.1.3 Straight-in Non-Precision Approach Procedures	28
8.1.4 Visual Segment Limitations	30
8.1.5 OCA and Descent Limits	31
8.1.6 Visibility	32
8.1.7 State Minima	33
8.1.8 Aerodrome Operating Minima (AOM)	34
8.1.9 General Alternate Minima	34
8.1.10 Special Alternate Minima	34
8.1.11 International IFR Operations Outside Indonesia	36
8.1.12 Indonesian Differences to ICAO PANS-OPS Vol II	37
8.1.13 Table of Operationally Equivalent Values	38
Section 8.2: Lowest Safe Altitudes	39
8.2.1 Lowest Safe Altitudes	39
8.2.2 Effective Areas	39
8.2.3 Charts	40
8.2.4 Altitude Tolerance	41
8.2.5 Navigation Tolerance Area Construction—Examples	42
Section 8.3: DME/GPS Arrivals	47
8.3.1 Introduction to DME/GPS Arrival Procedures	47
8.3.2 DME/GPS Arrival Procedure Design	48
8.3.3 Obstacle Clearance	50
8.3.4 DME/GPS Steps	50
8.3.5 Minimum Altitudes	51
8.3.6 Missed Approach	51
8.3.7 Method of Production	51
Section 8.4: Standard Terminal Arrival Routes (STARs)	53
8.4.1 STAR Standards	53
Section 8.5: Standard Instrument Departures (SIDs)	53
8.5.1 SID Standards	53
Section 8.6: Helicopter Off-shore Procedures—Airborne Radar	53
8.6.1 Application	53
8.6.2 Administration	53
8.6.3 Limitations	54
8.6.4 Airborne Radar Equipment/Ground Radar Equipment.....	54
8.6.5 Flight Crew Techniques	55
8.6.6 Types of Procedures.....	56
8.6.7 Procedure Design Principles	56
8.6.8 Procedure Design Tolerances	56
8.6.9 Procedure Area.....	58
8.6.10 Flight Crew Operating Tolerances	58
8.6.11 Minima Determination	58

8.6.12	Values.....	58
8.6.13	Minimum Altitudes	58
8.6.14	Visibility.....	58
8.6.15	Missed Approach Point (MAPT).....	58
8.6.16	Obstacle Avoidance Determination.....	59
8.6.17	Helicopter IALs	60
Section 8.7: Helicopter Off-shore Procedures - NDB		63
8.7.1	Application	63
8.7.2	Administration	63
8.7.3	Limitations Applying to Procedures Issued under this Standard.....	63
8.7.4	Minima Determination	64
8.7.5	Assumptions Underlying these Procedures	64
8.7.6	Collision Avoidance Determination	64
8.7.7	NDB	66
Section 8.8: Helicopter Procedures - GPS/NPAs		67
8.8.1	Application	67
8.8.2	Administration	67
8.8.3	Procedure Overview	67
8.8.4	Visual Approach Area—Helicopter.....	68
8.8.5	VAA-H Dimensions	68
8.8.6	Obstacle Clearance	69
8.8.7	Missed Approach	69
8.8.8	Calculation of MDA	70
Section 8.9: Publishing		70
8.9.1	Electronic Format.....	70
8.9.2	Text Format	71
8.9.3	Drafting Conventions	74
CHAPTER 9: COMPUTATIONS		83
Section 9.1: Visibility		83
9.1.1	Runway Approaches.....	83
9.1.2	Circling Visibility	83
REVISION HISTORY		85

LIST OF EFFECTIVE PAGES

Part	No. of Pages	Version	Date of Issue
Cover and verso			
Table of Contents			
List of Effective Pages			
Amendment Record			
Foreword			
Chapter 1. Introduction			
Chapter 2. Organization			
Chapter 3. Design Personnel			
Chapter 4. Documentation and Reference Material			
Chapter 5. Safety Management System			
Chapter 6. Procedure Design Administration			
Chapter 7. Flight Validation			
Chapter 8. Design Standards			
Chapter 9. Computations			
Revision History			

RECORD

The amendments listed below have been incorporated into this copy of Manual of Standards Part 173—Standards Applicable to the Provision of Instrument Flight Procedure Design.

Version Number	Chapter Affected	Pages Replaced	Signature	Date

CHAPTER 1: INTRODUCTION

SECTION 1.1: GENERAL

1.1.1 Authority for this Part and DGCA's Commitment to ICAO

1.1.1.1 The Civil Aviation Safety Regulations Part 173 – Instrument Flight Procedure Design establishes the standards pertaining to the design of Instrument Flight Procedures.

1.1.1.2 The design standards are contained in:

- a. International Civil Aviation Organization (ICAO) Publication Doc. 8168-OPS/611 Volumes I and II, hereafter referred to as *PANS-OPS*; and
- b. those included in this Manual of Standards (MOS), which are additional design standards not included in *PANS-OPS*, differences adopted by Australia, and new or developing standards.

1.1.2 Differences between PANS-OPS Standards and those in the MOS

1.1.2.1 Notwithstanding the above, where there is a difference between a standard prescribed in ICAO documents and the MOS, the MOS standard shall prevail.

1.1.3 Document Set

1.1.3.1 The document hierarchy consists of:

- a. relevant Civil Aviation Safety Regulations (CASRs);
- b. the Manual of Standards (MOS); and
- c. Advisory Circulars (ACs).

1.1.3.2 The regulatory documents establish, for service providers, a comprehensive description of system requirements and the means of meeting them.

1.1.3.3 **CASRs** establish the regulatory framework (*Regulations*) within which all service providers must operate.

1.1.3.4 The **MOS** comprises specifications (*Standards*) prescribed by DGCA, of uniform application, determined to be necessary for the safety of air navigation. In those parts of the MOS where it is necessary to establish the context of standards to assist in their comprehension, the sense of parent regulations has been reiterated.

- 1.1.3.5 Readers should understand that in the circumstance of any perceived disparity of meaning between MOS and CASRs, primacy of intent rests with the regulations.
- 1.1.3.6 Service providers must document internal practices (*Rules*) in their own operational manuals, to ensure the maintenance of and compliance with standards.
- 1.1.3.7 **ACs** are intended to provide recommendations and guidance to illustrate a means, but are not necessarily the only means of complying with the Regulations. ACs may explain certain regulatory requirements by providing interpretive and explanatory material. It is expected that service providers will document internal actions in their own operational manuals, to put into effect those, or similarly adequate, practices.
- 1.1.4 MOS Documentation Change Management**
- 1.1.4.1 Responsibility for the approval of the publication and amendment of the MOS resides with Civil Aviation Safety Authority (DGCA) and the operator.
- 1.1.4.2 This document is issued and amended under the authority of Directorate General of Civil Aviation.
- 1.1.4.3 Requests for **any change** to the content of this MOS may be initiated by:
- a. technical specialist areas within DGCA;
 - b. instrument approach procedure designers;
 - c. ATS service providers;
 - d. pilots and ATC staff;
 - e. other aviation industry service providers.
- 1.1.4.4 The need to **change standards** in the MOS may be generated by a number of causes. These may be to:
- a. ensure safety;
 - b. ensure standardization;
 - c. respond to changed DGCA standards;
 - d. respond to ICAO prescription;
 - e. accommodate new initiatives or technologies.

1.1.5 Related Documents

1.1.5.1

These standards should be read in conjunction with:

- a. ICAO Procedures for Air Navigation — Air Operations, Volume II - Construction of Visual and Instrument Flight Procedures, DOC. 8168-OPS/611 Volume II;
- b. ICAO Template Manual for Holding, Reversal and Racetrack Procedures, DOC 9371-AN/912/2;
- c. ICAO Collision Risk Manual (CRM) Doc 9274 - AN/904;
- d. ICAO Instrument Flight Procedures Construction Manual.

CHAPTER 2: ORGANIZATION

SECTION 2.1: OPERATIONS MANUAL

2.1.1 Standards

- 2.1.1.1 A certified designer must prepare an Operations Manual in accordance with the following requirements:
- a. a table of contents based on the items in the manual, indicating the page number on which each item begins;
 - b. a description of the designer's organizational structure and a statement setting out the functions that the designer performs, or proposes to perform under CASR Part 173;
 - c. a description of the chain of command established, or proposed to be established, by the designer and a statement of the duties and responsibilities of any supervisory positions within the organizational structure;
 - d. a statement showing how the designer determines the number of operational staff required including the number of operational supervisory staff;
 - e. a list of the design services that the designer provides, or proposes to provide;
 - f. a statement, for each design service, that identifies the location from where the service is provided, or proposed to be provided;
 - g. a statement of the responsibilities and functions for each position;
 - h. a description of the arrangements made or proposed to be made by the designer to ensure that it has, and will continue to receive, the information necessary for providing the service;
 - i. a description of the arrangements made or proposed to be made by the designer to ensure that it has, and will continue to be able to provide, information in connection with its design services to another person whose functions reasonably require that information;
 - j. a description of the designer's record keeping system;
 - k. a statement detailing any agreement entered into by the designer in relation to the provision of a design service provided by another party;
 - l. a copy of the document that sets out the designer's safety management system;
 - m. a description of the processes and documentation used to present to staff the relevant standards, rules and procedures contained in ICAO Doc 8168 and this MOS, and any of the designer's site-specific instructions for the provision of design services;
 - n. a description of the processes and documentation used to provide operational instructions to staff;

- o. a description of the procedures to be followed to ensure all operational staff are familiar with any operational changes that have been issued since they last performed operational duties;
- p. a description of the designer's training and checking program;
- q. a description of the procedures to be used in commissioning new facilities, equipment and services;
- r. a description of the procedures to be used to ensure that designs are completed in accordance with the drafting conventions contained in this MOS;
- s. a description of the format(s) that will be used for the issue of completed designs for publication;
- t. a description of the procedures to be used to ensure that all equipment, including software is operated in accordance with the manufacturer's operating instructions and manuals;
- u. the safety management system of the certified designer;
- v. a description of the procedures to be used to conduct environmental assessments; and
- w. the procedures to be followed for revising the operations manual.

2.1.2 Authorized Designers

- 2.1.2.1 An Authorized designer must include in an Operations Manual the procedures and practices which are followed in the application of its Authorization under CASR Part 173.
- 2.1.2.2 The Operations Manual must include those items listed in paragraph 2.1.1.1 that are relevant.

CHAPTER 3: DESIGN PERSONNEL

SECTION 3.1: CERTIFIED DESIGNERS

3.1.1 Grades of Instrument Flight Procedure Designer

- 3.1.1.1 The grades established under CASR Part 173 for certified design organizations are:
- a. Chief Designer;
 - b. Qualified Designer;
 - c. Unqualified Designer.

3.1.2 Chief Designer

- 3.1.2.1 The minimum standard for the qualifications and experience of a Chief Designer is:
- a. the qualification and experience requirements of a Qualified Designer;
 - b. appropriate experience in the design of the type of procedures to be designed under an Instrument Flight Procedure Design Certificate; and
 - c. satisfactory completion of an advanced course in PANS-OPS procedure design.

Note:

For guidance on the experience requirements under b. and c. above, see AC 173-02.

- 3.1.2.2 The minimum standard of recent experience for appointment as a Chief Designer is:
- a. relevant design experience within the previous one year; or
 - b. satisfactory completion of an approved PANS-OPS procedures design course or an advanced course on PANS-OPS procedure design within the previous two years.

3.1.3 Qualified Designer

- 3.1.3.1 The minimum standard for the qualifications and experience of a Qualified Designer is:
- a. satisfactory completion of an approved PANS-OPS procedures design course; and
 - b. satisfactory completion of a course of in-service training in procedures design as detailed in the designer's operations manual; and
 - c. required minimum experience in accordance with paragraph 3.1.6; and

- d. a written approval by the Chief Designer as specified in Section 3.4.

3.1.4 Unqualified Persons

- 3.1.4.1 Personnel who are not qualified under paragraph 3.1.1 must not:
 - a. design a procedure for which a Certificate of Approval is required under CASR Part 173, except under direct supervision; or
 - b. verify (check) a procedure for which a Certificate of Approval is required under CASR Part 173.

3.1.4.2 Direct supervision means supervision by a qualified designer who is engaged on a full-time basis in the same premises.

3.1.5 Supervisors

- 3.1.5.1 The minimum standard for the qualifications and experience of persons responsible for the supervision of other design staff is:
 - a. Qualified Designer; and
 - b. substantial experience in the design of instrument flight procedures.

3.1.6 Minimum Experience

- 3.1.6.1 Minimum design experience is required for each type of procedure to be designed.
- 3.1.6.2 The minimum experience required is three designs, checked and approved by a Chief Designer, and completed within any six consecutive months.

3.1.7 Recency

- 3.1.7.1 A person must not design (except under direct supervision) or verify a procedure, unless he/she has designed, checked or been directly involved in the detailed review of a procedure of the same type within the previous year.

SECTION 3.2: AUTHORIZED DESIGNERS

3.2.1 Qualifications and Experience

- 3.2.1.1 The minimum standard for the qualifications and experience of persons holding a Procedure Design Authorization or employed by the holder of a Procedure Design Authorization to review and/or amend procedures in accordance with CASR Part 173 Subpart C is:
 - a. satisfactory completion of an approved PANS-OPS course; and

- b. design of three procedures of each type of procedure to be reviewed or amended, completed within any six consecutive months. The Authorized designer shall include in the company operations manual, training and checking procedures to ensure that design personnel meet the minimum standards.

3.2.1.2 The minimum standard for the qualifications and experience of persons Authorized to design off-shore helicopter procedures in accordance with CASR Part 173 Subpart C is:

- a. extensive experience as pilot-in-command of IFR operations to offshore structures; and
- b. a demonstrated knowledge of and experience in the design of procedures in accordance with Section 8.6 and/or Section 8.7 as applicable.

3.2.1.3 DGCA must also consider the amount of additional practical experience that may be appropriate to an Authorization and the level of supervision that must be provided.

SECTION 3.3: APPROVED INSTRUMENT FLIGHT PROCEDURE DESIGN COURSES

3.3.1 Approval of Courses

3.3.1.1 In determining whether a course will be considered as an approved course, the following will be taken into consideration:

- a. an appropriate syllabus;
- b. adequate duration;
- c. appropriately qualified and experienced course lecturer(s);
- d. the provider/institution.

3.3.1.2 Approval of a course may require on-site inspection and observation of the conduct of the course.

3.3.1.3 Where assessment required in paragraph 3.3.1.1 is not possible due to the lapse in time since the course was provided, DGCA may consider a course to be approved if:

- a. sufficient evidence exists that the course was completed satisfactorily; and
- b. the course could reasonably have been expected to meet the minimum requirements of an approved course applicable at the time that it was completed; and
- c. the applicant can provide evidence of additional training or practical experience which enable the applicant to satisfy the syllabus requirements of an approved course.

SECTION 3.4: ADMINISTRATION

3.4.1 Staff Records

- 3.4.1.1 The Chief Designer shall maintain a register of:
- a. personnel qualifications and courses attended;
 - b. staff training;
 - c. proficiency checks conducted;
 - d. staff approvals;
 - e. staff recency.

3.4.2 Approvals

- 3.4.2.1 The Chief Designer shall provide each staff member engaged in instrument flight procedure design as a Qualified Designer with a written statement specifying:
- a. that the person is a Qualified Designer; and
 - b. the types of procedure that the person is approved to design; and
 - c. any limitations or supervision requirements that apply; and
 - d. any approval to supervise other design staff.

CHAPTER 4: DOCUMENTATION AND REFERENCE MATERIAL

SECTION 4.1: GENERAL

4.1.1 Reference Material

4.1.1.1 The following documents are required where applicable to the type of Instrument Flight Procedure designed:

- a. ICAO Procedures for Air Navigation — Air Operations, Volume II - Construction of Visual and Instrument Flight Procedures, DOC 8168-OPS/611 Volume II;
- b. ICAO Template Manual for Holding, Reversal and Racetrack Procedures, DOC 9371-AN/912/2;
- c. ICAO Collision Risk Manual (CRM);
- d. ICAO Instrument Flight Procedures Construction Manual;
- e. DGCA Manual of Standards (MOS) Part 173.

4.1.2 Document and Record Control System

4.1.2.1 Document and data control processes are those that control the Authorization, publication, distribution, and amendment of all documentation issued or required by certified designers and Authorized designers.

4.1.2.2 These processes must ensure that:

- a. documents are Authorized by the Chief Designer or a designated person;
- b. the currency of documentation can be readily determined;
- c. documents are available at locations where needed by staff;
- d. only current versions of documents are available;
- e. A master copy of all documentation is securely held; and
- f. all documents that are related to and referenced in the Operations Manual are indexed in the Operations Manual.

4.1.3 Records

4.1.3.1 A certified or Authorized designer must maintain the following records:

- a. all certificates, correspondence, data, calculations, worksheets, drawings, charts and other information pertaining to the design of a procedure;
- b. staff records (see paragraph 3.4.1). 4.1.3.2 Records must be made available for audit by DGCA.

4.1.3.3 Records relating to procedure designs must be retained for the period that a procedure is available for use and for a period of two years after a procedure ceases to be available or is withdrawn.

4.1.3.4 Staff records must be retained during the time that staff are employed.

CHAPTER 5: SAFETY MANAGEMENT SYSTEM

SECTION 5.1: GENERAL

5.1.1 Requirement

5.1.1.1 A certified designer must establish and maintain a Safety Management System (SMS) in accordance with the following standards.

5.1.2 Safety Management System—Standards

5.1.2.1 A Safety Management System must define the policies, processes, and practices for managing the safety of all procedure design work.

5.1.2.2 A Safety Management System that meets the following criteria is to be issued under the authority of the Chief Designer.

- 5.1.2.3 The Safety Management System must:
- a. be a comprehensive and valid statement of the safety situation that applies in actual operations;
 - b. define the organization's safety objectives;
 - c. present the safety situation in respect to compliance with all relevant DGCA, ICAO, internal, and other safety related standards;
 - d. define the safety accountabilities of all personnel;
 - e. be kept under review for effectiveness by all personnel;
 - f. include arrangements to encourage staff to identify safety hazards or concerns and suggest methods for enhancement of safety;
 - g. establish procedures for the communication and processing of safety concerns within the organization;
 - h. define the interface arrangements between internal groups of the organization;
 - i. be available to, and complied with, by all personnel of the organization;
 - j. contain a safety hazard/risk analysis and risk control/mitigation assessment in accordance with an established methodology endorsed by DGCA;
 - k. include a quality management system based on those elements of ICAO relevant to instrument flight procedure design;
 - l. be documented in a manner that is readily available to all staff.

CHAPTER 6: PROCEDURE DESIGN ADMINISTRATION

SECTION 6.1: GENERAL

6.1.1 Classification of Procedures

- 6.1.1.1 Terminal Instrument Flight Procedures are classified as one of the following types:
- a. Non-precision Approach (Ground-based);
 - b. Non-precision Approach (RNAV);
 - c. Precision Approach (Ground-based);
 - d. Precision Approach (RNAV);
 - e. Approach with Vertical Guidance (APV);
 - f. Departure;
 - g. Helicopter (Off-shore)—Airborne Radar;
 - h. Helicopter (Off-shore)—Non-directional Beacons (NDB).

6.1.2 Validation

6.1.2.1 All designs other than those at g. and h. above are to be validated in accordance with the standards in Chapter 7.

6.1.2.2 On completion of a design, a certified designer must apply to DGCA for flight validation. The address for the application is:

**DGCA, Directorate of Air Navigation
Karya Building 23rd Floor
Medan Merdeka Barat No. 8
Jakarta 10110**

6.1.2.3 The application is to include a completed draft copy of the design procedure prepared for publication in accordance with Chapter 9 of this Manual.

6.1.2.4 DGCA shall arrange for a DGCA officer who is a qualified validation pilot to conduct the flight validation.

6.1.2.5 The certified designer shall provide an aircraft of a type approved by the DGCA officer conducting the flight validation.

6.1.2.6 The certified designer shall provide a qualified designer to be part of the validation crew.

6.1.3 Publication

6.1.3.1 **Public Procedures.** For a procedure which is to be published in the AIP, the certified designer shall forward to the AIS:

- a. A Certificate of Design signed by the Chief Designer stating that the design has been completed in accordance with CASR Part 173, and,
- b. A copy of the design in the format specified in Chapter 9 of this MOS.

6.1.3.2 Other procedures. For a procedure which is not to be published in the AIP, and is not a procedure published by a foreign State that has been amended by an Authorized designer, the certified designer or Authorized designer shall forward to:

DGCA, Directorate of Air Navigation
Karya Building 23rd Floor
Medan Merdeka Barat No. 8
Jakarta 10110:

- a. a copy of the design in the format specified in this MOS; and
- b. for other than Off-shore Specialised Helicopter Designs, a Certificate of Design signed by the Chief Designer stating that the design has been completed in accordance with CASR Part 173.

6.1.4 Maintenance

6.1.4.1 Maintenance of an Instrument Flight Procedure includes:

- a. general text and data amendments;
- b. redesign to conform with changes to design standards;
- c. provision of advice regarding obstructions in the vicinity of the aerodrome or procedure;
- d. redesign or amendment required as a result of changes to critical obstacles;
- e. changes as directed by DGCA; but excludes the periodic flight revalidation of procedures.

6.1.4.2 At intervals not exceeding three years, DGCA shall conduct a flight revalidation of a procedure. On completion of a flight re-validation, DGCA will advise the certified designer of any changes required.

6.1.5 Obstacle Clearance Advice to Aerodrome Operators

6.1.5.1 Prior to the effective publication date of a procedure, the certified designer must forward to the aerodrome operator for which a procedure has been designed, diagrams and obstacle data sufficient to enable the aerodrome operator to fulfil obligations to report and monitor obstacles in the vicinity of an aerodrome as required under CASR Part 139.

SECTION 6.2: DESIGN AUTHORIZATIONS

6.2.1 General

6.2.1.1 This section details the standards that must be applied to the issue of a procedure design Authorization in accordance with CASR Part 173 Subpart C.

6.2.1.2 Authorizations are required for persons engaged in:

- a. the review and/or amendment of terminal instrument flight procedures at aerodromes outside Australia in order to apply Australian standards to procedures promulgated by foreign States; and
- b. the design of helicopter off-shore procedures in accordance with Section 8.6 (Helicopter Off-shore Procedures—Airborne Radar) and Section 8.7 (Helicopter Off-shore Procedures—NDB).

6.2.2 Content

6.2.2.1 A Design Authorization shall contain the following:

- a. the names of persons Authorized; and
- b. details of the work that those persons are Authorized under CASR Part 173 to perform; and
- c. the standards or design criteria to be used; and
- d. any limitation or conditions that apply to the Authorization; and
- e. the procedures to be followed in the application of the Authorization and the incorporation of those procedures in company operations manuals or other appropriate documents.

CHAPTER 7: FLIGHT VALIDATION

SECTION 7.1: GENERAL

7.1.1 Overview

- 7.1.1.1 Flight validation is required for:
- instrument approach procedures;
 - revised instrument approach procedures where the final course has been re aligned by 3° or more.
- 7.1.1.2 Validation of an instrument flight procedure comprises:
- a review of the draft procedures from an operational perspective conducted by the validation pilot; and
 - a validation flight check.
- 7.1.1.3 The process of instrument approach procedure design focuses on those controlling obstacles that affect the procedure. This focus is facilitated through the use of various obstacle and terrain databases. The purpose of flight validation is to verify database information, to check all obstacles (including the identification of any unforeseen obstacles) that affect the safety of the procedure, and to assess the 'flyability' of the procedure.

7.1.2 Maps and Charts

- 7.1.2.1 Validation flights must carry maps and charts that meet the following requirements:
- An appropriate topographical map of at least 1:250,000 scale or larger scale. (A scale of 1:100,000 may be necessary in areas of precipitous terrain and when checking circling, final and missed approach segments.) The map must be marked by the procedure designer with:
- final segment splay/s;
 - missed approach segment splay/s;
 - circling area for the appropriate categories or category groups; and
 - controlling obstacles for each segment, MSA and holding pattern.

7.1.3 Weather

- 7.1.3.1 Validation flights must be undertaken in daylight hours and in VMC. The ceiling should be above the initial approach altitude (preferably above the 25 NM MSA).

7.1.4 Responsibilities

7.1.4.1 The Chief Designer is responsible for the organization of flight validation activities.

7.1.4.2 The procedure design flight validation crew member is responsible for the planning of validation flights.

7.1.5 Aircraft

7.1.5.1 The standard for the type of aircraft to be used for flight validation of a design is an aircraft that has performance capabilities appropriate to the type and design of the procedure.

7.1.5.2 The aircraft must be of a configuration that permits good visibility and adequate cabin dimensions permitting maps and other documents to be readily referred to in flight.

7.1.5.3 The type of aircraft is to be approved by the DGCA validation pilot.

7.1.6 Crew

7.1.6.1 The minimum crew is a pilot and a procedure designer.

7.1.6.2 Only persons involved in the validation procedure are to be carried in the aircraft.

7.1.7 Conduct of Operations

7.1.7.1 Judgment must be applied when planning the validation flight to minimize the time spent on task. Efficiently linked segments and avoiding those areas where obstacles will have no affect on the procedure will help to achieve this objective.

7.1.7.2 Crew responsibilities:

- a. the pilot must fly the aircraft;
- b. the procedure designer must:
 - (1) visually navigate the aircraft; and
 - (2) direct the pilot by providing tracks and altitudes to fly; and
 - (3) note any differences to the pre-determined list of obstacles;
- c. both crew members are responsible for lookout;
- d. when flying the segments of the procedure, the aircraft should be configured to emulate the highest category aircraft for which the procedures are planned—this will be particularly important when the length of a particular segment is short;
- e. when checking individual obstacles, the highest practical speed, commensurate with fuel reserves should be used;

- f. during the validation process, gear should be up and any lights that increase the visibility of the aircraft should be turned on.

7.1.8 Environment

- 7.1.8.1 Prior to conducting validation of a procedure in a populated or environmentally sensitive area, the procedure designer should:
 - a. discuss with the validation pilot any options for reducing the environmental impact of the flight.
 - b. as appropriate, advise the aerodrome operator, ATC, local DGCA office and any other affected persons, of the details of the proposed operation, including advice that low-level flying will be required.
 - c. advise the DGCA Public Relations office in sufficient time to permit a press release to be issued.

7.1.9 Validation of the Procedure

- 7.1.9.1 The actual sequence of checks is not mandated in this document, as each situation will suggest the most economical way of arranging the elements of the task.
- 7.1.9.2 The specified altitude(s) for the validation of an instrument approach segment is/are equal to the published segment minimum altitude(s) minus the Minimum Obstacle Clearance (MOC) applicable to the segment.
- 7.1.9.3 Each controlling obstacle and/or procedure segment must be checked at a specified altitude(s) to validate the obstacle data used and to determine whether there are any unforeseen obstacles extending above the specified altitude. Such a case would indicate that the unforeseen obstacle is higher than the controlling obstacle and that it may affect the procedure. If such an unforeseen obstacle is observed, its location and observed height AMSL must be recorded for subsequent detailed analysis by the procedure designer.

7.1.10 25 and 10 NM Minimum Sector Altitude

- 7.1.10.1 Each 25 NM sector, or the 25 NM circle, and the 10 NM circle must be checked at their specified altitudes. 25 NM and 10 NM MSAs include obstacles out to 30 NM and 15 NM respectively from the navigation aid or ARP upon which the MSA is based. Checks must include the controlling obstacle in addition to other obviously high terrain or obstacles. Where the sector/circle does not exhibit greatly differing terrain elevations, judgment may be exercised regarding the tracks flown to provide a full coverage of the area.

7.1.11 Terminal Arrival Altitude (TAA)

- 7.1.11.1 Each Terminal Arrival Altitude (TAA) sector must be checked at its specified altitude. TAAs include obstacles out to 30 NM from the initial approach fix upon which the TAA is based. Checks must include the controlling obstacle in addition to other obviously high terrain or obstacles. Where adjacent TAAs do not have greatly differing terrain elevations, judgments may be exercised regarding the tracks flown to provide a full coverage of the area.

Note:

This paragraph is included in anticipation of Terminal Arrival Altitudes being included in the next amendment to PANS-OPS.

7.1.12 DME/GPS Arrival Procedures

- 7.1.12.1 Controlling obstacles will be determined by the procedure designer for each segment within each sector of the arrival procedure. These obstacles must be checked at the specified altitude. Additionally, each step in the final and intermediate segments must be flown at the OIS altitude. Each step must be flown around the radius of the step plus 1 NM, between the lateral limits of the sector splay. The controlling obstacles for these steps can be checked during the process of flying the steps.

7.1.13 Circling Area

- 7.1.13.1 The circling area must be checked by flying around the lateral limit of the circling area for the lowest supported aircraft category or group (usually CAT A/B) at the specified altitude for that category and looking in towards the airfield. In this manner, both the controlling obstacle and any unforeseen obstacles will be seen in the one action.
- 7.1.13.2 The same procedure is then used to check obstacles in the circling area for the next highest supported aircraft category or group (CAT C/D). By conducting the inner check first, obstacles that may affect all categories can be readily identified.
- 7.1.13.3 Circling area checks are not conducted in those areas designated 'No Circling'.

7.1.14 Final and Intermediate Segments

- 7.1.14.1 The final and, where implemented, the intermediate segment, must be checked as follows:

- a. fly from overhead the MAPT at the specified altitude for the final segment, at 90° to the final track, to the limit of the splay;
- b. turn to fly away from the airfield along the lateral edge of the splay at the final specified altitude to abeam the step down fix (if implemented) or abeam the FAF:
 - (1) abeam the step down fix, climb to the specified altitude for the next section of the final segment;
 - (2) terminate abeam the FAF unless an intermediate segment is implemented, in which case continue along the lateral limit of the intermediate segment at the intermediate specified altitude until abeam the IF and terminate at that point;
 - (3) during this process look across the splay to identify the controlling obstacle and any unforeseen obstacles;
- c. conduct the same process on the opposite side of the splay, but looking in the opposite direction;
- d. if the terrain and visibility are such that an unobstructed view can be had from one side of the splay to the other, the procedure outlined above can be shortened by flying along the centre line of the splay at the appropriate specified altitude.

7.1.15 Missed Approach Segment

- 7.1.15.1 The missed approach segment must be checked in accordance with the following:
 - a. position the aircraft at the start of climb point, determined in accordance with Figure 7-1, at the specified level;
 - b. fly the aircraft along the missed approach track, climbing at a rate that equates to the missed approach design gradient, until in the final phase of the missed approach.
- 7.1.15.2 For environments with numerous obstacles, the missed approach segment should be checked by flying the missed approach splays in a similar manner to that specified for the final and intermediate segments, but climbing along the lateral edge of the splay, in accordance with the missed approach design gradient, until in the final phase of the missed approach.

7.1.15.3 The validation start of climb must be determined in accordance with Figure 7-1

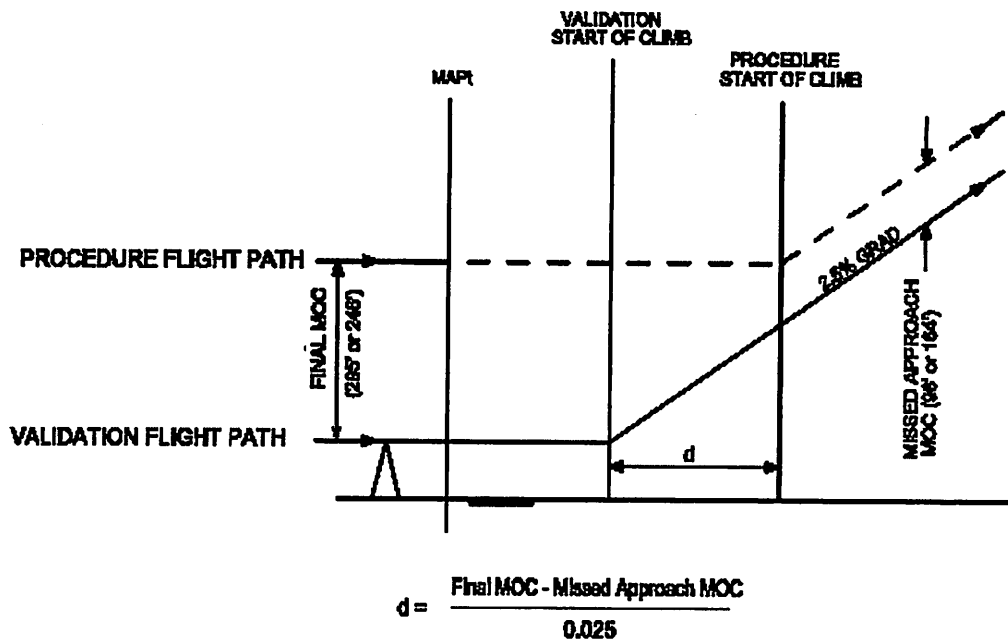

Figure 7-1: Validation start of climb

7.1.16 Linking the Final and Missed Approach Segments

7.1.16.1 Figure 7-2 shows a method for linking the checks of the final and missed approach segments.

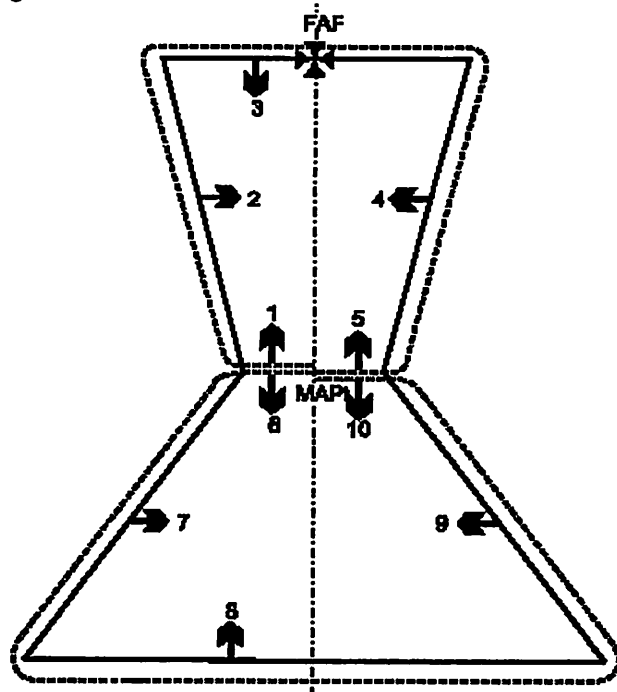

Figure 7-2: Final and missed approach segments

7.1.17 Holding and Initial Segments

7.1.17.1 The controlling obstacles for the holding and initial segments must be checked at their specified altitude and any unforeseen obstacles identified. These checks may be combined with the checks of the DME/GPS Arrival Procedure.

7.1.18 'Flyability' Check

7.1.18.1 The complete design, as proposed for publication, must be checked for operational acceptability. This check should be flown at the maximum segment speeds for the fastest category of aircraft served by the procedure. The check includes:

- a. lead radials;
- b. outbound tracks (highest use category);
- c. outbound timing (highest use category);
- d. descent gradients;
- e. bank angle for turn onto final during base turns;
- f. runway alignment and distance from runway at the minima;
- g. descent gradient from the minima for a straight-in approach;
- h. the missed approach; and
- i. acceptability of initial and intermediate segment lengths for GPS approaches.

7.1.19 Windsocks

7.1.19.1 For runway aligned approaches where a windsock is not located adjacent to the runway threshold, it must be confirmed that a windsock is visible when the aircraft is at the MDA, in accordance with CAO 92.2.

7.1.20 Flight Safety

7.1.20.1 Some of these checks will be conducted close to obstacles and in close proximity to airfields, therefore a visual-and-listening watch by all crewmembers is essential. In particular, the following points should be noted:

- a. pay particular attention to airspeed during manoeuvres with high angles of bank;
- b. be vigilant for inconspicuous towers and power transmission lines. Some towers are painted in low-contrast colours;
- c. be alert for birds, particularly near bushfire smoke and over mountainous areas or inland water bodies.

7.1.21 Traffic

7.1.21.1 Give priority to other traffic when validation requirements conflict with existing traffic patterns.

7.1.22 Environmental Issues

7.1.22.1 Try to:

- a. avoid flight over built-up areas, concentrations of animals, or other noise-sensitive areas;
- b. avoid repetitious flight over the same area or areas, and
- c. minimize high RPM noise.

7.1.23 Reporting

7.1.23.1 A flight validation report form, prepared for the applicable aerodrome, must be attached as part of the validation flight request package. The standard report format is shown in Section 7.2.

7.1.23.2 Following completion of the validation flight:

- a. the pilot must complete the validation report; and
- b. the procedure designer must process the report form and complete the follow-up action.

7.1.24 Pilots

7.1.24.1 The standard for the qualifications and experience of Pilots-in-Command of instrument flight procedure validation flights is:

- a. ATPL;
- b. current command instrument rating, endorsed for the type of procedure under validation;
- c. relevant experience in multi-engine IFR procedures;
- d. completion of a course in PANS-OPS procedures design principles;
- e. a thorough knowledge of ICAO PANS-OPS procedures design principles and methods;
- f. adequate knowledge of the design of procedures in accordance with the MOS;
- g. satisfactory completion of a flight validation course conducted by DGCA and possession of a letter of competency issued by DGCA certifying his/her competence to conduct flight validation;
- h. satisfactory completion of a course in aerodrome lighting and visual approach slope guidance systems conducted by DGCA and possession of a letter of competency issued by DGCA certifying his/her competence to conduct aerodrome lighting inspections;
- i. a low flying permit issued in accordance with CAR 157(4)b.; and
- j. completion of a procedure flight validation flight within the previous year.

7.1.24.2 Helicopter procedures are to be validated by pilots who, in addition to the above qualifications, are familiar with helicopter procedure design and operations.

- 7.1.24.3 Should the validation pilot not be qualified as pilot-in-command of a helicopter to be used for a validation flight, another pilot may be assigned to be the Pilot-in-Command provided the validation pilot occupies a control seat and directs the conduct of the validation.

SECTION 7.2: SAMPLE FLIGHT VALIDATION REPORT

FLIGHT VALIDATION REPORT AIRPORT NAME, STATE (Y CODE)

Complete this report to record the results of the flight validation. Those segments that do not apply should be so annotated.

COMMON	SEGMENTS	SEGMENT COMMENT NEED for CHANGE E (Essential) D (Desirable)
Circling		
25/10NM MSA		

APPROACH PROCEDURE (NAME)

SEGMENT	COMMENT	NEED for CHANGE E (Essential) D (Desirable)
Initial		
Intermediate		
Final		
Missed Approach		
Holding		

APPROACH PROCEDURE (NAME)

SEGMENT	COMMENT	NEED for CHANGE E (Essential) D (Desirable)
Initial		
Final		
Missed Approach		
Holding		

DME or GPS ARRIVAL (SECTOR A)

SEGMENT	COMMENT	NEED for CHANGE E (Essential) D (Desirable)
Initial		
Intermediate		
Final		
Missed Approach		

Any previously unidentified obstacles that may affect the procedure can be listed in the table below.

PREVIOUSLY UNIDENTIFIED OBSTACLES			
DESCRIPTION	APPROXIMATE ELEVATION	LOCATION	OWNER (if known)

Certification

1. The specified altitudes of the above instrument procedures have been checked and the procedures are acceptable subject to the above-mentioned changes (if any) being incorporated.
2. The specified altitudes of the GPS Arrival Sector A have been checked and the procedure is acceptable subject to the above-mentioned changes (if any) being incorporated.
3. The aerodrome is currently certified/registered/other.
4. The WDI's are suitable for straight-in approaches to runways and unsuitable for straight-in approaches to runways The suitable WDI's are/are not illuminated.
5. The approach procedures were/were not found to be operationally suitable for straight-in minimas. (Signature of validation pilot)

CHAPTER 8: DESIGN STANDARDS

SECTION 8.1: GENERAL

8.1.1 Procedure Design

8.1.1.1 **Performance Category Groups.** Procedures should normally be designed for category groups. Common grouping is A/B and C/D. Unless specific operational gain is necessary, groups must not be split for OCA penalties of less than 100 ft.

8.1.1.2 **Category E.** Category E procedures will not normally be designed.

8.1.1.3 **Overlapping Procedures.** The primary areas for instrument approach procedures other than DME Arrivals must not be closer than one nautical mile to the primary area of a procedure to a second aerodrome, unless all procedures involved are wholly contained in controlled airspace. Where this is not practical, vertical separation may be used to ensure that a minimum of 1,000 ft is maintained between aircraft on the two procedures.

8.1.1.4 **Airspace Buffers.** Procedures within controlled airspace must be designed so that:

a. horizontally:

- (1) a 1 NM buffer is provided between the airspace boundary and the boundary of:
 - (i) for holding—the primary holding area;
 - (ii) for non-precision approach segments—the primary area;
 - (iii) for precision approach segments—the OAS W and X surfaces.

b. vertically:

- (1) A 500 ft buffer is provided between the nominal aircraft position and an airspace boundary set for VFR level; or
- (2) A 1,000 ft buffer is provided between the nominal aircraft position and an airspace boundary set at a useable IFR level; except for precision approaches where, in addition, the basic ILS surfaces must be wholly contained within the controlled airspace boundary;

c. for the Missed Approach Segment:

- (1) clearance from airspace is determined using a combination of vertical and horizontal dimensions:
 - (i) vertically, the height of the nominal aircraft position in a missed approach is determined by applying the techniques of PANS-OPS Vol II,

- Part III, Chap 7, using a gradient of 5% from the SOC to the missed approach altitude;
- (ii) if this height conflicts with airspace, then horizontally a 1 NM buffer is provided between the airspace boundary and the missed approach primary area.

Note:

If airspace considerations require a nominal gradient greater than 5%, the IAL chart must show a climb gradient identified by an asterisk.

8.1.1.5

Prohibited and Restricted (P and R) Areas. Procedures which cross or abut P and R areas must be designed so that:

- a. where the P or R area contains flying activities:
 - (1) horizontally, the boundary of the P or R area does not infringe:
 - (i) for holding—the primary holding area plus a 1 NM buffer;
 - (ii) for non-precision approach segments:
 - the primary area of Initial and Intermediate Approach segments plus a 1 NM buffer, and
 - the primary and secondary area of the Final Approach segment;
 - (iii) for precision approach segments—the OAS W and X surfaces plus a 1 NM buffer.
 - (2) vertically, the altitude limit over the area must be the vertical limit of the P or R area plus 500 ft, or the altitude dictated by obstacle clearance criteria, if higher.
- b. where the P or R area is not used for flying activities:
 - (1) horizontally, the boundary of the P or R area must not infringe:
 - (i) for holding—the primary holding area;
 - (ii) for non-precision approach segments—the primary area of the Initial, Intermediate and Final approach segments;
 - (iii) for precision approach segments—the OAS W and X surfaces;
 - (2) vertically, the upper limit of the P or R area may be used provided obstacle clearance criteria are met.
 - (3) for the Missed Approach Segment, clearance from airspace is determined using a combination of vertical and horizontal dimensions:
 - (i) vertically, the height of the nominal aircraft position in a missed approach is determined by applying the techniques of PANS-OPS Vol II, Part III, Chap 7 using a gradient of 5% from the SOC to the missed approach altitude;

- (ii) if this height conflicts with a P or R area, then horizontally the missed approach primary and secondary areas must not infringe the P or R area boundary.

Note:

If a gradient of greater than 5% is required, the IAL chart must show the climb gradient identified by an asterisk.

8.1.1.6

Danger Area Associated with High-Velocity Gas Efflux.

Procedures which cross or abut danger areas associated with high-velocity gas efflux must be designed so that:

- a. for procedures based on conventional navigation aids:
 - (1) horizontally, the danger area does not infringe the procedure primary area.
 - (2) vertically, the upper limit of the danger area may be used provided obstacle clearance requirements are met.
- b. for GPS based procedures:
 - (1) horizontally, the nominal final approach and missed approach tracks clear the danger area by a minimum of 1,000 m;
 - (2) vertically, the upper limit of the danger area may be used provided obstacle clearance criteria are met;
 - (3) the missed approach incorporates a minimum turn of 45° away from the danger area.

8.1.2 Procedure Identification

8.1.2.1 Instrument procedure charts must be identified in accordance with ICAO Annex 4 requirements.

8.1.3 Straight-in Non-Precision Approach Procedures

8.1.3.1 Wherever possible, non-precision approach procedures must be designed as straight-in approaches in accordance with the alignment criteria contained in PANS-OPS Vol II.

8.1.3.2 Publication of straight-in minima is limited to aerodromes where the runway conforms to the Non-Precision Approach Runway standards contained in MOS Part 139, with the following exceptions for GPS non-precision approach procedures.

- a. **Runway Width and Strip Width.** Minimum runway width of 30 m and a minimum strip width of 90 m for procedures limited to code 1, 2 and 3C aero planes. For aerodromes with a runway strip width less than 300 m, the MDA must be adjusted in accordance with paragraph 8.1.4.1. Runways accommodating aero planes above code 3C require a

minimum graded runway strip width in accordance with MOS Part 139.

- b. **Approach OLS Area and Gradient.** The approach OLS area and gradient parameters are as per MOS Part 139, except that the length of inner edge may be reduced to a minimum length equal to the runway strip width provided in accordance with paragraph 8.1.3.2a.. Where an OLS area survey to the Non-Precision Approach Runway criteria is not available, a straight-in approach minima may be published, provided the MDA is 500ft or more above the aerodrome elevation and an operational assessment confirms the visual approach path is clear of obstacles. The visual approach path for these purposes commences at the point where the nominal 3° approach path coincides with the planned MDA. The obstacle free plane extends from this "Nominal Intercept Point" at an altitude equal to the MDA minus MOC, to a point 50 ft above the runway threshold. (See Figure 8-1). Laterally, the visual approach path will commence with a width equal to the runway strip width provided and splay at 10% to the visual approach point described above.

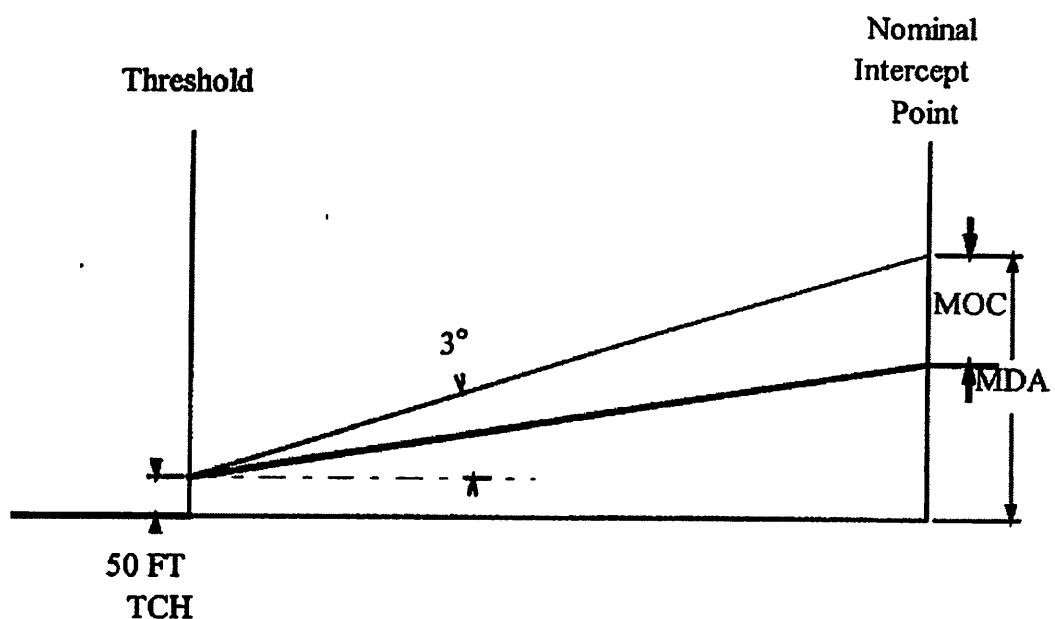

Figure 8-1: Visual descent segment

- c. **Surface Wind Information.** Surface wind information must be provided in accordance with CAO 92.2.
- d. **Runway Edge Lighting.** Runway edge lighting shall have 60 m spacing, except that existing 90 m spacing is acceptable subject to assessment for Non-Precision Approach Runways intended to be used in visibility conditions of 1.5 km or more. The suitability of existing 90 m spaced lighting for night

approaches must be assessed during the instrument approach validation process.

8.1.4 Visual Segment Limitations

8.1.4.1 **Runway Strip Width less than 300 Metres.** Where a straight-in procedure is approved to a runway with a runway strip width of less than 300 m, the minimum OCH for straight-in procedures required must be no lower than the final segment minimum obstacle clearance plus

$$\left(\frac{300 - \text{actual runway strip width}}{2} \times \frac{1}{7} \right) \text{ metres}$$

Note: The minimum OCH for straight-in procedures referred to in paragraph 8.1.4.1 is as follows:

(a) **Precision:**

As determined by OAS or CRM

(b) **Non-precision (without FAF - 295 ft MOC):**

Runway Strip Width (m)	Minimum OCH (ft)
230	311
180	323
150	330
90	344

(c) **Non-precision (with FAF - 246 ft MOC):**

Runway Strip Width (m)	Minimum OCH (ft)
230	262
180	274
150	281
90	295

- 8.1.4.2 **Parallel Runways—Sidestep Procedures.** Sidestep procedures shall have a visual segment ceiling not less than that derived from the following formula:

$$VS = X + \frac{D}{\cos 30^\circ} 318.4 + F$$

Where VS = visual segment ceiling (feet)

X = ceiling for final segment C/L intercept of 30°

Values are:

CAT A: 300

CAT B: 330

CAT C: 435

CAT D: 540

D = distance between parallel runways in nautical miles

F = factor; for CAT A: 48; CAT B: 82; CAT C: 118; CAT D: 153.
(above values are in feet)

8.1.5 OCA and Descent Limits

- 8.1.5.1 In addition to the requirements of PANS-OPS Vol II, the following factors are to be taken into account in determining OCA:

a. **Accuracy of Maps and Charts.** The vertical and horizontal accuracy of the maps and charts used during instrument approach procedure design must be accounted for. In particular:

- (1) if the vertical accuracy of the map or chart cannot be determined a value of ± 10 m must be used;
- (2) if terrain height is being determined from contour information, the height of the highest terrain must be assumed to be the height of the highest contour plus the contour interval of the map;
- (3) spot height information does not attract any accuracy superior to that of contour information—therefore, despite the presence of spot height information, terrain height must be calculated from contour data in accordance with paragraphs 8.1.5.1a.i. and 8.1.5.1a.(ii) above.
- (4) survey control point information and the elevation of the top of some structures are subject to specific survey—therefore, these heights may be used without adding the map/chart vertical accuracy described in this sub-paragraph.

b. **Forecast Altimeter Setting Error.**

- (1) at aerodromes where a 24-hour ATC tower service is not provided, and a TAF is issued on a 24-hour basis (TAF Category 1 or 2 aerodrome), an allowance of 100 ft (3 hPA) must be added to the lowest OCA;

- (2) for aerodromes where a TAF may not be available 24 hours per day, an allowance of 150 ft (5 hPA) must be added to the lowest OCA;
- (3) the published MDA box will be shaded in both cases to permit a reduction of 100 ft to MDA if local QNH is available from an approved source.

c. **Obstacles.**

- (1) all known obstacles, including vegetation, must be accounted for. In addition, an allowance must be made for vegetation growth and the erection of new obstacles in the period between obstacle surveys. The allowance for these factors must be 100 ft over open country or water suitable only for leisure boating and 200 ft over tropical rain forest, open water, or built-up areas. In the event of known obstacles exceeding these values, the greater value must be used.

8.1.6 Visibility

8.1.6.1 Runway Approaches. The basic value for runway approach procedures must be determined using the method described in Section 9.1. Computations using this method are represented in Figure 8-2.

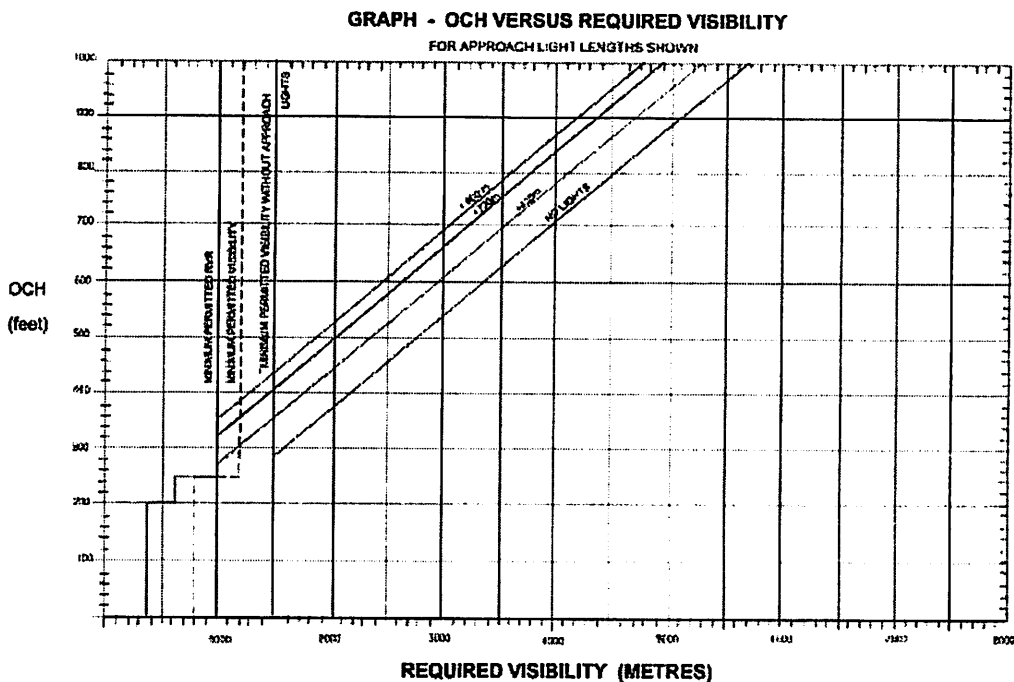

Figure 8-2: OCH versus required visibility

8.1.6.2 **Minimum Values.** The following are the minimum visibility values approved for straight-in procedures.

Table 8-1: Minimum visibility

Lighting and Marking	Category 1		
	DH (ft)	RVR (m)	VIS (m)
HIAL (900 m), HIRL, TDZ, Centreline and RWY marking specified in AIP AD1, sections 3 and 4, for precision approach runways	200-250	550	800
	>250	1,000	1,200
	NB: Centreline and TDZ lights not required		
Short HIAL or approved system, HIRL and RWY marking as above	740 m HIAL		
	200-250	800	800
	Other		
	>250	1,000	1,200
Approved lighting and marking not included above	>250	1,500	1,500

8.1.6.3 **Circling.** Circling visibility must be determined from the following table. (The basis upon which the values for circling visibility have been determined are contained in Section 9.1.)

Table 8-2: Circling visibility

Aircraft Category	A	B	C	D	E
Circling Visibility (km)	2.0	2.4	4.00	5.00	7.00

8.1.6.4 Where a procedure terminates outside the circling area, a visual segment may be provided. The visibility for a visual segment must be 5,000 m.

8.1.7 **State Minima**

8.1.7.1 **Visibility.** The State visibility minima must be the value determined by paragraph 8.1.6, adjusted as follows:

- a. for RVR values up to 800 m, the calculated values must be rounded to the nearest multiple of 50 m;
- b. for RVR values greater than 800 m and visibility values up to 1,000 m the calculated values must be rounded to the nearest multiple of 100 m;

- c. for visibility values greater than 1,000 m, the calculated value must be rounded to the nearest multiple of 200 m.

Exception. For runway approaches it must not be less than the minimum values permitted at paragraph 8.1.6.2.

Note:

The rounding in paragraph 8.1.7.1 may give inappropriate values when determining visibility for foreign procedures. In such cases, the value determined under paragraph 8.1.6 may be rounded to any value within the following range:

1. for RVR values up to 800 m = ± 25 m;
2. for RVR values greater than 800 m = ± 50 m;
3. for visibility values greater than 1,000 = ± 100 m

- 8.1.7.2 **DA/MDA.** The State DA/MDA must not be less than:
 - a. the OCA determined in accordance with ICAO PANS-OPS Vol II and paragraph 8.1.5.
 - b. the visual segment limitations contained in paragraph 8.1.4 above.
 - c. the OCA plus any margin deemed necessary to account for poor ground equipment performance or local conditions.
 - d. threshold elevation plus 200 ft for Category 1 operations.

8.1.8 **Aerodrome Operating Minima (AOM)**

- 8.1.8.1 AOM must be the higher of the OCA corrected for the factors listed in ICAO Annex 6 or the State DA/MDA. For precision approaches, the State DA must be adjusted for pressure error to determine the AOM. Aircraft pressure error correction must be applied or, alternatively, at least 50 ft added to the DA.

8.1.9 **General Alternate Minima**

- 8.1.9.1 The general alternate minima must be calculated by adding the tolerance for the forecast ceiling and visibility to the circling minima (500 ft and 2 km).

8.1.10 **Special Alternate Minima**

- 8.1.10.1 **Airborne Equipment.** Special Alternate Minima are available only for operations by aircraft with dual ILS/VOR navigation capability (that is, with duplicated LLZ, G/P, Marker and VOR receivers). Although not specified and not required, it is assumed that such aircraft will also have duplicated ADF systems.

- 8.1.10.2 **Ground Equipment.** For a location to be considered it must be served by ILS, LLZ or straight in VOR instrument approach procedures to at least two runway directions which are suitable for use by all aircraft likely to use the special low alternate minima.
- 8.1.10.3 The instrument approach procedures should preferably utilise different VHF ground equipment. However, the use of the same ground equipment for both approaches is acceptable provided the equipment meets the requirements of ICAO Annex 10, Volume 1, Attachment C, Table C2 or Attachment F, as applicable, and an alternative straight in instrument approach procedure which utilises a different aid is available.
- 8.1.10.4 **Other Requirements.** Only controlled aerodromes qualify. The Special Alternate Minima shall not be available during any period when ATC and Bureau of Meteorology (BoM) observations and forecasting services are not provided at the aerodrome concerned.
- 8.1.10.5 **Calculation of Special Alternate Minima.** To calculate Special Alternate Minima:
- a. add 500 ft ceiling and 1.5 km visibility to the ceiling and visibility minima of the VHF runway aligned instrument approach procedure which provides the greatest advantage.
 - b. add 400 ft ceiling and 1.5 km visibility to the ceiling and visibility minima of the VHF runway aligned instrument approach procedure to an alternative runway.
 - c. when required by paragraph 8.1.10.3, add 300 ft ceiling and 1.5 km visibility to the ceiling and visibility minima of any other straight-in instrument approach procedure which utilises an aid other than those used in paragraphs 8.1.10.5a. and 8.1.10.5b. above.
- 8.1.10.6 The alternative minimum is the highest of those obtained above. Ceiling values should be rounded out to the nearest 50 ft. Visibility values should be rounded up to the next higher kilometre or half kilometre.
- 8.1.10.7 An extra margin over and above those mentioned above may be added if believed to be necessary because of peculiarities in the local weather patterns and/or difficulties in forecasting.
- 8.1.10.8 **Invalidation of Special Alternate Minima.** Instructions shall be promulgated in appropriate operational documents requiring aircraft operators/pilots-in-command to monitor the availability of required navigation aids and BoM meteorological services. These will include issuing of appropriate instructions requiring the reversion to standard alternate minima during periods when:
- a. local BoM METAR/SPECI are not available;
 - b. BoM forecasting services are not available;

- c. protracted unavailability (ie. greater than 7 days) of any ground equipment associated with the approach aid exists;
- d. an aerodrome control service is not provided.

8.1.11 International IFR Operations Outside Indonesia

- 8.1.11.1 Alternate minima must be determined:
- a. in accordance with paragraph 8.1.9; or
 - b. by adding forecast tolerances for ceiling and visibility to the minima of the second lowest independent approach procedure suitable for the operation and for which the aircraft is equipped.

Note:

If State forecast tolerances cannot be determined, or there is a doubt on the availability/reliability of the approach aid, a ceiling tolerance of 500 ft and visibility tolerance of 2 km must be used.

- 8.1.11.2 Except for ILS with approved Category 1 minima, the procedures used by each navigation system must be independent of each other. In determining alternate criteria, minima lower than ILS Category 1 must not be considered.
- 8.1.11.3 If the aerodrome has straight-in procedures to a runway that is not suitable for the operation and if circling is approved, the alternate minima must not be lower than the circling minima plus the forecast tolerances.
- 8.1.11.4 The approved alternate minima must be the greater of:
- a. the values determined by the foregoing paragraphs;
 - b. the values approved by the State operating the aerodrome;
 - c. 400 ft ceiling and 1,600 m visibility where the values determined in paragraph 8.1.11.4a. above are based entirely on precision landing minima; or
 - d. 800 ft ceiling and 3,000 m visibility where the values determined for paragraph 8.1.11.4a. above are not based solely on precision landing minima.

Notes:

1. Independent means that the two procedures will not utilise a common radio navigation aid.
2. Where provided, a terminal area radar control service may be considered as an independent radio navigation aid for an approach to a point not later than 2 NM prior to the FAF.

- 8.1.11.5 The alternate minima determined above will vary with aerodrome, aircraft and radio aid serviceability and may be assessed only immediately prior to departure.

Notes:

1. Independent means that the two procedures will not utilize a common radio navigation aid.
2. Where provided, a terminal area radar control service may be considered as an independent radio navigation aid for the following parts of the procedure
 - a. **approach.** To a point defined by the DGCA which shall not be later than the FAF
 - b. **missed approach.** After a point defined by the DGCA which shall not be before the acceleration segment.
3. A categorized ILS may be considered as two independent procedures.
4. Operators may select nominal alternate values for ports. However, this does not absolve the captain of his pre-flight planning responsibility referred to in paragraph 8.1.11.5. Further, the operator must demonstrate that the value selected will satisfy paragraph 8.1.11 for all operations, both scheduled and unscheduled which may occur during the calendar period of application of the values selected. The demonstration must account for the three standard deviation wind values for both landing and crosswind components and may account for a downwind landing to the value allowed in the relevant aircraft certification.

8.1.12 Indonesian Differences to ICAO PANS-OPS Vol II

- 8.1.12.1 **Circling Area.** Where the circling area has been segmented to facilitate a lower minima and the missed approach point is located within the NO CIRCLING area, the area should be extended by an arc of no less than 2 NM to include the missed approach point within the

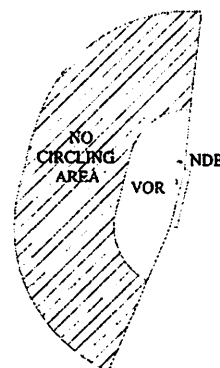

applicable circling area. (See Figure 8-3.) Figure 8-3: Circling area modified to exclude MAPT

8.1.12.2 **Height Above Aerodrome (HAA) and Height Above Threshold (HAT).**

The minima for non-precision approach procedures shall include a HAA, and for precision approach procedures shall include a HAT.

8.1.12.3 GPS Non-Precision Approach Missed Approach Procedures—Use of Secondary Areas. This instruction clarifies the application of secondary areas in the design of GPS NPA missed approach procedures within the Indonesian FIR.

- a. ICAO PANS-OPS Vol II Part III paragraph 33.7.2 and Appendix paragraph 6.5 support the use of secondary areas for GPS NPA missed approach design. However, the text following the asterisks in Figures III-33-6 and III-33-7 state that, until further operational experience is obtained with basic GNSS receivers, the full width of the missed approach area should be treated as the primary area.
- b. Until the ICAO position is reviewed, the following standards are to be applied to GPS NPA missed approach design within the Indonesian FIR. The provisions of PANS-OPS Vol II Part III paragraph 7.2.2 may be used for straight missed approach segments. Secondary areas will not apply to turning missed approach procedures after the earliest turn point on the inner edge of the turn and the intersection of the extended secondary splay and the wind spiral on the outer edge of the turn. Refer to PANS-OPS Vol II Part III paragraph 7.3.5.5 and Figure III-7-23 and III-7-27.

8.1.12.4 Location of missed approach point

- 8.1.12.4.1 For a runway-aligned approach, the missed approach point (MAPt) must be located at or before the threshold.
- 8.1.12.4.2 Where the final approach is not aligned with the runway centre line, the optimum location is the intersection of the final approach course and the extended runway centre line.
- 8.1.12.4.3 The MAPt may be moved closer to the FAF to provide obstacle clearance in the missed approach area provided that the MDA/H is not lower than the altitude/height on the design descent gradient at the MAPt.

8.1.13 Table of Operationally Equivalent Values

- 8.1.13.1 The following metres (m) to statute mile (mile (statute)) or feet (ft) value are deemed to be equivalent for operational purposes.

Table 8-3: Operationally Equivalent Values

Visibility		RVR	
400 m	= ¼ mile (statute)	50 m	= 150 ft
800 m	= ½ mile (statute)	75 m	= 250 ft
1,200 m	= ¾ mile (statute)	100 m	= 300 ft
1,600 m	= 1 mile (statute)	150 m	= 500 ft
2,000 m	= 1 ¼ mile (statute)	175 m	= 600 ft
2,400 m	= 1 ½ mile (statute)	200 m	= 700 ft
2,800 m	= 1 ¾ mile (statute)	300 m	= 1,000 ft
3,200 m	= 2 mile (statute)	350 m	= 1,200 ft
3,600 m	= 2 ¼ mile (statute)	400 m	= 1,400 ft
4,000 m	= 2 ½ mile (statute)	500 m	= 1,600 ft
4,400 m	= 2 ¾ mile (statute)	550 m	= 1,800 ft
4,800 m	= 3 mile (statute)	600 m	= 2,000 ft
		800 m	= 2,400 ft
		1,000 m	= 3,000 ft
		1,200 m	= 4,000 ft
		1,600 m	= 5,000 ft
		2,000 m	= 6,000 ft.

SECTION 8.2: LOWEST SAFE ALTITUDES

8.2.1 Lowest Safe Altitudes

8.2.1.1 ICAO Annex 11 Chap 2 outlines the requirement for the publication of Lowest Safe Altitudes (LSALT) and the criteria to be used for their determination. In particular, it states that the LSALT determined shall be at least 1,000 ft above the highest obstacle located within the area concerned.

8.2.1.2 The purpose of this standard is to outline the rules and parameters to be used for the calculation of LSALT for IFR en-route operations. The particular issues addressed are:

- effective areas;
- charts;
- altitude tolerances;
- ailure of radio navigation aids;
- applicability.

8.2.2 Effective Areas

8.2.2.1 **Route defined by Radio Navigation Aids or by Dead Reckoning.** The area to be considered for the LSALT calculation for a particular route or route segment must be a 5 NM area surrounding and including the route navigation tolerance area. The navigation tolerance must be based on an expanding track tolerance of $\pm 10.3^\circ$

from the navigation aids which provide track guidance, and $\pm 15^\circ$ when no track guidance is available and DR navigation is required to be used. The maximum width of the route navigation tolerance area is 50 NM. For route or route segments served by VORs, the navigation aid coverage to be applied for the determination of the route navigation tolerance area must be the lesser of 60 NM or the maximum coverage published in ERSA. The effective areas for various circumstances are shown at paragraph 8.2.5.

- 8.2.2.2 **Operations with Area Navigation Systems (including GPS).** The area to be considered in specifying the LSALT applicable to any route or route segment must be as defined in paragraph 8.2.2.1 with an expanding track tolerance of $\pm 10.3^\circ$ to a maximum width of 30NM either side of track for conventional area navigation (RNAV) systems and 7 NM for GPS.
- 8.2.2.3 **RNP operations.** For routes flown by aircraft operating under a RNP approval, LSALT may be calculated in accordance with the standards contained in ICAO Doc 8168.
- 8.2.2.4 **Navigation Charts.** In specifying the LSALT for any latitude/longitude grid, only the area within the latitude/longitude grid need be considered.
- 8.2.3 **Charts**
- 8.2.3.1 The chart recommended for plotting navigation tolerance areas and the extraction of terrain/obstacle information is the ICAO 1:1,000,000 WAC Series chart. However, whenever doubt exists concerning the accuracy of the information on the WAC, larger scale maps must be used. The RAAF Joint Operations Graphic (Air) Chart, at a scale of 1:250,000, is ideal for this purpose.
- 8.2.3.2 The terrain to be considered in the determination of the LSALT for any route segment must be:
- a. when heights are shown on charts by spot heights and hachuring only—the highest spot height within the navigation tolerance area.
 - b. where heights are shown on charts as spot heights, contours and hypsometric tints—the highest spot height within the navigation tolerance area or, where there is no spot height, the highest terrain within the intruding contours.
- 8.2.3.3 As spot height information shown on charts may not necessarily indicate the highest terrain in that area, it is necessary to examine the contour information to ensure that no higher terrain exists that would control the LSALT. Further, whenever contour intervals are used to determine the highest terrain, then the highest terrain must be assumed to be at the level of the next higher contour.

8.2.3.4 Obstacles shown on Indonesian produced WACs are generally limited to those having a height of 360 ft (110 m) or more. Therefore, whenever these charts are used for the determination of LSALTs an obstacle allowance of 360 ft must be made. Further, due to this allowance, caution must be exercised when a published tower/mast appears at first to be the critical obstacle. With the addition of the 360 ft obstacle allowance it is possible that the corrected highest terrain within the navigation tolerance area may be higher than the tower/mast first identified as the critical obstacle.

8.2.4 Altitude Tolerance

8.2.4.1 Where the corrected highest terrain (refer paragraphs 8.2.3.3 and 8.2.3.4) in the navigation tolerance area for a particular route or route segment is not above 500 ft, and there are no obstacles above 500 ft, the LSALT must be 1,500 ft. **8.2.4.2** In Indonesia, where the corrected highest terrain or obstacle in the navigation tolerance area for a particular route or route segment is above 500 ft, the LSALT must be 1,000 ft higher than the corrected terrain or obstacle.

8.2.4.3 For operations outside Indonesia where the highest terrain or obstacle in a particular route or route segment is:

- a. above 500 ft but not above 15,000 ft, the LSALT must be 1,000 ft higher than the highest terrain or obstacle, except that where the topographic reliability as shown in the WAC for any portion of the navigation tolerance area for the route or route segment is not 'A' (that is, compiled from accurate topographic maps and surveys), the LSALT must be 2,000 ft higher than the highest terrain in the navigation tolerance area;
- b. above 15,000 ft, the LSALT must be 2,000 ft higher than the highest terrain or obstacle in the navigation tolerance area.

8.2.4.4 The altitude calculated in accordance with the above must be rounded up to the next highest 100 ft increment.

8.2.5 Navigation Tolerance Area Construction—Examples

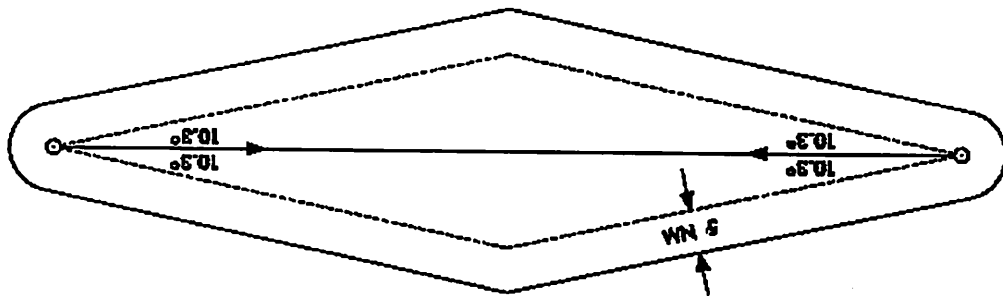

Figure 8-4: Overlapping nav-aid coverage on route segment with each coverage half length of segment or more or coverage of destination nav-aid half length of segment or more

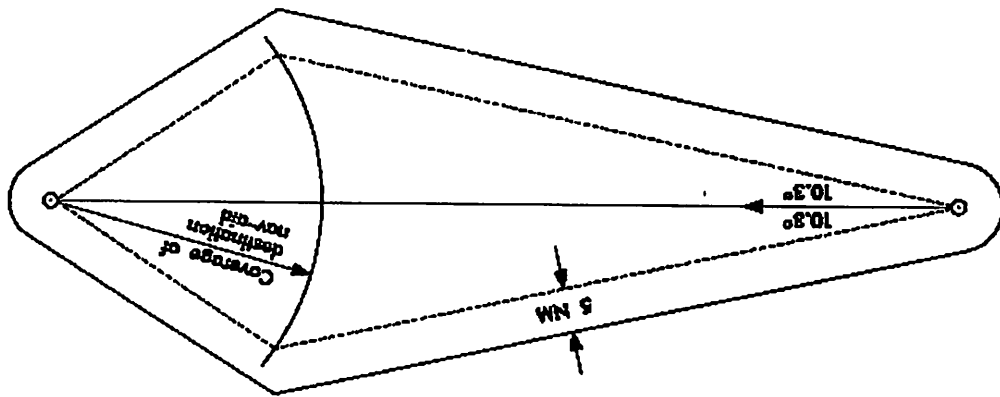

Figure 8-5: Coverage of destination nav-aid less than half-length of segment

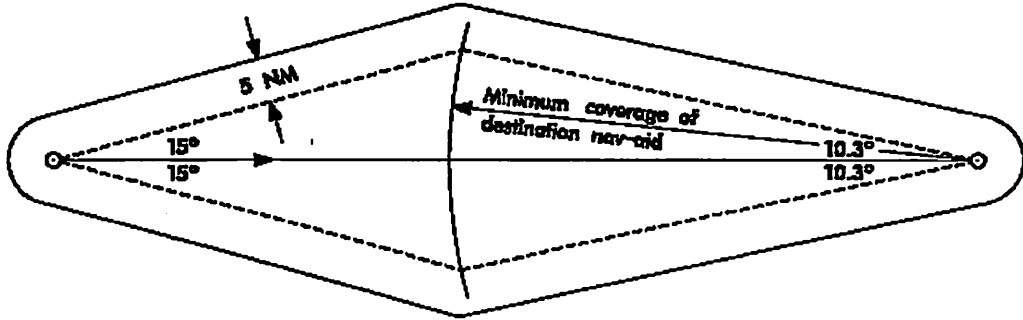

Figure 8-6: No nav-aid at departure aerodrome, nav-aid at destination with coverage such that 10.3° lines intersect 15° lines from departure aerodrome

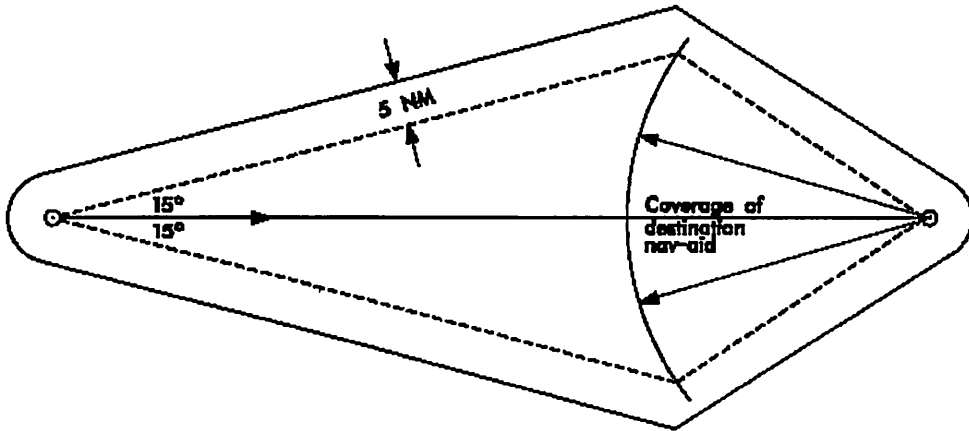

Figure 8-7: No nav-aid at departure aerodrome, nav-aid at destination with coverage such that 10.3° lines do not intersect 15° lines from departure aerodrome

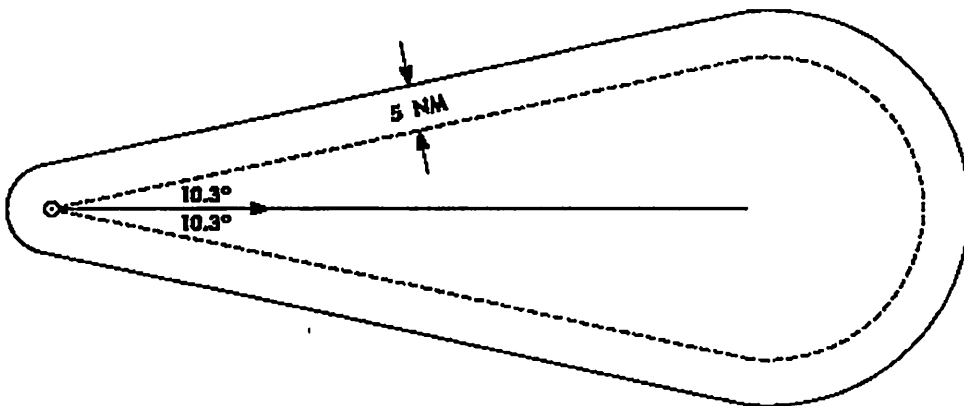

Figure 8-8: Nav-aid at departure aerodrome, no nav-aid at destination—segment distance not exceeding 275 NM (10.3° diverges 50 NM in 275 NM)

Figure 8-11: Route segment without nav-aids—segment distance exceeding 186 NM

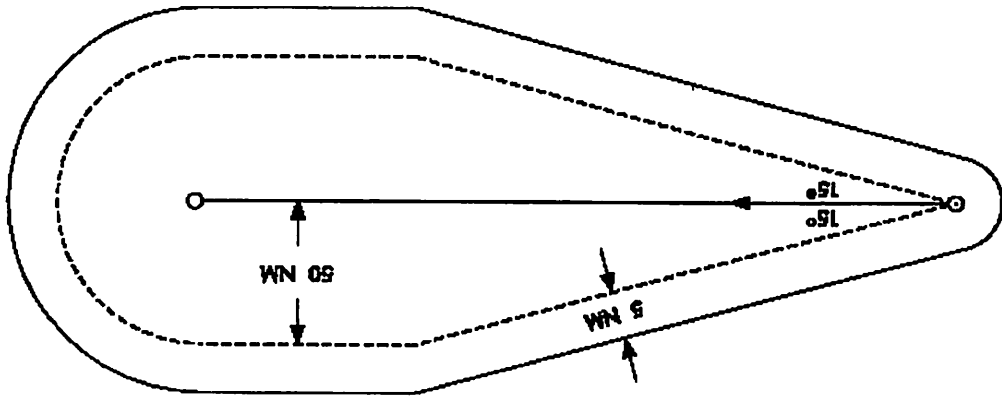

Figure 8-10: Route segment without nav-aids — segment distance not exceeding 186 NM (15° diverges 50 NM from track in 186 NM)

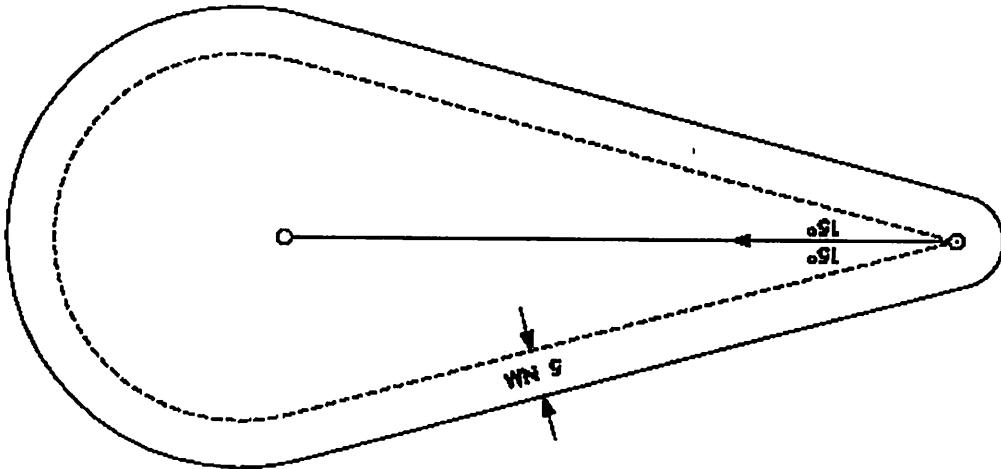

Figure 8-9: Nav-aid at departure aerodrome, no nav-aid at Destination—segment distance exceeding 275 NM

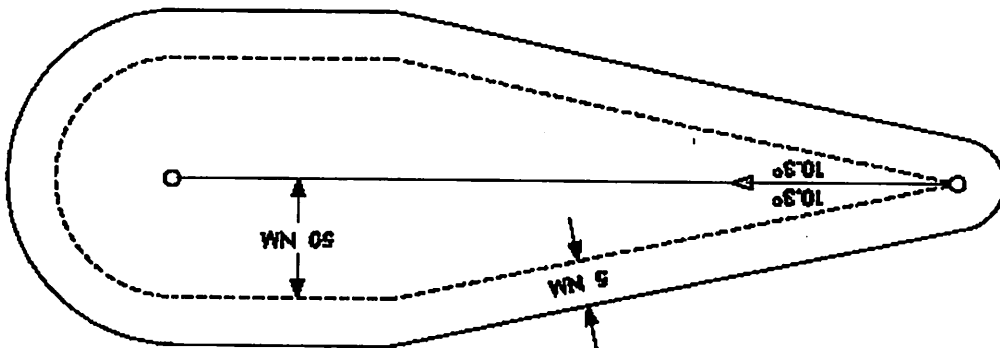

Figure 8-14: Route segment with change of direction at D.R. position — coverage of destination nav-aid not less than length of second sector of route segment

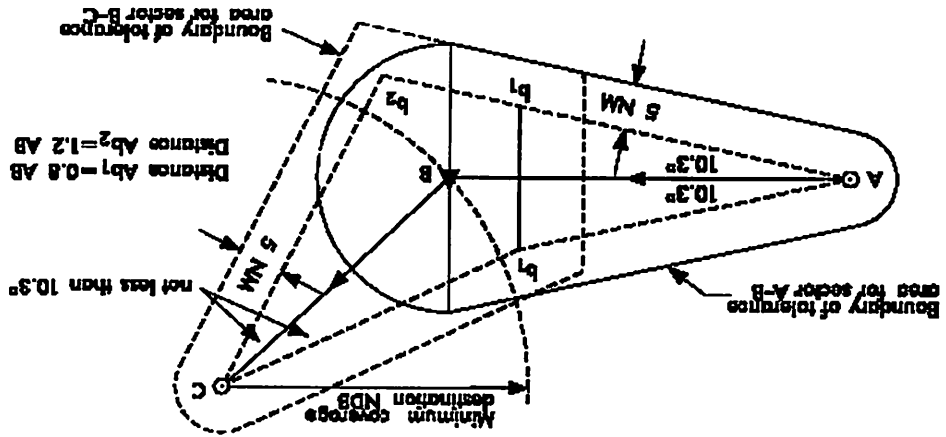

Figure 8-13: Route segment with intermediate reporting point (no positive fix) basic area for A-B is ADEF and for B-C is GDCE

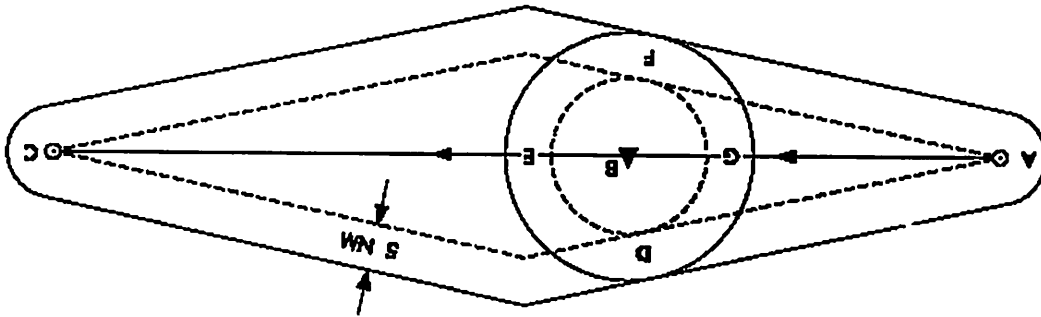

Figure 8-12: As for Figure 8-5, but 10.3° lines expand to maximum distance of 50 NM either side of track—in no case is the maximum width of basic area inside 5 NM buffer are greater than 50 NM either side of track

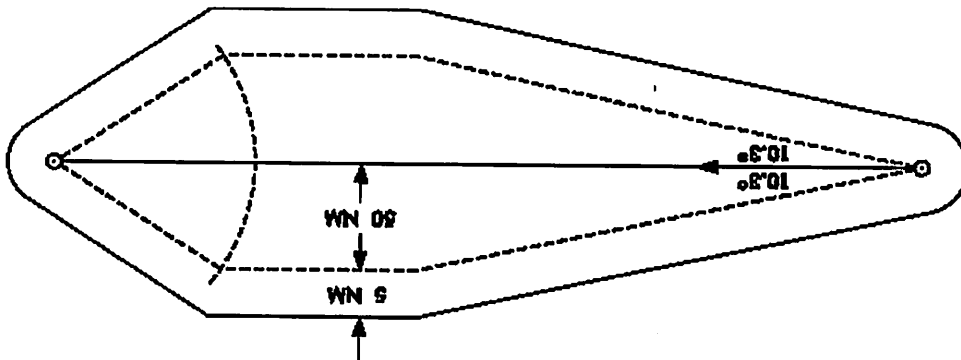

Figure 8-16: Route segment with change of direction at DME/azimuth aid fix—coverage of destination nav-aid not less than length of second sector of route segment (NB: diagram shows DME at A; DME fix area would be different if DME at another position)

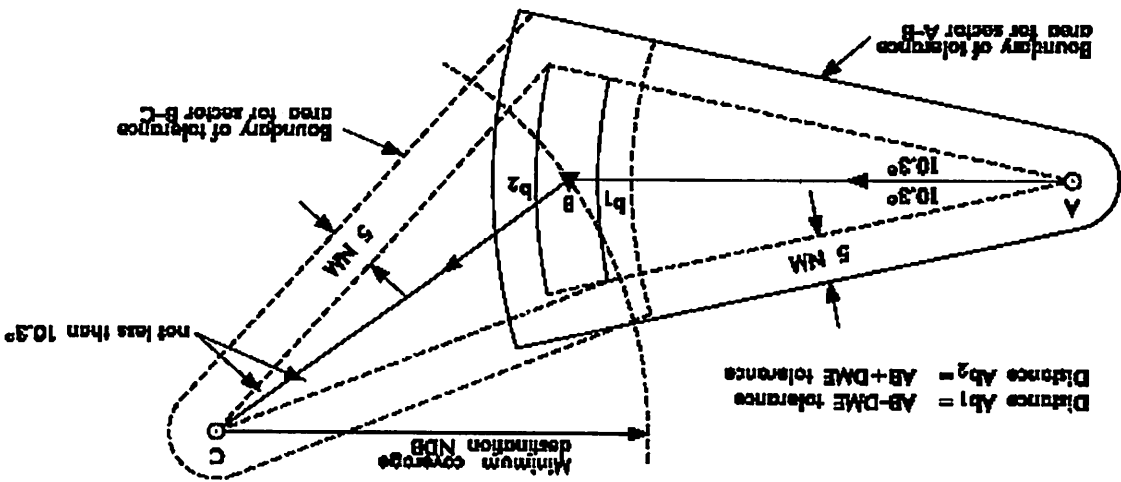
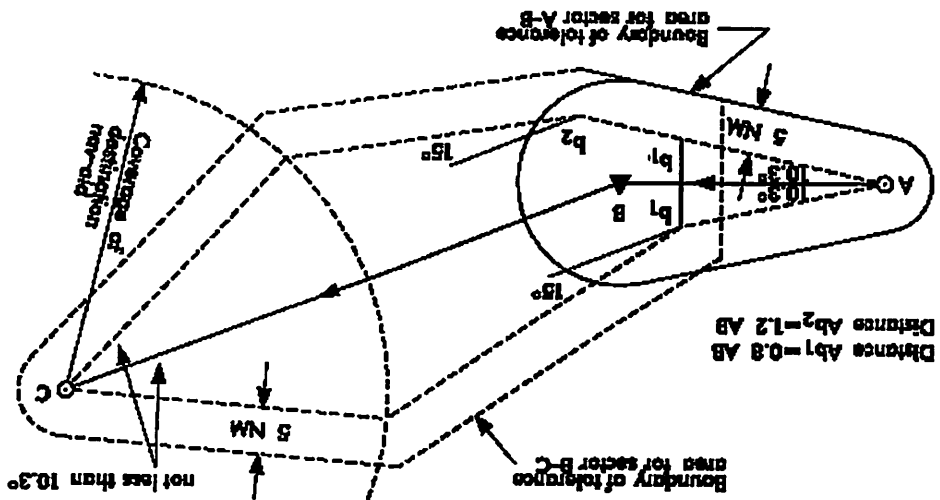

Figure 8-15: Route segment with change of direction at D.R position—coverage of destination nav-aid less than length of second sector of route segment



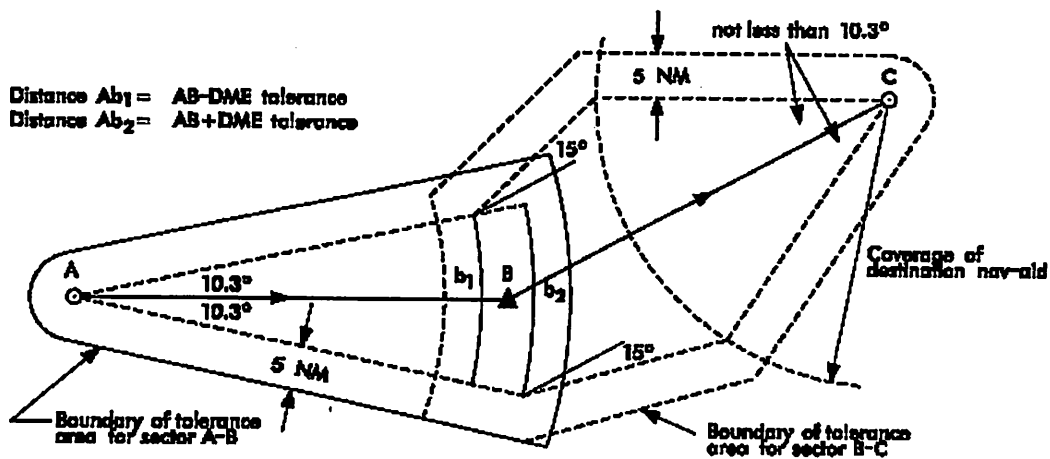

Figure 8-17: Route segment with change of direction at DME/azimuth aid fix— coverage of destination nav-aid less than length of second sector of route segment (NB: diagram shows DME at A. DME fix area would be different if DME at another position)

SECTION 8.3: DME/GPS ARRIVALS

8.3.1 Introduction to DME/GPS Arrival Procedures

8.3.1.1 A DME/GPS arrival procedure is designed to permit an aircraft to descend from an en-route altitude at or above the lowest safe altitude to a minimum altitude at an aerodrome using DME or GPS distance measurement and ground based azimuth guidance facilities. The procedure is prescribed for particular tracks or sectors and takes the form of a series of descending steps at appropriate distances.

8.3.1.2 The procedure normally uses a DME that is located close to the azimuth facility but in some cases use is made of a remote beacon. Procedures must be contained within the demonstrated coverage of the navigation aids used. Where more than one tracking aid exists at an aerodrome, tracking is normally permitted to either aid. However, only one GPS reference waypoint is nominated as the GPS distance source. The GPS reference waypoint is either the position of the azimuth aid nearest the DME for DME/GPS procedures, or the position of the primary azimuth aid for GPS only procedures. Azimuth and distance tolerances must be accounted for when determining obstacle or airspace clearance.

8.3.1.3 In designing a DME/GPS arrival, allowances are to be made for terrain clearance, navigational tolerances and errors in DME/GPS distance measurement. In addition, steps are to be designed to maintain an aircraft in controlled airspace where this is applicable to

the particular route. Details of the allowances are set out in the following paragraphs.

8.3.2 DME/GPS Arrival Procedure Design

8.3.2.1 DME/GPS arrivals are instrument approach procedures. DME and DME/GPS arrival procedures are not included in ICAO DOC 8168 – OPS/611 Volume II, but are designed using the criteria contained in that document applicable to non-precision approaches and therefore have initial, intermediate and final approach segments. To account for control area steps, the step information is frequently extended beyond the initial approach fix (IAF) into the en-route segment. The method of blending the en-route segment to the procedure is shown in Figure 8-18. Should the procedure be for a sector, the centre line of Figure 8-18 is expanded by the size of the sector (Figure 8-19).

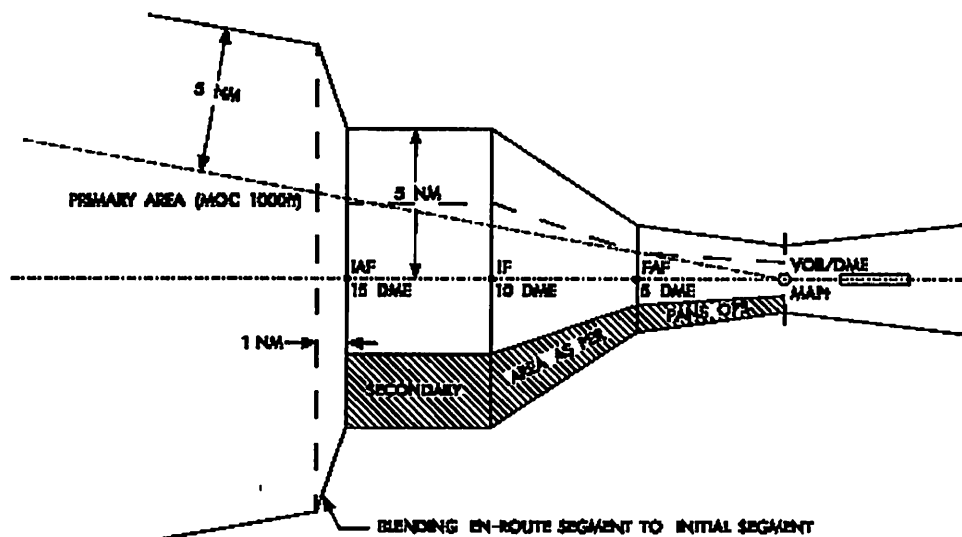

Figure 8-18: Track DME/GPS arrival

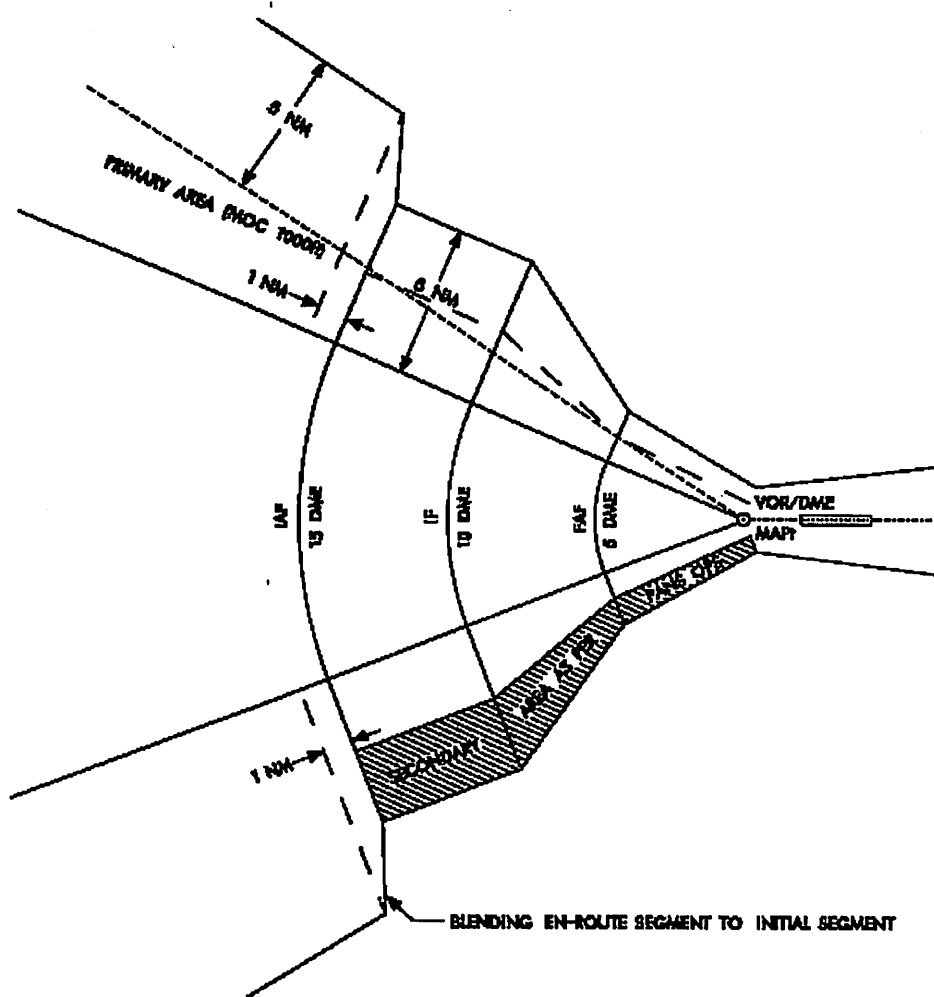

Figure 8-19: Sector DME/GPS arrival

8.3.2.2

DME/GPS arrivals shall:

- a. not terminate below the circling minima.
- b. normally have the following segment lengths (variations must be noted on charts by reference to DME distance):
 - i. initial segment—5 NM;
 - (ii) intermediate segment—5 NM;
 - (iii) final segment—as required;

Example:

If a procedure is based on a DME which is 1 NM beyond the azimuth aid and the procedure has standard length segments, the DAP would have to show 'IAF 16 DME, FAF 6 DME'.

- c. be designed with a MAPT;
- d. assume that manoeuvring across sectors is minimized after the intermediate fix;
- e. not utilize the 15% horizontal gradient provisions of PANS-OPS Vol II paragraph 2.8.4 for sector procedures except in the final segment.

8.3.2.3 The navigation tolerances applicable to the facility which may be used to assist azimuth guidance are contained in ICAO PANS-OPS Chap 2, as are those applicable to DME. The GPS fix tolerance is 2NM for segments at or beyond 25NM from the nominated reference aid (based on GPS receiver operating in the en-route mode) and 1 NM for segments within 25NM of the nominated reference aid (based on the receiver operating in the terminal mode).

8.3.3 Obstacle Clearance

8.3.3.1 Minimum obstacle clearance is as follows:

- a. initial approach and en-route segments – 1,000 ft;
- b. intermediate approach segment – 500 ft;
- c. final approach segment – 300 ft.

Note:

1. No allowance may be made in the final segment MOC for the use of a FAF.
2. When determining the height of terrain from contours, the next highest contour to that included in this splay will be used for clearance purposes.

8.3.4 DME/GPS Steps

8.3.4.1 These steps are determined by the radius of an arc drawn from the DME beacon or GPS reference waypoint through the primary and secondary areas. It will determine the passage of obstruction and/or control area steps or boundaries significant to the last prescribed altitude. To this radius is applied the appropriate DME or GPS fix tolerance as specified in paragraph 8.3.2.3.

8.3.4.2 Except in cases of control area boundaries, DME/GPS steps will provide descent to altitudes lower than the lowest safe altitude for the route segment.

8.3.4.3 The design of the steps should be such as to ensure that an aircraft will be able to conduct a normal type of descent without detriment to the efficiency of the procedure. For instance, the steps should be so arranged that a steady descent will result, rather than a series of steps, which if followed by an aircraft, would require large variations in the rate of descent. Figure 8-20 shows an example of good design.

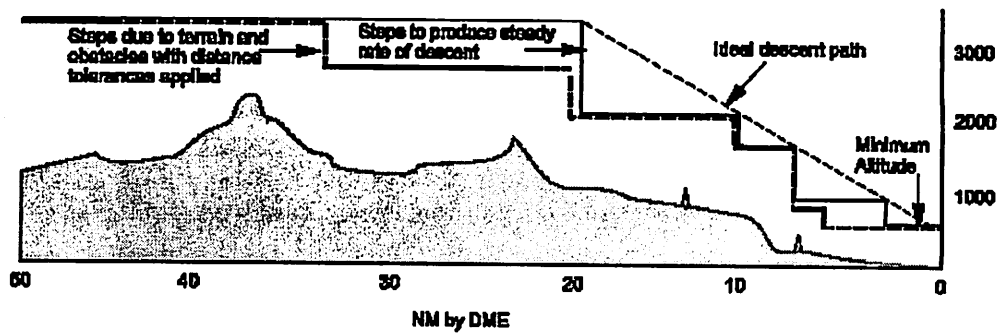

Figure 8-20: DME/GPS arrival steps

8.3.5 Minimum Altitudes

8.3.5.1 The minimum altitudes applicable to DME/GPS arrivals will normally be the circling minimum altitudes associated with the azimuth facility. In many cases, however, it is not possible for an aircraft to descend to these altitudes, due to limitations imposed by preceding DME/GPS steps. In such cases a higher MDA may be necessary. Depending on the direction of approach it may be decided to integrate the DME/GPS arrivals with a procedure already prescribed in AIP DAP.

8.3.6 Missed Approach

8.3.6.1 The MAPT is either the azimuth facility or a point prior to this facility, and is identified for each procedure together with the 'Missed Approach' instruction on the procedure plate.

8.3.6.2 The missed approach areas and the obstacle clearance criteria are the same as those for Instrument Approach and Landing Procedures and are outlined in ICAO PANS-OPS, Vol II Part 3 Chap 7.

8.3.7 Method of Production

- 8.3.7.1 The following steps must be followed in designing DME/GPS Arrivals.
- a. Obtain appropriate WAC, 1:250 000 Military Map, 1:100,000 MAP, ERC (Area Chart VTC if available) and instrument approach chart. Ensure that the latest issue of each chart is obtained.
 - b. Plot the required track or sector on the WAC and largest scale map available.
 - c. Plot the primary and secondary axes around the required track or section in accordance with Figure 8-18 and Figure 8-19.
 - d. From the ERC or Area Chart determine En-route, LSALT and airspace steps (CTA).

- e. List the elevation and DME/GPS distances of terrain and obstructions in descending order within the tolerance areas, commencing at the point where descent below the LSALT first becomes possible. In the calculation of obstacle heights, additional clearance should be made for chart error, mountainous terrain, vegetation and built-up areas.
- f. Add to the identified obstacles the applicable MOC required by paragraph 8.3.3.
- g. Plot the obstacles on a sheet of graph paper, after the determination of a suitable DME distance v Altitude scale. Then, at the top of each obstacle construct a vector parallel to the DME/ALT line and toward the navigation aid, equal to the applicable DME or GPS tolerances (see paragraph 8.3.2.3).
- h. Construct MOC DME/GPS steps by drawing a broken line from en-route LSALT to each of the corrected obstacle positions to minimum altitude (see Figure 8-21).

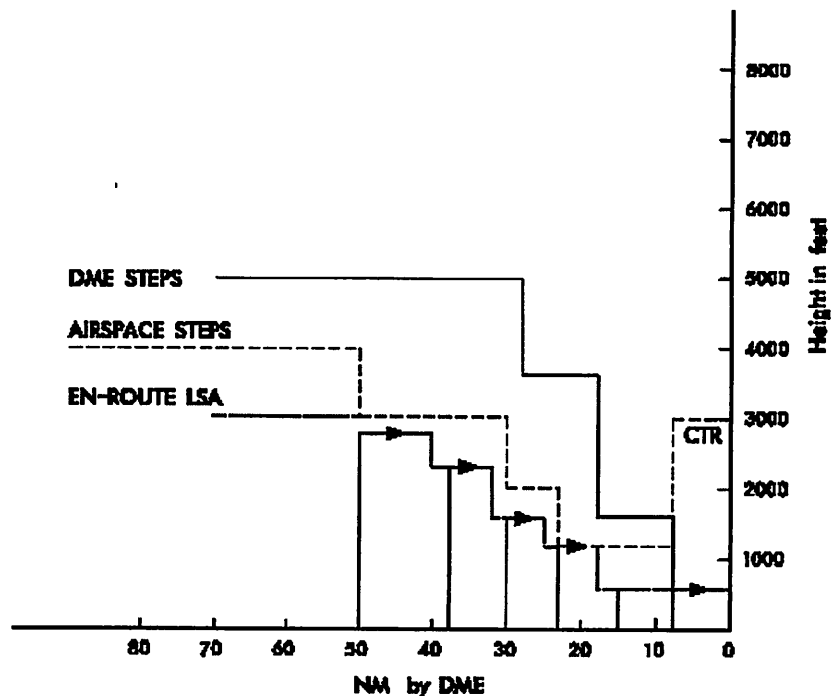

Figure 8-21: DME/GPS steps

- i. If the route or sector is in controlled airspace, it will be necessary to arrange the descent steps so that an aircraft is kept 1,000 ft or 500 ft (as applicable) above the lower limit of the controlled airspace at all times, as well as maintaining the minimum terrain clearance.
- j. It is desirable to provide a steady rate of descent through the steps, (that is, one that can be comfortably achieved by unpressurized aircraft and easily achieved by pressurized aircraft). For this purpose 160 ft per NM is a satisfactory figure. This rate of descent, represented by the full line in

Figure 8-21, extends to the minimum altitude without infringing any of the terrain clearance steps that are represented by the dotted line.

SECTION 8.4: STANDARD TERMINAL ARRIVAL ROUTES (STARS)

8.4.1 STAR Standards

- 8.4.1.1 Standard Terminal Arrival Routes (STARs) must be designed in accordance with the following standards:
- a. RNAV systems are not to be used as the primary navigation reference below the en-route Lowest Safe Altitude;
 - b. STAR procedures employing RNAV waypoints must be identified as RNAV procedures on the associated STAR charts;
 - c. STARs should be seamless from the en-route cruise level to:
 - (1) the initial fix of an instrument approach; or
 - (2) A fix from which radar vectors to the runway centreline are given; or
 - (3) for domestic flights only, a fix from which a visual approach is given.
 - d. holding patterns must be restricted to one per STAR.
 - e. the minimum crossing angle between STAR and Standard Instrument Departure tracks should be 45°.

SECTION 8.5: STANDARD INSTRUMENT DEPARTURES (SIDS)

8.5.1 SID Standards Reserved

SECTION 8.6: HELICOPTER OFF-SHORE PROCEDURES—AIRBORNE RADAR

8.6.1 Application

- 8.6.1.1 An Authorized designer may design procedures in accordance with this section provided that the platform is located 30 NM or more from the nearest land.
- 8.6.1.2 Procedures at other sites (within 30 NM of land) must be designed by a certified designer.

8.6.2 Administration

- 8.6.2.1 Completed designs are forwarded to the relevant DGCA Area Office and to DGCA Airspace, Air Traffic and Aerodrome Standards Branch.

- 8.6.2.2 The DGCA Area Office is responsible for:
- a. issuing designs to approved operators;
 - b. advising Airspace, Air Traffic and Aerodrome Standards Branch of those operators that have been issued with the procedure; and
 - c. forwarding to Airspace, Air Traffic and Aerodrome Standards Branch a copy of the relevant part of the approved operator's operations manual(s).

- 8.6.2.3 DGCA Airspace, Air Traffic and Aerodrome Standards Branch is responsible for:
- a. maintaining a register of procedures; and
 - b. maintaining a register of operators who have been Authorized to use each procedure, and the associated company operations procedures.

8.6.3 Limitations

- 8.6.3.1 The following limitations apply to these procedures:
- a. these procedures may be approved for multi-pilot operations only;
 - b. these procedures are only available for use with radar range presentations of 25 NM or less;
 - c. the target's primary radar return must be displayed for the duration of the airborne radar procedure.

8.6.4 Airborne Radar Equipment/Ground Radar Equipment

- 8.6.4.1 Requirements for airborne and ground radar equipment are detailed in paragraphs 8.6.4.2 and 8.6.4.3.

- 8.6.4.2 **Airborne Radar Equipment.** Any airborne weather radar system may be assessed for use with the procedures described in this standard. The only limitations to this are:
- a. airborne radar approach procedures must not be used with range displays in excess of 25 NM;
 - b. the pilot responsible for radar interpretation must have access to all radar controls and must be in a position to interpret the radar presentation without significant parallax error;
 - c. secondary returns must not obscure the primary returns and must occur behind them;
 - d. secondary returns must not be so remote from primary returns as to permit confusion with a second primary return;
 - e. the primary return must be displayed throughout the entire radar procedure.

- 8.6.4.3 **Ground Equipment.** Radar transponders may be used to assist target identification within the constraints listed above.

- 8.6.4.4 **Data Required for Procedure Assessment.** The following characteristics of the airborne radar equipment must be determined prior to any IAL assessment:
- a. effective vertical beam-width;
 - b. scan rate;
 - c. along track scope graticule distance in the range setting specified for use during the approach procedure;
 - d. across track graticule distance at 5 NM range in the range setting specified for use during the procedure.
- 8.6.5 **Flight Crew Techniques**
- 8.6.5.1 Flight crew techniques, which must be accounted for in the Operations Manual before procedures may be approved, are detailed in paragraphs 8.6.5.2 to 8.6.5.7.
- 8.6.5.2 **Crew.** Airborne radar procedures may be approved for multi-pilot operations only.
- 8.6.5.3 **Radar Interpretation.** Interpretation of radar pictures is to assume that the nearest point of the target and distances and flight operating tolerances must be measured from this point. No allowances may be made for beam width error, pulse length error or spot size error.
- 8.6.5.4 **Flight Crew Operating Tolerances.** For use of radar interpretation of flight operating tolerances operators may elect to round values up. Rounding down below values determined by this standard is not permitted.
- 8.6.5.5 **Radio Altimeters.** Ocean surface swell can cause a fluctuation in the measured radio altitude. This fluctuation should be disregarded until it exceeds 45 ft when the minimum altitude must be increased by the value of the excess.
- 8.6.5.6 **Obstacle Clearance Check.** The obstacle clearance check must be achieved between the validation fix and the commencement of descent fix. The procedure is to:
- a. validate the target return;
 - b. lower antenna elevation until the target return is just retained in the top of the sweep;
 - c. ensure no obstacles are between the target return and the last step down fix.
- 8.6.5.7 **Tracking.** Radar procedures assume that crews make every effort to track from the validation fix to destination.

8.6.6 Types of Procedures

- 8.6.6.1 The following procedures may be designed using airborne radar position lines:
- a. procedures that utilize conventional radio navigation aids for azimuth guidance and airborne radar position lines for along track fixes;
 - b. procedures that utilize only radar position lines.
- 8.6.6.2 Examples of the types of procedures are given at paragraph 8.6.17.

8.6.7 Procedure Design Principles

- 8.6.7.1 The principles to be followed during design of procedures must agree with PANS-OPS Vol II, but additional principles are:
- a. any radar targets that must be identified for the procedure must have their position validated from independent navigation techniques that meet the requirements of AIP;
 - b. once a radar contact has been validated the aircraft must be in continuous receipt of the contact until procedure completion.

Note:

This precludes any procedure that commences over the required radar contact.

- 8.6.7.2 Radar may be utilized to ensure an absence of obstacles in the final segment. These procedures must account for the vertical geometry of the radar beam and ensure that the associated final segment step-down fix is contained within the area searched by the radar (paragraph 8.6.17 refers). Unless the effective vertical beam width of the radar can be determined, procedure designs must use a value of 3° for effective vertical beam width.
- 8.6.7.3 Radar target validation must be achieved within 15 NM of the target return and the validation fixes must be shown on the instrument approach chart.

8.6.8 Procedure Design Tolerances

- 8.6.8.1 Where conventional navigation aids are used for guidance or position lines the allowances and design principles outlined in the PANS-OPS Vol II apply.
- 8.6.8.2 Where airborne radar position lines are used the following tolerances apply.

- (a) **Along track:** $\pm (0.75 + \text{SRA} + \text{B}) \text{ NM}$
- (b) **Across track:**
 - (i) **Drift Corrected presentation** — $\pm (\frac{3}{4} + \text{SRA} + \text{FTT} + \text{C}) \text{ NM}$
 - (ii) **Uncorrected presentation** — $\pm (1 + \text{SRA} + \text{FTT} + \text{C}) \text{ NM}$.

In the above, SRA = Scan Rate Allowance

$$= \frac{(V + 2H + 47)}{60R}$$

FTT = Flight Technical Tolerance

$$= \frac{(V + 2H + 47)}{600}$$

where V = maximum permitted IAS (kt) at the initial approach altitude for the procedure, at ISA+15°C conditions

H = altitude in thousands of feet.

R = number of complete scan cycles per minute

Note:
 This corresponds to allowances of one scan for SRA and 6 seconds for EFT, at the maximum permitted IAS, plus an ICAO wind factor.

8.6.8.3

B and C Values.

The above values are minimum values and apply to all radars. The following allow for scope scale and graticule and must be added to the above values.

a. Along track (value B):

- (1) Graticule 1 NM or less — no correction necessary.
- (2) Scope graticule in excess of 1 NM —

$$\frac{(\text{Graticule division nm} - \frac{1}{4})}{4} \text{ NM}$$

b. Across track (value C)

Radial or vertical graticule—any positive value of: (distance in NM depicted by graticule interval at 5 NM range) — $\frac{1}{4} \text{ NM}$

8.6.9

Procedure Area

8.6.9.1

For an airborne radar approach, the protected area must be 2 NM wide at the primary radar target (1 NM on either side of the target), expanding to a total width of 4 NM at a range of 10 NM from the primary target. The principle of secondary areas does not apply. At greater ranges, the area has a constant total width of 4 NM. The

maximum length of the area must be 15 NM from the primary radar target.

8.6.10 Flight Crew Operating Tolerances

8.6.10.1 Radar tracking tolerance must not exceed 0.75 NM. This information must be published in the operations manuals of approved operators.

8.6.11 Minima Determination

8.6.11.1 **Obstacle clearance.** Minimum obstacle clearance must be in accordance with ICAO PANS-OPS Vol II DOC 8168, except that final segment minimum obstacle clearance must be 300 ft when pressure altimetry is being utilized and 200 ft when radio altimetry is being used.

8.6.11.2 Unless radar procedures verify an absence of obstacles, an additional allowance of 200 ft (ASL) or known height, must be made for observed obstacles within 4 NM of the facility in the overshoot path, or within 1 NM either side of the approach path.

8.6.11.3 All minima must account for a wave obstacle height of 45 ft.

8.6.12 Values

8.6.12.1 In determining minima, minimum altitudes must be rounded up to the nearest 10 ft and visibilities must be rounded up to the nearest half kilometre.

8.6.13 Minimum Altitudes

8.6.13.1 The BARALT minimum must be factored to account for tidal rise and fall in excess of 10 ft when used with respect to sea-borne landing sites. Similarly, a RADALT minimum must be factored in relation to operations at installations that are fixed.

8.6.14 Visibility

8.6.14.1 The required visibility must be:

- a. **Straight-in.** The greater of:
 - (1) the nominal missed approach point to rig distance; or
 - (2) the distance required to decelerate from the maximum permitted TAS finals at (ISA+15)°C to the hover.
- b. **Circling.** As defined by the formula in paragraph 8.6.16.

8.6.15 Missed Approach Point (MAPT)

8.6.15.1 A radar defined MAPT may not be closer to the reference target than the airborne radar's near echo suppression range.

8.6.16 Obstacle Avoidance Determination

Note:

Calculation of the minimum visual segment visibility is based on the CAR 157 guidance to avoid obstacles by 600 m horizontally.

Data

CAR guidance	600 m
Obstacle recognition time	6 sec + 150 m
PANS-OPS bank establishment time	5 sec
Bank angle	The lesser of rate 1° or 25°
Wind	47 + 2H knots $(H = \frac{\text{altitude}}{1000})$
TAS	Maximum TAS permitted at ISA + 15°C.

Calculation

Obstacle avoidance	= 600 m	= A
Turn radius (for calculation see PANS-OPS)		= B
Recognition and bank establishment		= C
11 x (TAS + 47 + 2H) + 150		
Turn point to obstacle distance	= $((A + B)^2 - B^2)^{1/2}$	= D
∴ Visibility required = C + D		

8.6.17 Helicopter IALs

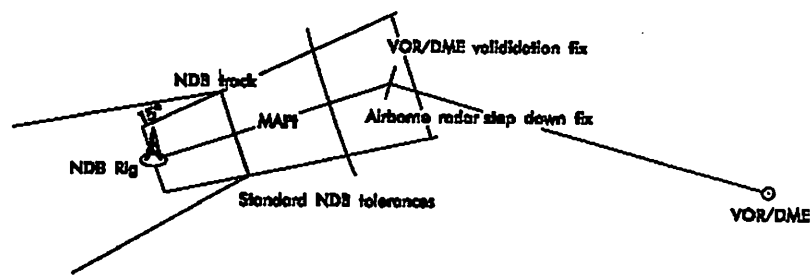

Figure 8-22: Azimuth aid assisted — plan

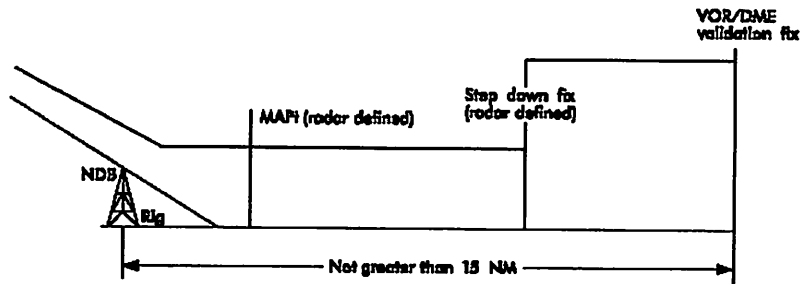

Figure 8-23: Azimuth aid assisted — side

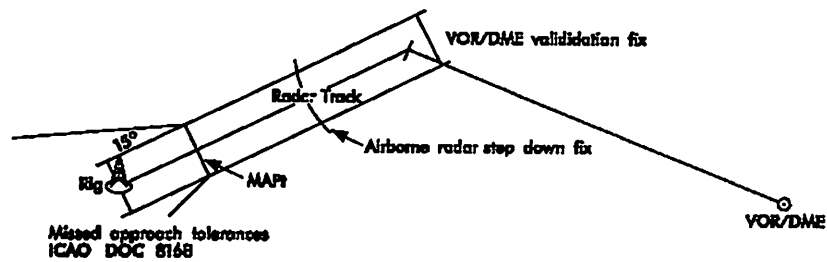

Figure 8-24: Radar only — plan

- 8.6.17.1 An obstacle clearance check must specify the:
- search altitude; and
 - descent commencement fix.
- 8.6.17.2 This specification must ensure that, from the search altitude at the descent commencement fix, the effective beam width will scan an along-track surface segment, which includes both the target and the final step-down fix. Figure 8-26 refers.

Figure 8-27: Offshore rig—airborne radar approach

**AIRBORNE RADAR APPROACH
OFFSHORE RIG**

AP Number:

DME DIST	4.0	6.5	8.0	4.5	4.0	8.5	3.0	2.5	2.0	0.75
ALT	1500	1370	1210	1050	890	730	570	410	250	250

CATEGORY	H
LDG-BAD ALT	250' (250-1.5)
LDG-BAR-ALT	350' (350-1.5)
ALTERNATE	(1000-4.0)

* INCREASE MDA BY 100 FT FOR KNOWN OBSTACLE HEIGHT OBSERVED WITHIN 1 NM OF FACILITY IN THE OVERSHOOT PATH, OR WITHIN 1 NM EITHER SIDE OF APPROACH PATH.

NOTES

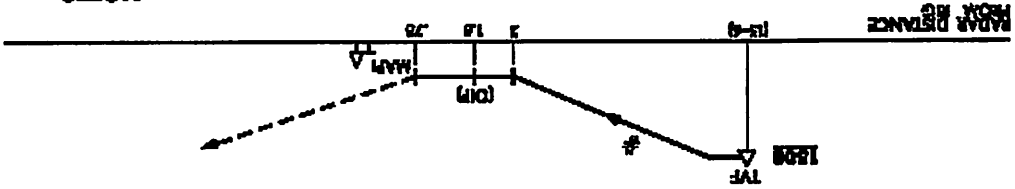

MAINTAIN APPROACH AT 0.75 NM RANGE FROM RIG IN SAME DIRECTION AS LONG AS WIND CORRECT TO 1200 FT.

CAUTION: IF DEPT ANGLE IS GREATER THAN 10 DEGREES, APPROACH MUST BE DISCONTINUED.

LIMITATION: 1. MAX IAS FOR PROCEDURE 80 KT
2. IAS ON FINAL LEVEL SEGMENT 70 KT

NOTE: AT 1.5 NM RADAR RANGE MAKE A 12° HEADING ALTERATION (LEFT OR RIGHT) TO CREATE A 2 NM PARALLEL TRACK TO DESTINATION.

TVP (0.75 NM FROM FACILITY)

TVP ESTABLISHED WITH REFERENCE TO APPROVED NAV SYSTEM

ATIS	AREA	FACILITY	Departure on Request Elections in FEET AMSL
------	------	----------	--

**AIRBORNE RADAR APPROACH
OFFSHORE RIG**

USE QNH

Changes New Procedures.

Figure 8-28: Offshore rig-NDB-airborne radar approach

NDB-AIRBORNE RADAR APPROACH

OFFSHORE RIG
 **2. MINIMUM OUTBOUND
 DISTANCE 6 NM TO
 ACHIEVE INBOUND
 TRACK CLEARANCE
 CHECK BY 4.5 NM

NOTES
 =1. INCREASE MDA BY
 100 FT (OR KNOWN
 OBSTACLE HEIGHT)
 OBSERVED WITHIN
 7 NM OF FACILITY
 IN THE OVERSHOOT
 PATH, OR WITHIN
 1 NM EITHER SIDE
 OF APPROACH PATH

ALT	1200	1050	890	730	570	410	250
RADAR DIST	5.0	4.5	4.0	3.5	3.0	2.5	2.0

Alt. Altitude

CATEGORY	H	HELICOPTER USE ONLY
LDC-RAD ALT	250° (250-1.5)	
LDC-BAR-ALT	350° (350-1.5)	
ALTERNATE	1000-4.0)	

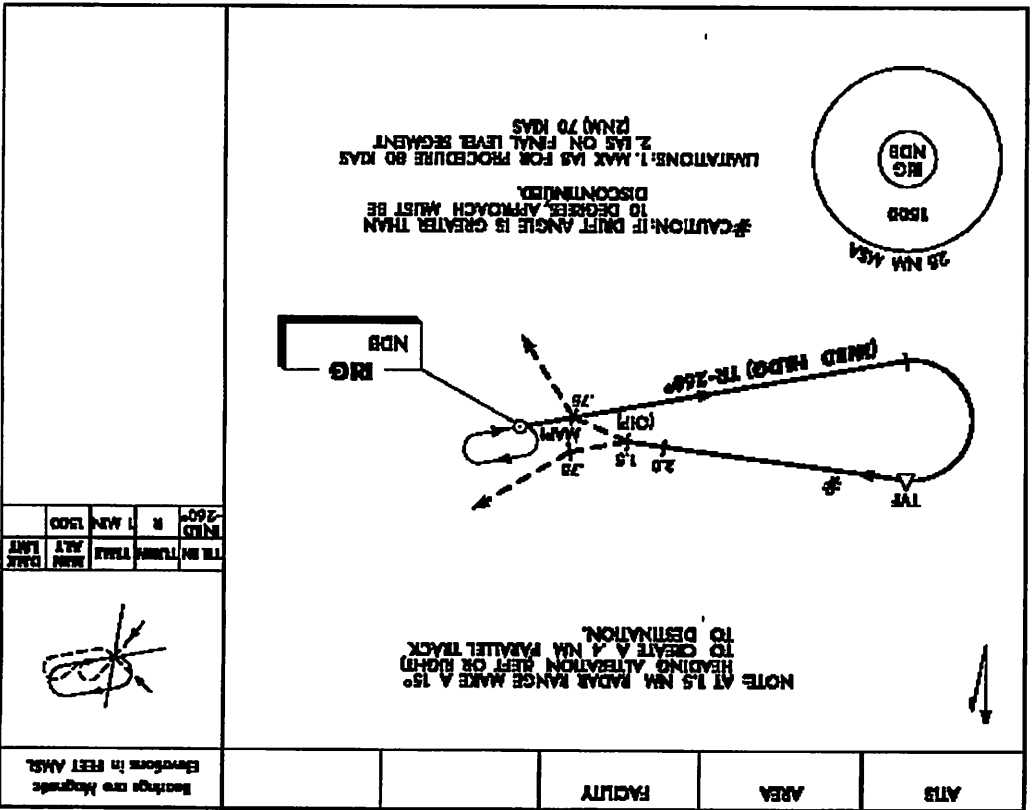
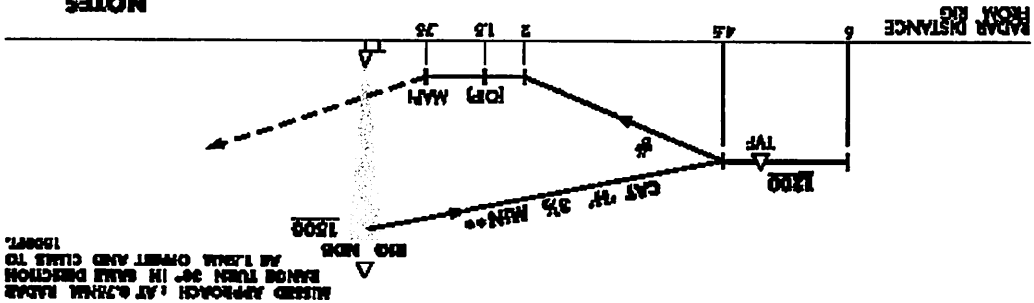

USE QNH

OFFSHORE RIG NDB-AIRBORNE RADAR APPROACH

Change New Procedure.

ATIS	AREA	FACILITY	Barometric Pressure
			Barometric Pressure

NOTE: AT 1.5 NM RADAR RANGE MAKE A 15° HEADING ALTERATION LEFT OR RIGHT TO CREATE A 4 NM PARALLEL TRACK TO DESTINATION.

CAUTION: IF DRIFT ANGLE IS GREATER THAN 10 DEGREE, APPROACH MUST BE DISCONTINUED.

LIMITATION: 1. MAX IAS FOR PROCEDURE 80 KIAS
 2. IAS ON FINAL LEVEL SEGMENT (IWL) 70 KIAS



TRK	TRK	TRK	TRK	TRK
1200	1050	890	730	570

SECTION 8.7: HELICOPTER OFF-SHORE PROCEDURES — NDB

8.7.1 Application

- 8.7.1.1 An Authorized designer may design procedures in accordance with this section provided that the platform is located 30 NM or more from the nearest land.
- 8.7.1.2 Procedures, at other sites (within 30 NM of land) must be designed by a certified designer.

8.7.2 Administration

- 8.7.2.1 Completed designs are forwarded to the relevant DGCA Area Office and to DGCA Airspace, Air Traffic and Aerodrome Standards Branch.
- 8.7.2.2 The DGCA Area Office is responsible for:
 - a. issuing designs to approved operators;
 - b. advising Airspace, Air Traffic and Aerodrome Standards Branch of those operators that have been issued with the procedure; and
 - c. forwarding to Airspace, Air Traffic and Aerodrome Standards Branch a copy of the relevant part of the approved operator's operations manual(s).
- 8.7.2.3 DGCA Airspace, Air Traffic and Aerodrome Standards Branch is responsible for:
 - a. maintaining a register of procedures; and
 - b. maintaining a register of operators who have been Authorized to use each procedure, and the associated company operations procedures.

8.7.3 Limitations Applying to Procedures Issued under this Standard.

- 8.7.3.1 The limitations applying to procedures issued under this standard are:
 - a. the landing pad must not be located closer than 30 NM to land;
 - b. the minimum altitudes shown in the attachment are valid provided that the landing pad is located on a vessel or structure carrying the NDB and that no configuration of this or any associated vessels or structure within 11 NM exceeds 200 ft above mean sea level (AMSL) without minima adjustment as detailed in paragraph 8.7.4;
 - c. the procedures may only be used with NDBs that have demonstrated suitable signal strength at 500 ft ASL to a range of 11 NM from the vessel over the entire 360°;

- d. the procedures may only be used with fixed structures, for example, oil rigs, if the minimum altitude accounts for rise and fall of the water (paragraph 8.7.4.2 refers);
- e. the intermediate segment times may not be increased without review of the 11 NM limitations.

Note:

Before attempting a procedure pilots must be in receipt of QNH data from a current and appropriate TAF or suitable ARFOR.

8.7.4 Minima Determination

8.7.4.1 **Values.** In determining minima, minimum altitudes must be rounded up to the nearest 10 ft and visibilities must be rounded up to the nearest half kilometre.

8.7.4.2 **Minimum Altitudes.** The minimum altitudes shown in the attachments must be increased if the landing pad vessel or its associated shipping within 11 NM of the landing pad exceeds 200 ft ASL or, if a fixed marine structure, 200 ft AMSL. The amount of increase in minimum altitude must be the amount by which the offending vessel or structure exceeds 200 ft. Further, the BARALT minimum must be factored to account for tidal rise and fall in excess of 10 ft when used with respect to sea-borne landing sites. Similarly, a RADALT minimum must be factored in relation to operations at installations that are fixed.

8.7.4.3 **Visibility.** Visibility is calculated in accordance with the formula in paragraph 8.7.6.

8.7.5 Assumptions Underlying these Procedures

8.7.5.1 The procedure and minima offered in the various sections of this manual make the following assumptions:

- a. local rise and fall does not exceed 10 ft;
- b. unknown shipping will not exceed 200 ft; and
- c. use of radio altimeter attracts a 100 ft concession to reduce pressure defined minimum altitudes.

8.7.6 Collision Avoidance Determination

Note:

Calculation of the minimum visual segment visibility is based on the CAR guidance to avoid obstacles by 600 m horizontally.

Data

CAR guidance	600 m
Obstacle recognition time	6 sec + 150 m
PANS-OPS bank establishment time	5 sec
Bank angle	The lesser of rate 1° or 25°
Wind	47 + 2H knots ($H = \frac{\text{altitude}}{1000}$)
TAS	Maximum TAS permitted at ISA + 15°

Calculation

Obstacle avoidance	= 600 m	= A
Turn radius (for calculation see PANS-OPS)		= B
Recognition and bank establishment		
11 x (TAS + 47 + 2H) + 150		= C
Turn point to obstacle distance	= $((A + B)^2 - B^2)^{1/2}$	= D
∴ Visibility required = C + D		

Figure 8-29: Offshore rig—NDB

OFFSHORE RIG		NDB	
RADAR DIST		NOT APPLICABLE	
ALT		NOT APPLICABLE	
AIP Authority			
CATEGORY	H	HELIOPTER USE ONLY	
LDG-BAR ALT	800* (500-2.0)		
LDG-RAD-ALT	450* (450-2.0)		
ALTERNATE	(1000-4.0)		

* MINIMA MUST BE INCREASED BY HEIGHT IN EXCESS OF 200 FT. OF ANY OBSTACLE WITHIN 11 NM.

NOTES

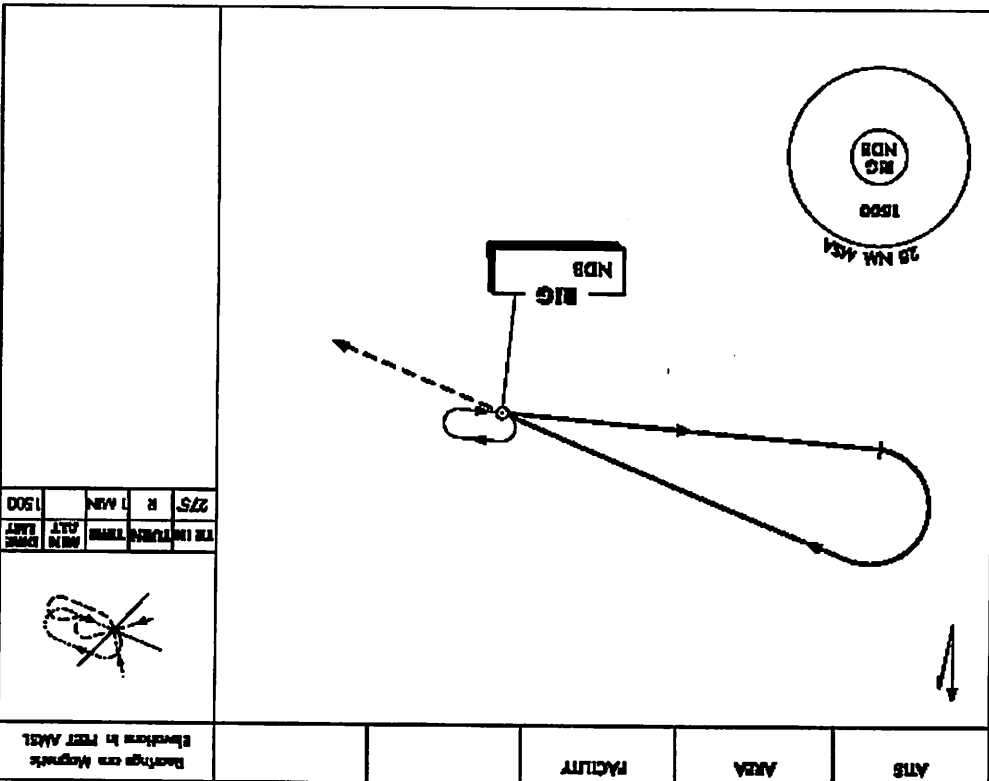
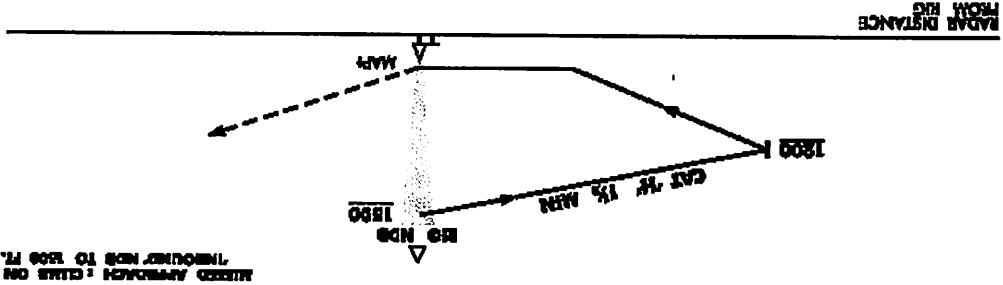

OFFSHORE RIG

USE QNH

Change New Procedures

8.7.7 NDB

SECTION 8.8: HELICOPTER PROCEDURES—GPS/NPAS

8.8.1 Application

- 8.8.1.1 An Authorized designer may design procedures in accordance with this section provided that the platform is located 30 NM or more from the nearest land.
- 8.8.1.2 Procedures at other sites (within 30 NM of land) must be designed by a certified designer.

8.8.2 Administration

- 8.8.2.1 Helicopter procedures under this section are classified as *specialized helicopter operations* and are not required to be given to the AIS for publication in the AIP
- 8.8.2.2 The use of these procedures is limited to approved operators.
- 8.8.2.3 Completed designs are forwarded to the relevant DGCA Area Office and to DGCA Airspace, Air Traffic and Aerodrome Standards Branch.
- 8.8.2.4 The DGCA Area Office is responsible for:
 - a. issuing designs to approved operators;
 - b. advising Airspace, Air Traffic and Aerodrome Standards Branch of those operators that are approved to use the procedure; and
 - c. forwarding to Airspace, Air Traffic and Aerodrome Standards Branch a copy of the relevant part of the approved operator's operations manual(s).
- 8.8.2.5 DGCA Airspace, Air Traffic and Aerodrome Standards Branch is responsible for:
 - a. maintaining a register of procedures; and
 - b. maintaining a register of operators who have been Authorized to use each procedure, and the associated company operations procedures.

8.8.3 Procedure Overview

- 8.8.3.1 All helicopter procedures designed under this section are to be designed in consultation with the local operator. Helicopter procedures are dependent upon visual segment procedures developed by the operator in consultation with the procedure designer. Operational procedures must include key visual features, hazards, routes to be flown and action to be taken in the event that meteorological conditions deteriorate below specified requirements and any other conditions relating to the procedure.

8.8.3.2 The operating procedures are to be included in the Operations Manual of an operator approved to use the procedure.

8.8.4 Visual Approach Area—Helicopter

8.8.4.1 Helicopter procedures will normally be designed with a Visual Approach Area - Helicopter (VAA-H).

8.8.4.2 Procedures that do not provide a VAA-H are to be noted accordingly on the approach chart.

8.8.4.3 The VAA-H criteria are based on the establishment of key visual lead-in features to the HLS. In this respect, each procedure will be unique and requires an operational specification to be included in an operator's operations manual.

8.8.4.4 The procedure designer must liaise with operators to define key lead-in features.

8.8.4.5 During validation, particular attention has to be considered for local operating procedures and key lead-in features.

8.8.4.6 This area is located between the MAPT and the HLS within which obstacle clearance at MDA is assured.

8.8.4.7 Operations within a VAA-H are visual flight manoeuvres. Once visual contact is established during the instrument approach, the helicopter is positioned within the VAA-H and manoeuvred utilising key lead-in points at altitudes not below the MDA until the HLS is sighted. (See AIP).

8.8.4.8 The missed approach criteria detailed in PANS-OPS Vol II Part III Chap 33 are also modified to take account of the VAA-H.

8.8.4.9 The centre of the HLS must be surveyed to an accuracy of 1/100th of a second of arc.

8.8.5 VAA-H Dimensions

8.8.5.1 **Area.** The VAA-H starts at the commencement of the missed approach segment with a width equal to the width of the final segment primary area at that point. Its boundaries join at a tangent to a circle of 926 m radius centered on the HLS (see Figure 8-30).

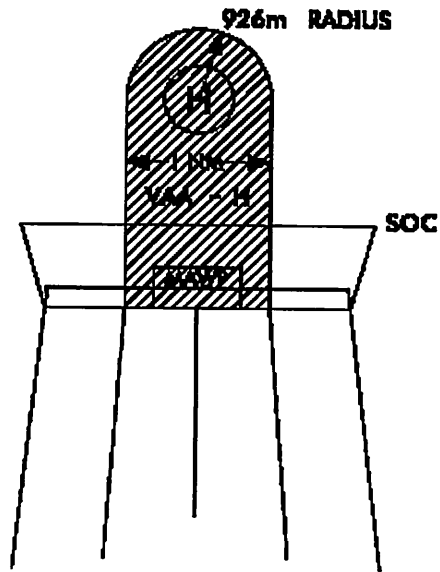

Figure 8-30: Visual approach area—helicopter

8.8.5.2 **Length.** The nominal length of the VAA-H is 3 km. The actual length is determined by the distance from the MAWP to the centre of the HLS. In any event, it should be such as to allow visual reference to be maintained with the HLS or key lead-in points.

8.8.6 **Obstacle Clearance**

8.8.6.1 A minimum obstacle clearance (MOC) of 90 m (295 ft) shall apply throughout the VAA-H. The principle of secondary areas does not apply.

8.8.7 **Missed Approach**

8.8.7.1 In addition to the standard missed approach analysis, a missed approach analysis for the VAA-H is also required. When considering these missed approaches, the obstacle distance (doH) is measured via the shortest distance from the boundary of the VAA-H or missed approach turn initiation area boundary (see Figure 8-31).

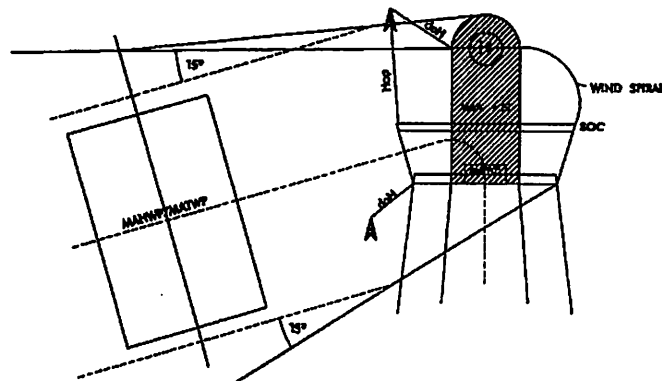

Figure 8-31: Turning missed approach

- 8.8.7.2 **Straight Missed Approach.** The VAA-H sits within the protected area of the straight missed approach segment. Accordingly, no adjustments are required for the straight missed approach splay (see Figure 8-32).

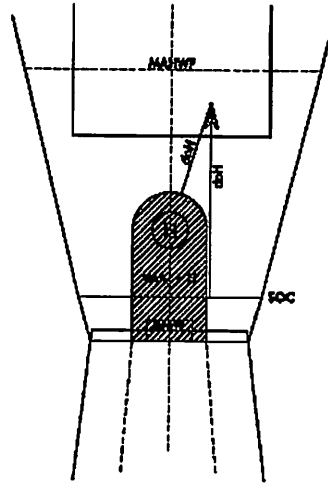

Figure 8-32: Straight missed approach

- 8.8.7.3 **Turning Missed Approach.** Depending on the turn angle, the VAA-H can extend beyond the protected area of the turning missed approach segment (see Figure 8-31) In this event, the turning missed approach area is extended on the outside of the turn by drawing a straight line from the outside edge of the splay at the nominal MAHWP or MATWP at a tangent to the 926 m radius arc around the HLS. The MOC in this extended area is 40 m (130 ft).

8.8.8 Calculation of MDA

- 8.8.8.1 The MDA for the procedure is the highest calculated OCA of the following the:
- final approach;
 - VAA-H;
 - missed approach;
 - VAA-H missed approach.

SECTION 8.9: PUBLISHING

8.9.1 Electronic Format

- 8.9.1.1 Procedures must be prepared in an electronic format acceptable to the publishing authority. The format must not permit alteration to the procedure by a person other than the designer.

8.9.2 Text Format

8.9.2.1 The following text formats must be used:

Notes:

1. Text in [] is optional and should be inserted only where the likelihood of confusion exists.
2. Text in {} should be inserted where required.
3. Text in () should be inserted as shown eg. in brackets.
4. 'ddd' = degrees in three digit format.
5. 'n' = number. (The number of 'n' indicates the minimum digits required.)
DME distances must be in whole or half miles with half miles normally shown as a fraction.
GPS distances are normally shown as a whole number or to one decimal place.
6. 'XXX' = Navigation aid ident.
7. 'YYYYY' = GPS waypoint.

(iii) **Distance (GPS)**

Plan	nn{n} YYYYY	From a designated waypoint
	nn{n}NM	From a Step down fix
Profile	nn{n} YYYYY	From a designated waypoint
	nn{n}NM	From a step down fix
Text	nn{n}NM YYYYY	From a designated waypoint
	nn{n} NM BEFORE YYYYY	From a step down fix

(iv) **Distance (NM)**

Plan	nn{n} NM
Profile	nn{n} NM
Text	nn{n} NM FROM XXX ARP

(v) **Time**

Time is expressed in whole or half minutes, followed by MIN eg.
3½ MIN

(b) **Aerodrome Charts**

(i) **Coordinates**

Grid	Degrees and minutes to one decimal place. Prefix with S or E, as appropriate (eg. S38 21.5)
ARP	Latitude and Longitude in degrees and minutes to one decimal place. Prefix with S or E, as appropriate (eg. S38 06.9 E147 09.9) <i>Derived or declared positions are suffixed with an asterisk.</i>

(ii) **Elevations**

Threshold	ELEV nn
All other elevations	Nn

(c) **Instrument Approach Charts**

(i) **Plan**

Grid	Degrees and minutes to one decimal place. Prefix with S or E, as appropriate (eg. S38 20.0)
------	--

(ii) **Holding Pattern**

NAVAID	Holding at {appropriate aid type} (eg. NDB)
Brg & Dist	Holding at XXX R-ddd/nn

(iii) **Profile**

Reversal Turns CAT BRG (TIME)
Where:
CAT — CAT A, or CAT A&B, or CAT A, B&C
BRG — ddd

TIME nn {½} MIN

THR Elevations THR nn ELEV nnn

(iv) **Missed Approach**

Straight TRACK ddd, CLIMB TO nnnn FT.

Turning TURN {LEFT or RIGHT}, TRACK ddd {XXX
R-ddd}, CLIMB TO nnnn FT.
*Additional text may be added to include turn height or
other requirements.*

(v) **GPS**

Distance/Altitude
scale and below
profile NM FM MAWP

Visual track from
MAWP to
Threshold Depicted as a series of dots on the profile
diagram. Note the final and visual track
should be a continuous line to 50 ft above
threshold.

Missed
Approach: TRACK DIRECT TO {MAHWP} THEN ddd,
CLIMB TO nnnn FT
*Additional text may be added to include turn height or
other requirements.*

(d) **Standard Instrument Departures**

(i) **Gradients**

Plan MINIMUM DESIGN CLIMB GRADIENT n.n%
to nnnn FT

Notes:

- 1. Where multiple gradients are shown on the chart the gradients are annotated against each appropriate leg and abbreviated as 'GRAD = n.n% to nnnn FT'. The following note must be included 'GRAD = MINIMUM DESIGN CLIMB GRADIENT'*
- 2. Where appropriate, supplementary gradients, based on airspace, are annotated in () behind the obstacle limited gradient.*

Text Where a gradient is greater than 3.3% it must be repeated at the start of the text description of the procedure. Where 'GRAD' has been used in the plan it may be used in the text description also

(ii) **Terminology**

The following terminology is used to complete the instruction set for the appropriate departure instructions:

Radar Departures

EXPECT RADAR VECTORS TO CLEARED ROUTE

Non-Radar Departures

TRACK TO [Waypoint name/Ident] THEN AS CLEARED

8.9.3 Drafting Conventions

8.9.3.1 Procedures must be drawn in accordance with the conventions shown on the following diagrams. Drafting conventions shown are applicable to Micro Station.

Figure 8-33: IAL legend (DAF 0-2)

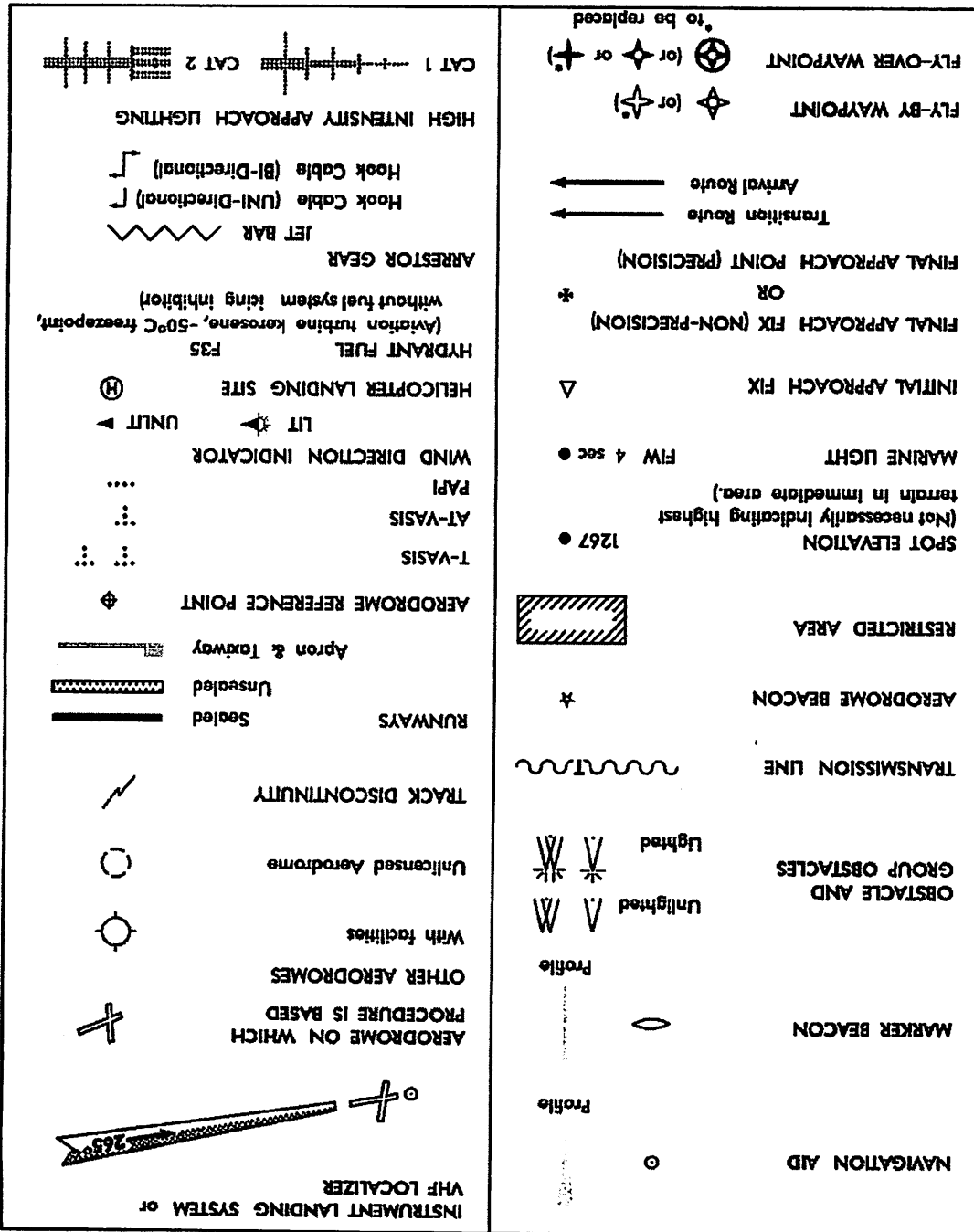

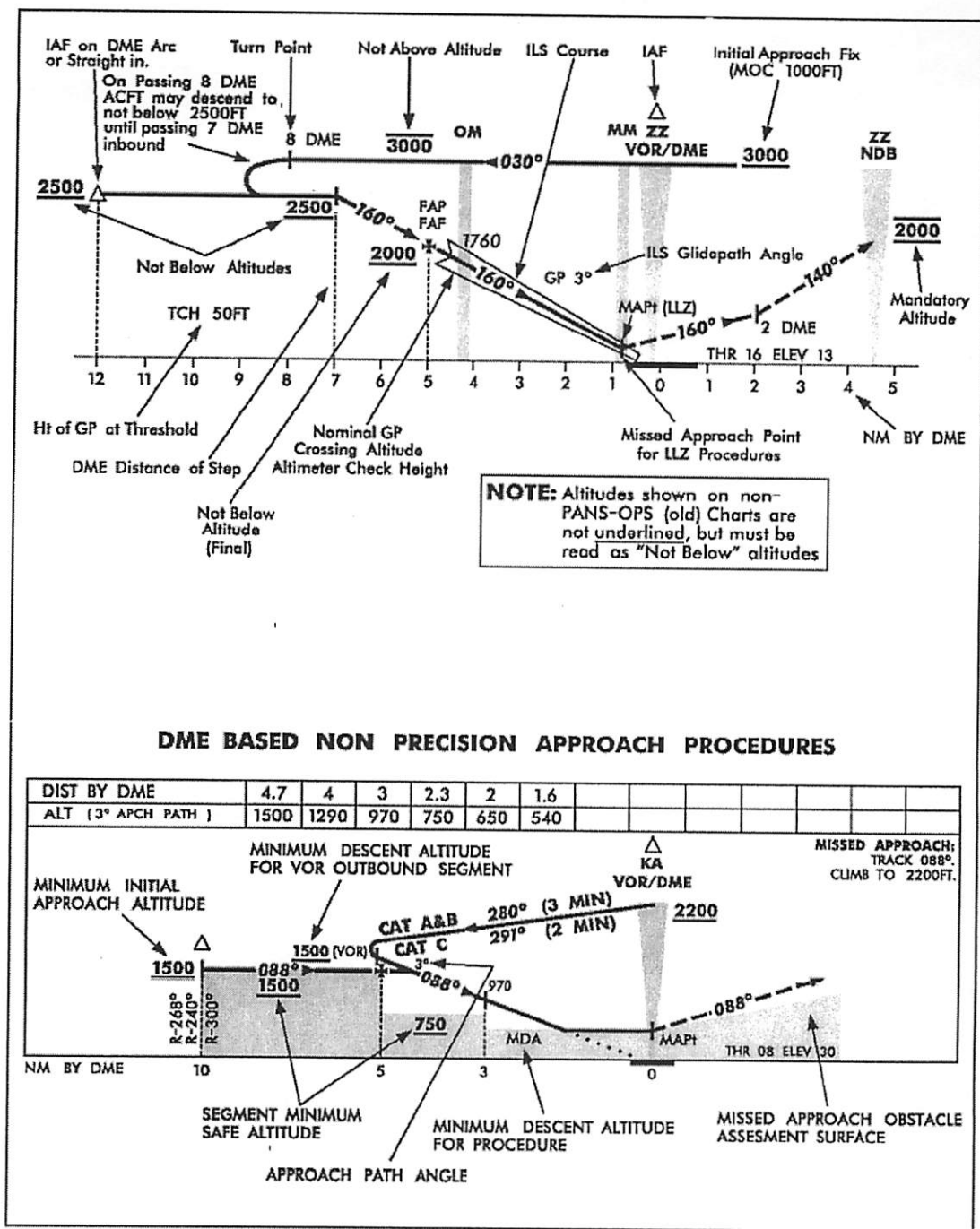

Figure 8-35: IAL legend (DAP 0-4)

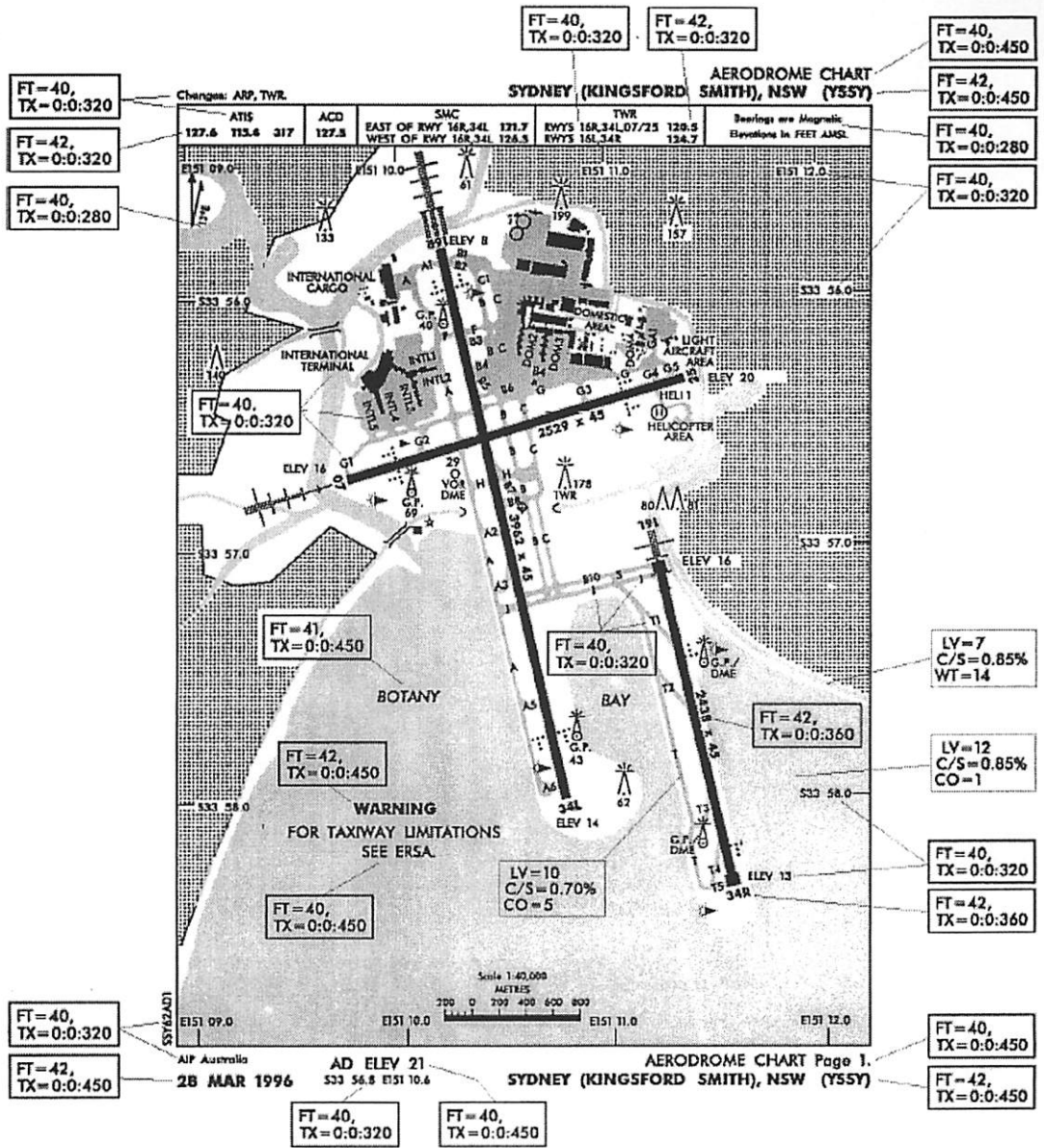

Figure 8-38: Aerodrome chart

DRAFT

CHAPTER 9: COMPUTATIONS

SECTION 9.1: VISIBILITY

9.1.1 Runway Approaches

9.1.1.1 The visibility for non-precision runway aligned approaches has been calculated to permit 160m of runway to be seen from an aircraft on a 3° approach gradient at the MDA.

9.1.1.2 In the case of precision approaches allowance is made for runway approach lighting to reduce the required visibility, and the design requirement is that 160 m of approach lighting can be seen at a point on glide slope at the DH.

9.1.1.3 At the MDA on a non-precision approach an aircraft may not be accurately aligned with the runway, (as can be expected in the case of a precision approach) and manoeuvring may be required to align the aircraft with the extended runway centre line. Therefore it is considered that where runway approach lighting is available, the required visibility should not be reduced.

9.1.1.4 Visibility can be calculated in accordance with the following formulae:

For precision approaches:

$$V \text{ (metres)} = 160m + \frac{(DH - TCH)m}{\tan 3^\circ} - APLL$$

Where APLL = Approach Lighting Length in metres

For non-precision approaches:

$$V \text{ (metres)} = 160m + \frac{(OCH - TCH)m}{\tan 3^\circ}$$

9.1.2 Circling Visibility

9.1.2.1 The basic circling visibility recognizes that the pilot must be able to see the runway from the downwind position. The value shall allow for an omnidirectional wind of 25 knots, an achieved bank angle of 25°, an OAT of ISA + 15, an altitude of aerodrome elevation plus 1000 ft and the average visual manoeuvring speed for category. Values must be determined using the following formula, however, an absolute minimum value of 2 km must be used.

$$V = 0.9D$$

Where V = circling visibility

D = diameter of turn at the average manoeuvring speed for category
0.9 = minimum downwind spacing to achieve alignment on final
approach.

CIRCLING VISIBILITY

Category	A	B	C	D
IAS (kt)	90.00	125.00	170.00	195.00
TAS (1000ft, ISA + 15)	93.70	130.14	176.99	203.01
r (km)	0.51	0.98	1.81	2.38
E(km)	0.21	0.29	0.39	0.45
D=2r +2E	1.43	2.54	4.41	5.67
0.9D	1.29	2.29	3.97	5.11
Min. Circling Visibility	2.00	2.40	4.00	5.00

DIRECTOR GENERAL OF CIVIL AVIATION

ttd

HERRY BAKTI

Salinan sesuai dengan aslinya

Kepala Bagian Hukum
Setditjen Hubud



RUD RICHARDO

D = diameter of turn at the average manoeuvring speed for category
 0.9 = minimum downwind spacing to achieve alignment on final
 approach.

CIRCLING VISIBILITY

Category	A	B	C	D
IAS (kt)	90.00	125.00	170.00	195.00
TAS (1000ft, ISA + 15)	93.70	130.14	176.99	203.01
r (km)	0.51	0.98	1.81	2.38
E(km)	0.21	0.29	0.39	0.45
D=2r +2E	1.43	2.54	4.41	5.67
0.9D	1.29	2.29	3.97	5.11
Min. Circling Visibility	2.00	2.40	4.00	5.00

DIRECTOR GENERAL OF CIVIL AVIATION



HERRY BAKTI

pd

D = diameter of turn at the average manoeuvring speed for category
 0.9 = minimum downwind spacing to achieve alignment on final
 approach.

CIRCLING VISIBILITY

Category	A	B	C	D
IAS (kt)	90.00	125.00	170.00	195.00
TAS (1000ft, ISA + 15)	93.70	130.14	176.99	203.01
r (km)	0.51	0.98	1.81	2.38
E(km)	0.21	0.29	0.39	0.45
D=2r +2E	1.43	2.54	4.41	5.67
0.9D	1.29	2.29	3.97	5.11
Min. Circling Visibility	2.00	2.40	4.00	5.00

DIRECTOR GENERAL OF CIVIL AVIATION



HERRY BAKTI