

Design and Fabrication of an Automatic Cloth Ironing Machine

Nur Akmal Haniffah^{a,b*}, Mohamad Amirul Hamka Azima^a & Sabariah Julaihi^b

^a*Department of Mechanical Engineering, Faculty of Engineering,
Universiti Pertahanan Nasional Malaysia, Malaysia*

^b*Department of Mechanical Engineering, Faculty of Engineering,
Universiti Malaya, Malaysia*

*Corresponding author: nurakmal@upnm.edu.my

Received 30 April 2024, Received in revised form 15 October 2024
 Accepted 8 November 2024, Available online 30 January 2025

ABSTRACT

General automation in household chores uses technology and devices to carry out conveniently or aid in completing ordinary domestic duties, enhancing daily living. However, the traditional method of ironing clothes is one of the everyday tasks around the house that has been waiting for a revolution for a long time. The ironing task is still done by hand and is not automated. The problem is that ironing excessive clothes, especially school uniforms, for a week's usage can be laborious and time-consuming. Anyone would experience boredom, tiredness and fatigue due to this circumstance when ironing continually. Therefore, to solve the issue, this project was developed to eliminate the tedious ironing process. This project aims to develop an automatic cloth ironing machine using a few low-cost electronic and mechanical components and compare the timing of cloth ironing using an automatic machine and by hand. As a result, a prototype presented a revolutionary initiative that combines modern technology and automation to revolutionise traditional clothing ironing methods. It can respond to specific fabric types and sizes, ensuring consistency in the ironing process. In conclusion, a prototype was successfully designed and developed with various low-cost electronic components and mechanical devices, e.g. an Ultrasonic Sensor HC-SR04, Arduino UNO, a belting system and a steam generator. Then, using the machine is slightly slower by 40 seconds compared to ironing manually. This achievement reassures the potential of the machine. Future development plans include using two steam plates to iron the back and front of the clothes and using a steam generator with a higher power that produces much steam.

Keywords: Ironing; ultrasonic sensor; arduino; belting system; steam generator

INTRODUCTION

Household tasks are essential and among the most time-consuming activities. This task is carried out daily and is incomplete when home chores are neglected (Deng et al. 2019). Various humanly operated equipment is gradually being abandoned in favour of fully automatic equipment, resulting in automatic equipment dominating human existence (Miller et al. 2011). Hence, automation in household chores can reduce time and make tasks more efficient. Home automation has been a thing for many years with the introduction of numerous large appliances on the market (Ko & Eshraghi 2023). For example, daily laundry tasks are easier to manage with the help of washer and dryer machines (Haniffah et al. 2025).

However, traditional ironing methods are still time-consuming and require expertise. School uniforms require ironing, and students are expected to wear multiple uniforms daily. Parents often prepare clothes weekly, but excessive ironing can lead to boredom, tiredness, and fatigue (Bashir & Tuljapure 2019). The time required for properly ironing a shirt depends on experience, with amateurs taking 10-15 minutes and experts taking 3-5 minutes. Ironing can also cause strain on the shoulder, neck and upper back due to prolonged standing, excessive bending and repetitive motion (Fatima et al. 2023).

A few products on the market are related to automatic ironing machines. With two engineers based in London, Rohan and Trevor, the startup plans to tackle the daily grind of housewives with its self-titled gadget, Effie, as shown

in Figure 1. The £699 (about RM 4076.15) Effie can automatically press and de-wrinkle up to 12 garments

simultaneously. This machine is too expensive for ordinary people and can be used only by the rich and able.



FIGURE 1. Effie Automatic Ironing Machine (Bennett 2017)

Besides, YAC Japan Automatic Ironing Machine presents their all-new, automated ironing machine that can press up to 120 shirts in an hour and is powered by clean solar energy. With this super-efficient design, YAC Japan strives to improve productivity and profitability for professionals working in the industry. This machine is too big to be placed in a room or a house. So, it is not suitable for use by housewives and placed at home (Lynne 2021).

Thus, Arduino is widely used in medicine, agriculture, traffic monitoring, robotics, and automation (Sudianto et al. 2023).

An Arduino is a circuit board programmed to do various tasks today, where programming is commonly utilised. The purpose of Arduino is to execute code within the Arduino Integrated Development Environment (IDE) and provide communication between input and output sensors (Nathan et al. 2023). Despite its simplicity and modest cost, the Arduino can act as a competent microcontroller for experimentation scenarios (Schubert et al. 2013). The duration and latency of the signal produced by an Arduino were regularly constant (D’Ausilio 2012).

Self-ironing machines are in increasing demand in our daily lives. Therefore, the objectives of this project are to develop an automatic cloth ironing machine using low-cost electronic and mechanical components and compare the timing of cloth ironing using an automatic machine and by hand.

METHODOLOGY

This project’s background study is based on the literature review of ultrasonic sensors, Arduino, steam generators, and belt pulleys. The function structure diagram (FSD), which divides the primary product into more minor, easier-to-manage challenges, is invaluable for providing detailed descriptions of product functions.

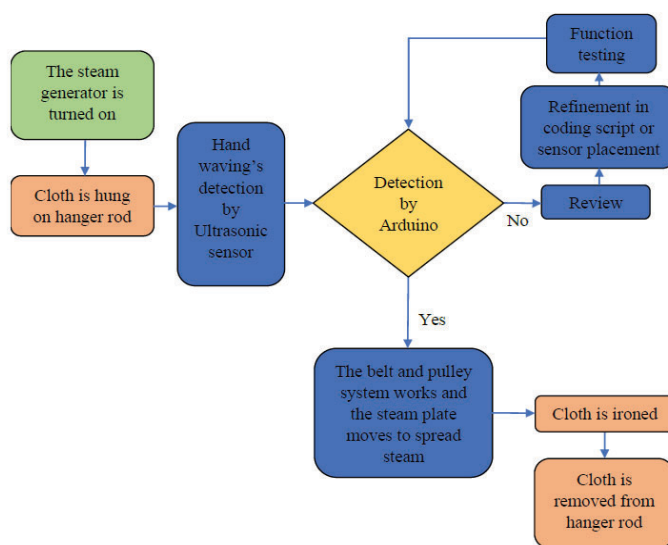

FIGURE 2. Function Structure Diagram

The functions of the entire product, subassemblies, and individual components are divided into several categories better to understand the automatic cloth ironing machine's functioning. Figure 2 shows a function structure diagram, enabling an in-depth look at the device's functions and relationships.

CHALLENGES AND POTENTIAL DIFFICULTIES OF THE PRODUCT

The product was expected to encounter specific difficulties while used for ironing purposes. As a result, seven presumptive difficulties were identified, and a recommended method for resolving them was determined, as shown in Table 1.

TABLE 1. Challenges and potential difficulties for an ironing cloth machine

Challenges / Difficulties	Effect on product	Propose solution
Steam does not come out much.	The fabric is still wrinkled.	Use a steam generator that can produce steam.
Clothes come in all sizes and shapes.	Making it difficult to ensure complete and uniform ironing.	Make a plate steam generator that moves from top to bottom as much as possible.
Materials are not resistant to high temperatures.	The material will melt.	Use high-quality materials like Mild Steel and Galvanized Iron.
Ultrasonic sensor does not detect hand waves.	The machine system is not working automatically.	Place the ultrasonic sensor in a place that makes it easy to detect the hand wave.
The machine is overheated.	The safety of users, especially in households with children or pets, will be affected.	Implement safety features such as automatic shut-off in case of malfunctions, temperature sensors to prevent overheating, and physical barriers to prevent accidental contact with hot surfaces.
Difficult to repair when damaged.	May experience damage to components over time.	Design components for easy replacement and provide users with regular maintenance guidelines. Incorporate self-diagnostic features to alert users to potential issues.
The user does not know how to turn on the machine.	Difficult to operate the machine.	Develop a simple and intuitive user interface with customisable settings. Incorporate LCD for easy control and monitoring.

PRODUCT DESIGN SPECIFICATIONS (PDS)

A product design specification (PDS) is a product requirement. It provides all the product information with

specific features and functionalities and offers a technical description, performance specification, technical standards to meet, and other details. The PDS is based on the general requirement, as shown in Table 2.

TABLE 2. Product Design Specifications (PDS)

General Requirement	Specific Requirement	Acceptance Performance
Automatic	Auto-ironing the cloth	-Using Arduino Uno to generate the steam generator, moveable steam plate and other electronic devices. -Sensors to drive all machine work movements
Safety	The structure of the machine does not harm the user	-All electronic compartments are covered -users do not be exposed to steam heat
Quality	-Ironing in a good condition -Easy to use	-Remove wrinkles on clothes -Place the cloth in the machine, and it will iron automatically
Dimension	-Easy to move the machine -Easy to store -Suitable for different sizes of clothes	-Using a simple wheel with a stopper -Length: 60 cm -Width: 50 cm -Height: 150 cm

CONCEPTUAL DESIGN

Design concept generation entails creating many goods to investigate product design specifications. This procedure begins with client criteria and concludes with several concept design possibilities to select a final design. Several concept sketches were drawn on A4 paper by hand using a pencil. The features and mechanisms will be described in great depth. In this project, four design concepts were created and compared to find the most satisfactory product. Figure 3 shows four sketches of four concepts for an ironing device.

Figure 3(a) shows that design concept 1 has a steam plate driven by a belt and pulley. The steam plate moves vertically from bottom to top or vice versa several times to apply steam to the hanging clothes. The ultrasonic sensor instructs the Arduino to turn on the machine when the clothes are hung on the hanger rod at the top. The steam generator is combined outside the machine, and all electronic components are on top of the steam generator to facilitate maintenance work. All electronic components, steam generator and ironing space are covered to avoid accidents and damage. A steam chimney is placed in the corner of the top of the machine to remove excess steam. Wheels with stoppers are also used to move the machine easier.

Besides, based on Figure 3(b), this sketch provides the neatest design because the steam generator is placed under the ironing space. When the user hangs the clothes on the hanger rod, the ultrasonic sensor detects the clothes and instructs the Arduino to turn on the machine. To distribute steam to the hanging clothes, the steam plate, driven by a belt and pulley, moves repeatedly from bottom

to top. All the electronic components are safe in the box on top of the machine so that it is not exposed to children and pets. A steam chimney is placed in the corner of the top of the machine to remove excess steam. Wheels with stoppers are also used to move the machine easier.

Based on Figure 3(c), this design is the same as design concept 2, but it only uses one steam plate, and it looks easier to use because the electronic components are on the side of the machine. With that, the LCD and the control devices are at the same level as the user, which can also facilitate maintenance work. The steam generator is placed under the ironing space. The ultrasonic sensor instructs the Arduino to turn on the machine when the clothes are hung on the hanger rod at the top. The steam plate, moved frequently from bottom to top by a belt and pulley, delivers steam to the hanging clothing. A steam chimney is placed in the corner of the top of the machine to remove excess steam. Wheels with stoppers are also used to to move the machine easier.

Morover, based on Figure 3(d), design concept 4 differs from other designs. The uniqueness of this design is that the door is pulled out of the machine by sliding. The clothes hanger rod is pulled once with the door for the clothes hanging process. The steam plate moves from bottom to top several times to apply steam to the hanging clothes. The ultrasonic sensor instructs the Arduino to turn on the machine when the clothes are hung on the hanger rod at the top. All the electronic components are safe in the box on top of the machine so that it is not exposed to children and pets. A steam chimney is placed at the top of the machine to remove excess steam. Wheels with stoppers are also used to move the machine easier.

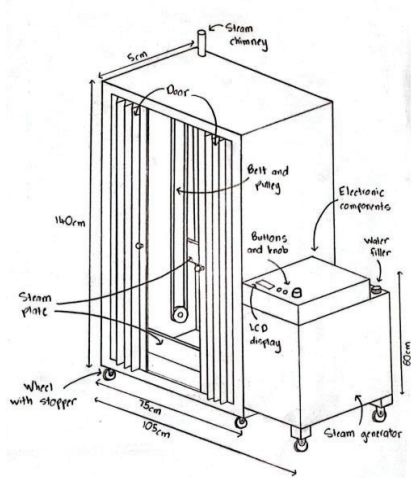

(a) Design 1

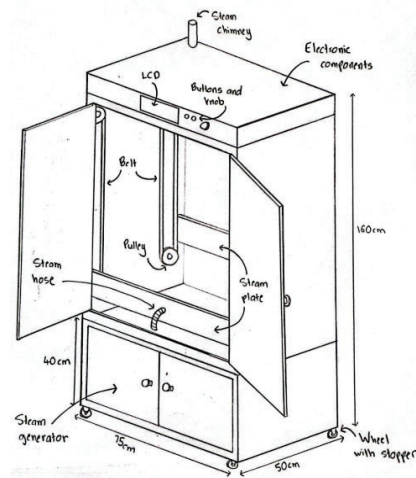

(b) Design 2

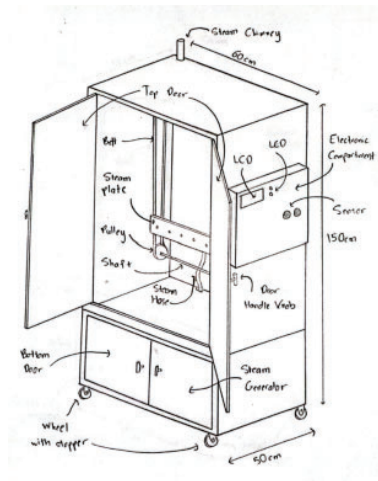

(c) Design 3

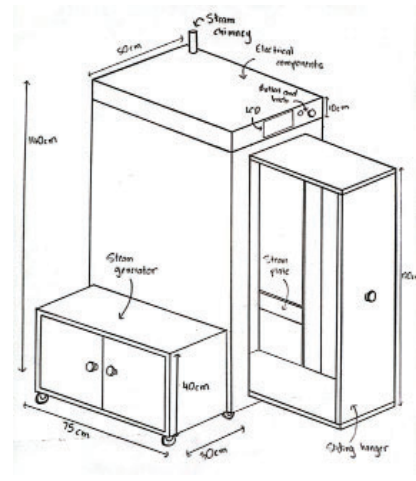

(d) Design 4

FIGURE 3. Sketch of four concepts for an ironing machine

CONCEPT EVALUATION

All four design concepts were analysed and screened to develop a final design concept. Each design concept was run through the Pugh design concept selection table in the first step. Based on comparing the current ironing device (Figure 1) with the product design specification, some

features were identified, and scores were given, as shown in Table 3. A score of (-) is given to the designs that do not satisfy the criteria by the potential user, while (+) is given to the designs that meet advanced standards, and (0) is allocated to the designs that follow the reference. Add all of the (0), (+), and (-) to get a net score for each design concept. The top two design ideas with the highest net score will move on to the next phase of the screening.

TABLE 3 Pugh design concept selection for 4 designs

Features	Design Concept Variation				
	Design 1	Design 2	Design 3	Design 4	Reference
Effectiveness of Mechanism	0	0	0	0	0
Capacity	+	+	+	0	+
Safety	-	+	+	+	+
Weight	0	0	0	0	0
Cost	0	0	0	0	-
Maintenance	+	-	+	-	0
Storage Space	-	+	+	-	0
Plus	2	3	4	1	
Same	3	3	3	4	
Minus	2	1	0	2	
Nett	0	2	4	-1	
Rank	4	2	1	5	
Continue?	NO	YES	YES	NO	

TABLE 4 Weight Decision Matrix for two designs

Criteria	Concepts				
	Design 2		Design 3		
	Weight (%)	Rating	Weightage Score	Rating	Weightage Score
Safety	20	4	0.80	4	0.80
Capacity	20	4	0.80	4	0.80

continue ...

... cont.

Effectiveness of Mechanism	15	5	0.75	5	0.75
Maintenance	15	2	0.30	5	0.75
Cost	15	4	0.60	4	0.60
Storage Space	10	4	0.40	3	0.30
Weight	5	4	0.20	4	0.20
Total Score		27	3.85	29	4.20
Rank			2		1
Continue?			NO		YES

WEIGHT DECISION MATRIX

RESULTS AND DISCUSSION

The two design concepts that passed the first screening stage were subjected to the second stage to determine which product would be produced in this project. The design ideas that passed the previous screening are Design 2 and Design 3. A Weighted Decision Matrix was used in the next screening, as shown in Table 4. Each design concept is given points based on the selection criteria. Before that, a score of 1 to 5 is assigned to each of the seven qualities used in the selection criterion. All of these categories are defined. Each unique design concept is rated, and scores are awarded to the design ideas. Each criterion is awarded 100% based on its importance. The rate allocated to each of the seven design ideas compounds this percentage weighting.

The cloth ironing machine may be described as an automatic machine in which an Arduino acts as the brain and other electronic components such as an ultrasonic sensor, LCD Display and DC motors. The selected design has been made into a 3D drawing using CAD tools, namely SolidWorks software. Figure 4 shows the final design of an automatic cloth ironing machine.

The prototype for this project was produced by combining all the parts created and purchased separately. Many fabrication methods produce prototypes, such as welding, grinding, plate cutting, and connecting components. Figure 5 shows the complete prototype assembly.

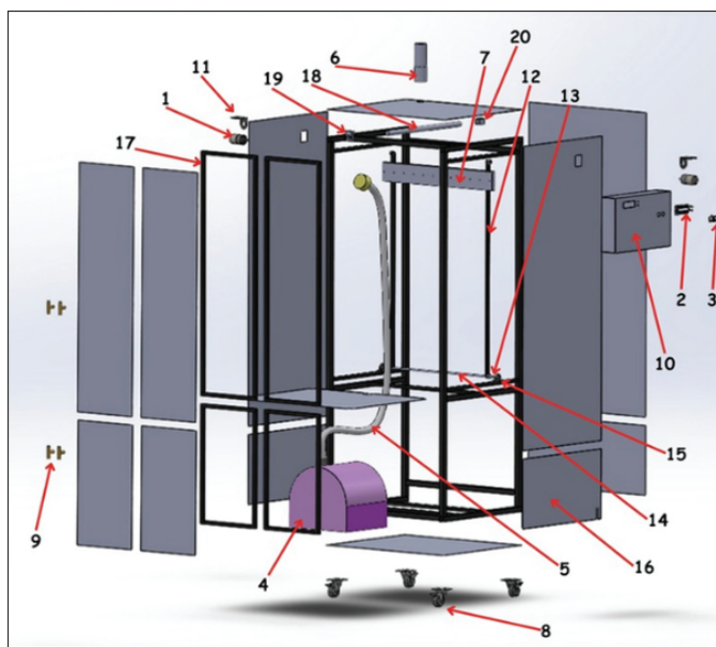

No	Description	Quantity
1	DC Motor	2
2	LCD Display	1
3	Ultrasonic sensor	1
4	Steam Generator	1
5	Steam Hose	1
6	Steam Chimney	1
7	Steam Plate	1
8	Wheel with Stopper	4
9	Door Handle	4
10	Electronic Compartment	1
11	DC Motor Bracket	2
12	Belt	2
13	6mm Pulley	4
14	6mm Shaft	1
15	KP08 Bearing	2
16	Galvanized Iron Plate	13
17	Square Hollow Mild Steel	37
18	Hanger Rod	1
19	Hanger Rod Holder	1
20	Hanger Rod Bracket	1

FIGURE 4. Exploded view of an Automatic Cloth Ironing Machine by Solidworks

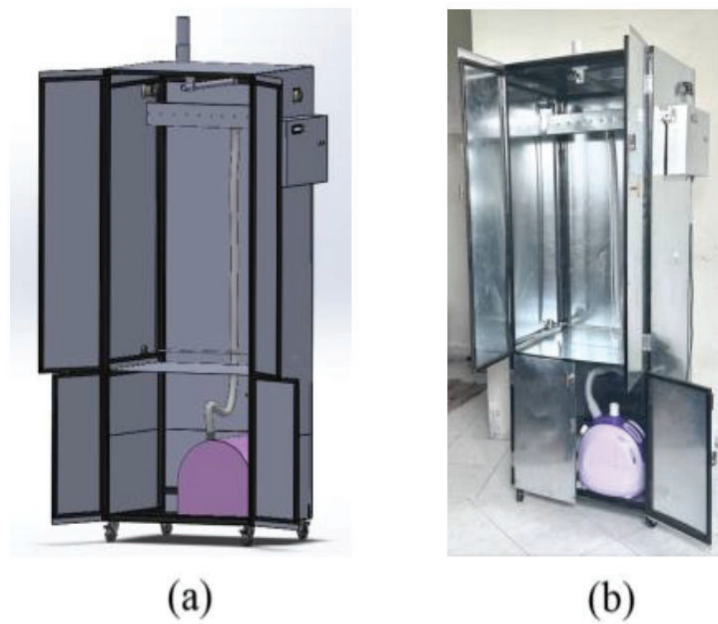
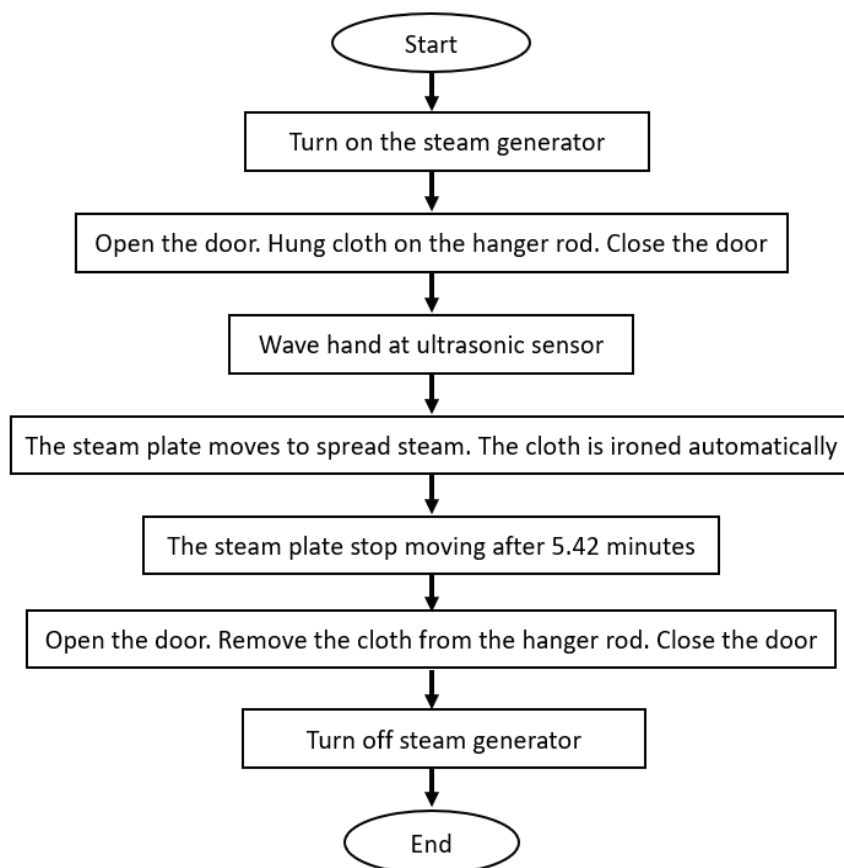

FIGURE 5. Prototype of an automatic cloth ironing machine



FIGUREw 6. Flow Chart of Ironing Process

While developing this prototype, two DC motors were used to move the belt parts, causing the steam plate to move repeatedly from top to bottom and up again to spread steam on the clothes. A jumper wire connects this DC motor to the Arduino Uno controller. The DC motor has positive and negative cables. Programming to control the DC motor’s movement is included in the Arduino.

This machine has undergone various validations, such as validating Arduino L293D DC motor driver control. An Arduino L293D DC Motor Driver Control assists with the two DC motors. The L293D is a dual-channel integrated circuit (IC) motor driver that can drive one stepper motor and two DC motors with bidirectional control. The L293D devices are half-H drivers with quadruple high current. Up to 600 mA of bidirectional drive current can be achieved with the L293D at voltages ranging from 4.5 V to 36 V. Besides, HC-SR04 ultrasonic sensor use a set programme to perform their duties. The 40 kHz sound waves that the ultrasonic sensor emits travel through the air, picking up on any objects or obstacles that come in their path. Once sent there, it returns to the module. Consequently, the Arduino receives the data when the hand is waved over the sensor, enabling the prototype to start working.

There are various steps in the validation process for an automatic cloth ironing machine to ensure the LEDs live up to the necessary reliability, safety, and performance standards. The LEDs undergo mechanical and electrical testing to ensure they work within the designated voltage and current ranges. Verification of control systems and compatibility and performance are ensured through integration testing. The validation process guarantees the ironing machine’s longevity and dependability, ensuring

the LEDs meet the necessary standards. A steam generator produces steam and connects it to the steam plate using a hose. For the validation process, the steam iron is turned on as usual by turning the knob. It takes 60 seconds to start generating steam. Steam exits through the vertical hose and the steam plate. Referring to the function structure diagram in Figure 2, the user needs to take only a few steps to use the automatic ironing machine, as shown in Figure 6.

The second objective is to compare the timing of the use of automatic and manual cloth ironing machines. Ironing small amounts of cloth by hand is typically quicker and more accessible, but the quality depends on the ironer’s neatness. However, large amounts of cloth to iron can wear out the ironers, resulting in less neat ironing. Consequently, while maintaining the same level of ironing throughout the process, assistive technology like the Automatic Cloth Ironing Machine can help lessen fatigue.

Figure 6 shows that the time required to iron one cloth with an automatic cloth ironing machine was 5 minutes 42 seconds, which remains constant even when ironing the tenth cloth. However, the time required to iron clothes by hand increases from 3 minutes 58 seconds (first cloth) to 6 minutes 5 seconds (tenth cloth) due to human factors like boredom, fatigue, and tiredness. The machine can iron cloth consistently and prevent users from getting tired from ironing manually. Based on the results, using the machine is slightly slower by 40 seconds compared to ironing manually. This is calculated through the average time of 5 minutes 42 seconds and manual (machine) versus 5 minutes 2 seconds (manual).

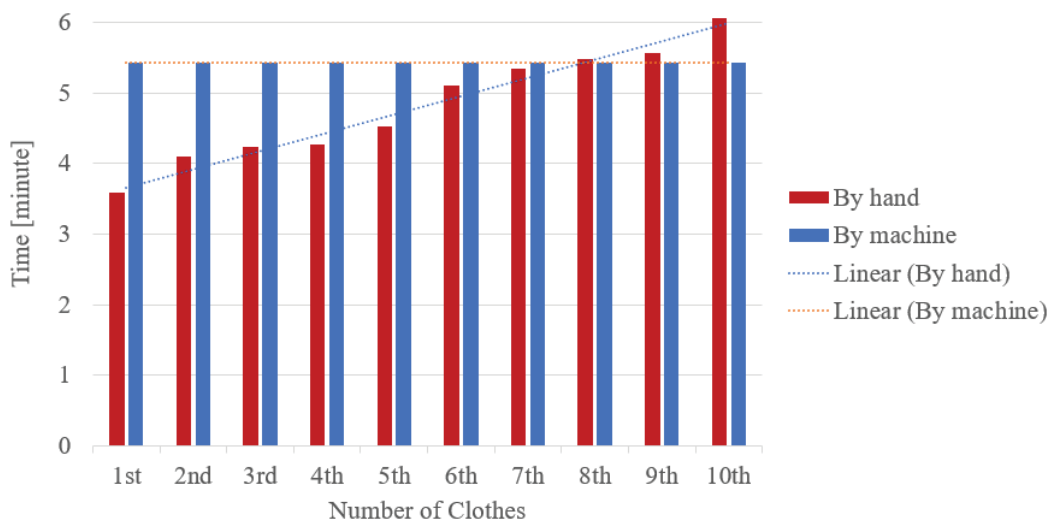

FIGURE 7. Ironing Time Comparison between by Hand and by Automatic Cloth Ironing Machine

CONCLUSION

In conclusion, objective 1 was successfully achieved as a prototype was developed using various low-cost electronic and mechanical components: an HC-SR04 ultrasonic sensor, an Arduino UNO, DC motors, pulleys, belts, and steam generators. Besides, for objective 2, by comparing the timing of ironing, utilising the machine takes around 40 seconds longer than manually ironing. The machine can iron the shirt consistently, but ironing manually will cause the ironing time to grow more due to boredom, tiredness and fatigue. The project addresses issues like machine adaptability, steam generator insufficient steam production, and potential safety hazards in this machine. Since this machine was the first prototype, it offers potential for future development, including dual-steam plate systems, high-power steam generators, and an emergency stop button.

ACKNOWLEDGEMENT

This research was funded by the Faculty of Engineering, Universiti Pertahanan Nasional Malaysia.

DECLARATION OF COMPETING INTEREST

None.

REFERENCES

- Bashir, S. A. M. A., & Tuljapure, S. 2019. Design of low cost semi-automatic dry ironing machine for laundries. *International Journal of Mechanical and Production Eng Research and Development* 9(5): 113-124.
- Bennett, B. 2017. Effie robot claims to do all your ironing. CNET.
- D'Ausilio, A. 2012. Arduino: A low-cost multipurpose lab equipment. *Behavior Research Methods* 44(2): 305–313.
- Deng, E., Mutlu, B., & Mataric, M. J. 2019. Embodiment in socially interactive robots. *Foundations and Trends® in Robotics* 7(4): 251-356.
- Fatima, A., Zaheer, A., & Rowson, J. 2023. Evaluating and managing MSDs in domestic tasks through ergonomics. *Journal of Engineering Research* 11(1B).
- Haniffah, N. A., Kamal, M. S. M., & Hasbi, S. 2025. Design and fabrication of a simple device for folding towel. *Journal of Advanced Research in Applied Sciences and Engineering Technology* 44(2): 221-233.
- Ko, H. S., & Eshraghi, S. 2023. *Automation in Home Appliances Springer Handbook of Automation* (pp. 1311-1330): Springer.
- Lynne, M. 2021. Iron 120 shirts per hour with YAC japan's fully automated ironing machine. *Designboom: Architecture & Design Magazine*.
- Miller, S., Fritz, M., Darrell, T., & Abbeel, P. 2011, May. Parametrised shape models for clothing. In 2011 IEEE International Conference on Robotics and Automation (pp. 4861-4868). IEEE.
- Nathan, S. S., Ying, K. J., Wen, L. H., & Weoi, L. X. 2023. Design of smart walking shoe for visually impaired people. *Journal of Advanced Research in Applied Mechanics* 101(1): 53-61.
- Schubert, T. W., D'Ausilio, A., & Canto, R. 2013. Using Arduino microcontroller boards to measure response latencies. *Behavior Research Methods* 45(4): 1332–1346.
- Sudianto, A., Jamaludin, Z., Rahman, A. A. A., Muharrom, F., & Novianto, S. 2020. Smart temperature measurement system for milling process application based on mlx90614 infrared thermometer sensor with Arduino. *Journal of Advanced Research in Applied Mechanics* 72(1): 10-24.