

## Optimal Adaptive Neuro-Fuzzy Inference System Architecture for Time Series Forecasting with Calendar Effect

(Seni Bina Sistem Inferens Neuro-Kabur Adaptif Optimum untuk Ramalan Siri Masa dengan Kesan Kalendar)

PUTRIAJI HENDIKAWATI<sup>1,2,\*</sup>, SUBANAR<sup>1</sup>, ABDURAKHMAN<sup>1</sup> & TARNO<sup>3</sup>

<sup>1</sup>*Department of Mathematics, Gadjah Mada University, Yogyakarta, Indonesia*

<sup>2</sup>*Department of Mathematics, Universitas Negeri Semarang, Semarang, Indonesia*

<sup>3</sup>*Department of Statistics, Universitas Diponegoro, Semarang, Indonesia*

*Received: 19 January 2021/Accepted: 13 August 2021*

### ABSTRACT

This paper discusses a procedure for model selection in ANFIS for time series forecasting with a calendar effect. Calendar effect is different from the usual trend and seasonal effects. Therefore, when it occurs, it will affect economic activity during that period and create new patterns that will result in inaccurate forecasts for decision making if not considered. The focus is on the model selection strategy to find the appropriate input variable and the number of membership functions (MFs) based on the Lagrange Multiplier (LM) test. The ARIMAX stochastic model is used at the preprocessing stage to capture calendar variations in the data. The calendar effect observed is the Eid al-Fitr holiday in Indonesia, a country with the largest Muslim population in the world. The data of Tanjung Priok port passengers used as a case study. The result shows that hybrid ARIMAX-ANFIS based on the LM test can be an effective procedure for model selection in ANFIS for time series with calendar effect forecasting. Empirical results show that the use of the calendar effect variable provides more accurate predictions as indicated by smaller RMSE and MAPE values than without the calendar effect variable.

Keywords: ANFIS; ARIMAX; calendar effect; LM test; time series

### ABSTRAK

Kertas ini membincangkan prosedur pemilihan model ANFIS untuk peramalan siri masa dengan kesan kalendar. Kesan kalendar berbeza daripada aliran biasa dan kesan bermusim. Oleh itu, apabila ia berlaku, ia akan menjejaskan aktiviti ekonomi dalam tempoh tersebut dan mewujudkan corak baharu yang akan mengakibatkan ramalan yang tidak tepat untuk membuat keputusan jika tidak dipertimbangkan. Fokus adalah pada strategi pemilihan model untuk mencari pemboleh ubah input yang sesuai dan bilangan fungsi keahlian (MF) berdasarkan ujian Pengganda Lagrange (LM). Model stokastik ARIMAX digunakan pada peringkat prapemprosesan untuk mengesan variasi kalendar dalam data. Kesan kalendar yang diperhatikan ialah cuti Hari Raya Aidilfitri di Indonesia, sebuah negara dengan penduduk Islam terbesar di dunia. Data penumpang pelabuhan Tanjung Priok digunakan sebagai kajian kes. Keputusan menunjukkan bahawa ARIMAX-ANFIS hibrid berdasarkan ujian LM boleh menjadi prosedur yang berkesan untuk pemilihan model dalam ANFIS dalam siri masa dengan ramalan kesan kalendar. Keputusan empirik menunjukkan bahawa penggunaan pemboleh ubah kesan kalendar memberikan ramalan yang lebih tepat seperti yang ditunjukkan oleh nilai RMSE dan MAPE yang lebih kecil berbanding tanpa pemboleh ubah kesan kalendar.

Kata kunci: ANFIS; ARIMAX; kesan kalendar; siri masa; ujian LM

### INTRODUCTION

In recent times, the development of forecasting methods has been widely used and benefits various fields. The use of nonlinear models with the help of machine learning

for forecasts has also been widely studied. Adaptive Neuro-Fuzzy Inference System (ANFIS) combines two soft computing methods, namely ANN and fuzzy logic (Jang 1993). In ANFIS, the fuzzy inference system is

implemented in the adaptive network framework. ANFIS has several advantages: a high convergence rate, good stability, a repeatable training process, high prediction precision, and very suitable for dealing with time series prediction problems (Liu & Zhou 2017). There have been many studies related to the advantages of ANFIS for prediction and forecasting, among them Duan et al. (2019), Lei and Wan (2012), Nayak et al. (2004), Sumithira and Nirmal (2014), and Wei et al. (2011). The development of ANFIS with various other methods that produce hybrid methods to get better results has also been studied by Gunasekaran and Ramaswami (2014), Liu and Zhou (2017), and Sood et al. (2020). In addition, several studies on hybrid models, including Kamisan et al. (2018) and Suhartono et al. (2019), also show that the hybrid model can give good results.

Various modelling problems in the real world are generally influenced by many potential inputs that can be incorporated into the built model. Therefore, an investigation is needed to determine the appropriate potential input that is made a priority. There is no definite procedure for choosing an ANFIS architecture that combines input variables, number of MFs, and ANFIS rules to find the optimal ANFIS. In general, there is a trial and error to find the input variable and the number of MFs. There is no standard method to determine this, therefore, various proposed new methods were given and carried out by several researchers. How to perform preprocessing to obtain optimal ANFIS is a topic discussed by several researchers, namely Azadeh et al. (2011), Polat (2012), and Yunos et al. (2008). How to find the best ANFIS model, i.e. how to find a combination in ANFIS architecture the number of input variables and the number of MFs has also been studied by several researchers such as Jang et al. (1997), Nauck (2000), Prasad et al. (2016), Tarno et al. (2017), and Septiarini and Musikasuwani (2018).

Many time series data relating to the economy are affected by many interventions such as government political policies, disaster events, or holidays in a long period of time. Interventions that can affect the data need to be considered so that data analysis results can be described properly. In real cases, some products and consumer behaviour patterns are related to the occurrence of holiday events that result in changes in the number of sales of a product according to the holiday events that occur. The religious holidays that occur are not always influenced by the Gregorian calendar, which routinely occurs on the same date and time for each period. This

phenomenon is known as the calendar effect. Several studies on the effect of calendars on time series data include Cleveland and Delvin (1982), Hillmer (1982), Kling and Gao (2005), Liu (1980), Mills and Andrew (1995), Seyyed et al. (2005), Sullivan et al. (2001), and Vergin and McGinnis (1999).

One of the holiday events that occurred in Indonesia is Eid al-Fitr. Eid al-Fitr holidays are calculated based on the lunar calendar so that the time of occurrence in each year is constantly changing and has a forward pattern that shifts around 11 to 12 days. In this study, the effect of the Eid Al-Fitr holiday calendar on time series data was observed. For this purpose, actual data on the number of visitors to Tanjung Priok Port, the most populous Port in Indonesia influenced by the Eid al-Fitr holiday, is used.

The motivation in this research arises from the fact that no published works have examined time series data with calendar variations using ANFIS. With the holiday effect on time series observation data, the ARIMA model to determine the input variables proposed by Jang (1996) is no longer able and suitable to describe the data adequately in this study, therefore, the ARIMAX model is proposed to accommodate the calendar effect. By utilizing soft computing and the advantages of the ANFIS method, the hybrid ARIMAX ANFIS method will be applied to time series data with calendar variations. This paper aims to develop an ANFIS optimal architecture formation method proposed by Tarno et al. (2013) to determine the input and number of MFs in ANFIS architecture, especially for time series data influenced by calendar effects. This paper is organized as follows. Next section contains theoretical studies of identification methods in ANFIS of a time series affected by calendar effects and describes the ANFIS architecture. The following section describes the structure and learning rules of adaptive networks in time series with calendar effect. Subsequent section introduces the procedure proposed in this paper. Application examples of case studies are given in the next section. The last section concludes this paper by providing extensions and future directions for this work.

## MATERIALS AND METHODS

### AUTOREGRESSIVE INTEGRATED MOVING AVERAGE WITH EXOGENOUS VARIABLES (ARIMAX)

Time series modeling can be done by using historical data and adding other variables that are considered to have a significant influence on the data to improve forecasting accuracy. ARIMAX model is a modification of the ARIMA

model with the addition of predictor variables. In this model, the factors affecting the response variable  $Z$  at time  $t$  are not only a function of  $Z$  variable in time but also by other independent variables at time  $t$ . In general, the shape of the ARIMAX( $p,d,q$ ) model is given by the equation

$$(1 - B)^d \phi_p(B) Z_t = \mu + \theta_q(B) a_t + \alpha_1 X_{1t} + \dots + \alpha_k X_{kt},$$

with  $Z_t$  response variable,  $\phi_p$  is autoregressive parameter to- $p$ ,  $\theta_q$  is moving average parameter to- $q$ ,  $X_{it}$ ,  $i = 1, 2, \dots$ ,  $k$  are the time series of exogenous variables (predictors),  $\alpha_1, \dots, \alpha_k =$  coefficient of exogenous variables, with  $\phi_p(B) = (1 - \theta_1 B - \dots - \theta_p B^p)$  and  $\theta_q(B) = (1 - \theta_1 B - \dots - \theta_q B^q)$  are AR and MA processes, respectively. In this model,  $Z_t$  and  $X_{it}$  are assumed to be stationary. ARIMAX modelling steps are generally the same as ARIMA modelling through three-stage: model identification, parameter estimation, and diagnostic checking Box et al. (2015). But in model estimation, the components of other independent variables are added to the model.

#### ANFIS ARCHITECTURE

ANFIS Architects consist of five layers built with three main components consecutive fuzzification, fuzzy inference systems, defuzzification. In the time series data with calendar effects, there are additional variables that can be input candidates, namely dummy variables, which indicate the calendar effect on the data. If there are  $p$  lag input variables, say  $Z_{t-1}, Z_{t-2}, \dots, Z_{t-p}$  and a number of  $i$  dummy variables that represent the calendar effect on  $D_1, D_2, \dots, D_i$  data and one output  $Z_t$  with the number of membership functions is  $m$ , assuming the first-order Sugeno rules is as follows.

If  $Z_{t-1}$  is  $A_{11}$ ,  $Z_{t-2}$  is  $A_{21}$ ,  $\dots$ ,  $Z_{t-p}$  is  $A_{p1}$ ,  $D_1$  is  $A_{(p+1)1}$ ,

$D_2$  is  $A_{(p+2)1}$   $\dots$ ,  $D_i$  is  $A_{(p+i)1}$ , then

$$Z_t^{(1)} = \theta_{11} Z_{t-1} + \theta_{12} Z_{t-2} + \dots + \theta_{1p} Z_{t-p} + \theta_{1(p+1)} D_1 + \theta_{1(p+2)} D_2 + \dots + \theta_{1(p+i)} D_i.$$

If  $Z_{t-1}$  is  $A_{12}$ ,  $Z_{t-2}$  is  $A_{22}$ ,  $\dots$ ,  $Z_{t-p}$  is  $A_{p2}$ ,  $D_1$  is  $A_{(p+1)2}$ ,

$D_2$  is  $A_{(p+2)2}$   $\dots$ ,  $D_i$  is  $A_{(p+i)2}$ , then

$$Z_t^{(2)} = \theta_{21} Z_{t-1} + \theta_{22} Z_{t-2} + \dots + \theta_{2p} Z_{t-p} + \theta_{2(p+1)} D_1 + \theta_{2(p+2)} D_2 + \dots + \theta_{2(p+i)} D_i.$$

$\vdots$

If  $Z_{t-1}$  is  $A_{1m}$ ,  $Z_{t-2}$  is  $A_{2m}$ ,  $\dots$ ,  $Z_{t-p}$  is  $A_{pm}$ ,  $D_1$  is  $A_{(p+1)m}$ ,

$D_2$  is  $A_{(p+2)m}$   $\dots$ ,  $D_i$  is  $A_{(p+i)m}$ ,

then  $Z_t^{(m)} = \theta_{m1} Z_{t-1} + \theta_{m2} Z_{t-2} + \dots + \theta_{mp} Z_{t-p} + \theta_{m(p+1)} D_1 + \theta_{m(p+2)} D_2 + \dots + \theta_{m(p+i)} D_i.$

where  $Z_{t-k}$  is  $A_{kj}$  as premise parameter, while

$$Z_t^{(j)} = \theta_{j0} \sum_{k=1}^{p+i} \theta_{jk} Z_{t-k}$$

as a consequent parameter,  $\theta_{jk}$ ,  $\theta_{j0}$  as a linear parameter,  $A_{kj}$  as a nonlinear parameter with  $j = 1, 2, \dots, m$  (rules),  $k = 1, 2, \dots, p, p+1, \dots, p+i$ .

If the firing strength for  $m$  (rules) is  $Z_t^{(1)}, Z_t^{(2)}, \dots, Z_t^{(m)}$ , are  $w_1, w_2, \dots, w_m$ , then the output of  $Z_t$  can be expressed in the form

$$Z_t = \frac{w_1 Z_t^{(1)} + w_2 Z_t^{(2)} + \dots + w_m Z_t^{(m)}}{w_1 + w_2 + \dots + w_m}$$

Here, if the dummy variable calendar effects  $D_1, D_2, \dots, D_i$  are expressed as  $Z_{t-(p+1)}, Z_{t-(p+2)}, \dots, Z_{t-(p+i)}$ , then the first order Sugeno rules become.

If  $Z_{t-1}$  is  $A_{11}$ ,  $Z_{t-2}$  is  $A_{21}$ ,  $\dots$ ,  $Z_{t-p}$  is  $A_{p1}$ ,  $Z_{t-(p+1)}$  is

$A_{(p+1)1}$ ,  $Z_{t-(p+2)}$  is  $A_{(p+2)1}$   $\dots$ ,

$Z_{t-(p+i)}$  is  $A_{(p+i)1}$ , then  $Z_t^{(1)} = \theta_{11} Z_{t-1} + \theta_{12} Z_{t-2} + \dots +$

$\theta_{1p} Z_{t-p} + \theta_{1(p+1)} Z_{t-(p+1)} + \theta_{1(p+2)} Z_{t-(p+2)} + \dots +$

$\theta_{1(p+i)} Z_{t-(p+i)}$ .

$\vdots$

If  $Z_{t-1}$  is  $A_{1m}$ ,  $Z_{t-2}$  is  $A_{2m}$ ,  $\dots$ ,  $Z_{t-p}$  is  $A_{pm}$ ,  $Z_{t-(p+1)}$

is  $A_{(p+1)m}$ ,  $Z_{t-(p+2)}$  is  $A_{(p+2)m}$   $\dots$ ,

$Z_{t-(p+i)}$  is  $A_{(p+i)m}$ , the  $Z_t^{(m)} = \theta_{m1} Z_{t-1} + \theta_{m2} Z_{t-2} +$

$\dots + \theta_{mp} Z_{t-p} + \theta_{m(p+1)} Z_{t-(p+1)} + \theta_{m(p+2)} Z_{t-(p+2)} +$

$\theta_{m(p+i)} Z_{t-(p+i)}$ .

ANFIS architecture illustrated in Figure 1 consists of five layers (Jang et al. 1997) described below.

*Layer 1* Each node in the first layer is adaptive with one activation function. The output of each node is the degree of membership value given by the input of the membership function.

$$\begin{aligned} &\mu_{A_{11}} Z_{t-1}, \mu_{A_{12}} Z_{t-1}, \dots, \mu_{A_{1m}} Z_{t-1}, \mu_{A_{21}} Z_{t-2}, \mu_{A_{22}} Z_{t-2}, \dots, \\ &\mu_{A_{2m}} Z_{t-2}, \dots, \mu_{A_{p1}} Z_{t-p}, \mu_{A_{p2}} Z_{t-p}, \dots, \mu_{A_{pm}} Z_{t-p}, \dots, \\ &\mu_{A_{(p+1)1}} Z_{t-(p+1)}, \mu_{A_{(p+1)2}} Z_{t-(p+1)}, \dots, \mu_{A_{(p+1)m}} Z_{t-(p+1)}, \dots, \\ &\mu_{A_{(p+i)1}} Z_{t-(p+i)}, \mu_{A_{(p+i)2}} Z_{t-(p+i)}, \dots, \mu_{A_{(p+i)m}} Z_{t-(p+i)} \end{aligned}$$

The membership function used in this study is the Gaussian membership function (gaussmf) which can be stated as  $\mu_{A_{kj}}(Z_{t-k}) = \exp\left(-\frac{1}{2}\left(\frac{Z_{t-k} - c_{jk}}{a_{jk}}\right)^2\right)$ , with  $j = 1, 2, \dots, m; k = 1, 2, \dots, p, p + 1, \dots, p + i$ . This parameter is called the premise parameter.

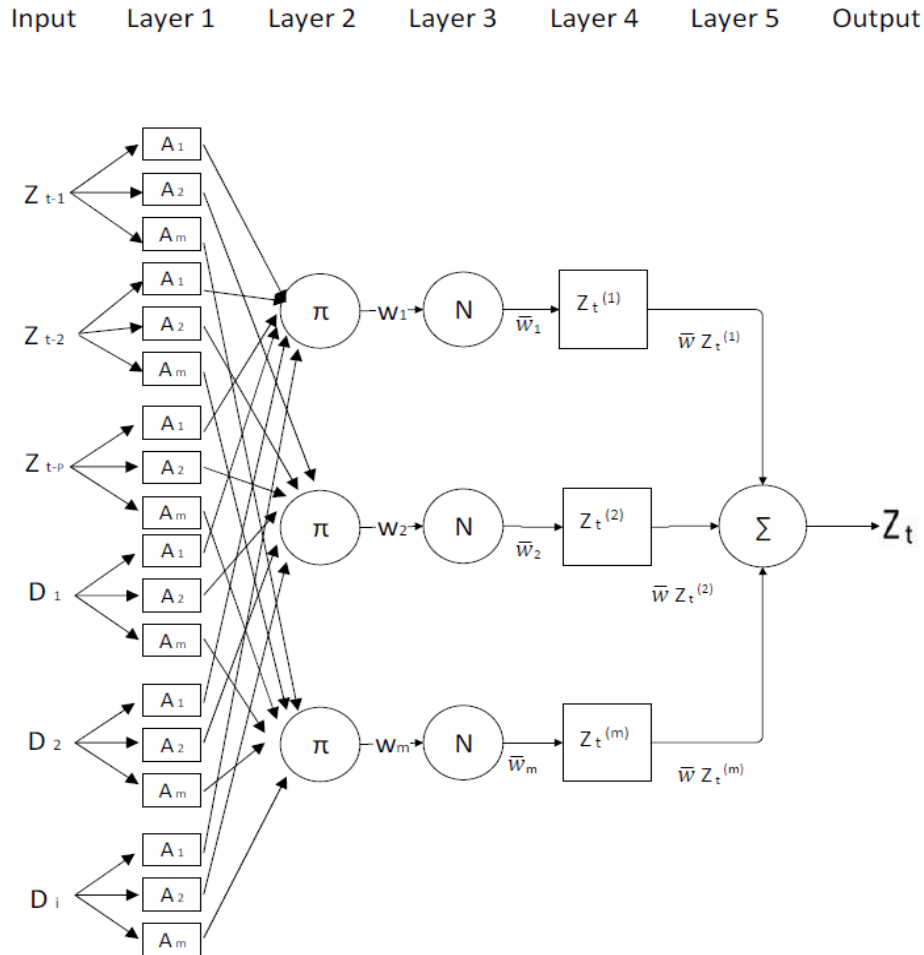

FIGURE 1. ANFIS architecture with a dummy calendar effect

*Layer 2* Each node in the second layer is a fixed node where the output of this layer is the sum of the incoming signals. Generally used AND fuzzy operators. Each node represents the firing strength of  $w_j$  from rule to  $j$ -th.

$$w_j = \prod_{k=1}^{p+i} \mu_{A_{kj}}(Z_{t-k}), \quad j = 1, 2, \dots, m$$

*Layer 3* All nodes in this layer are fixed nodes, which is the result of calculating the ratio of firing strength to  $j$ -th with the sum of all the existing firing strengths of the rules.

$$\bar{w}_j = \frac{w_j}{\sum_{j=1}^m w_j}$$

*Layer 4* Every node is an adaptive node with output for each node defined as

$$\bar{w}_i Z_t^{(j)} = \bar{w}_i(\theta_{j1}Z_{t-1} + \theta_{j2}Z_{t-2} + \dots + \theta_{jp}Z_{t-p} + \theta_{j(p+1)}Z_{t-(p+1)} + \dots + \theta_{j(p+i)}Z_{t-(p+i)})$$

with  $j = 1, 2, \dots, m$  and  $w_j$  is the normalized firing strength in the third layer, with  $\theta_{j1}, \theta_{j2}, \dots, \theta_{jp}, \theta_{j(p+1)}, \dots, \theta_{j(p+i)}$  being the consequent parameters.

*Layer 5* This layer produces a single node that is a fixed node that computes all incoming signals, the output is the overall output of the network.

$$Z_t = \sum_{j=1}^m \bar{w}_i(\theta_{j1}Z_{t-1} + \theta_{j2}Z_{t-2} + \dots + \theta_{jp}Z_{t-p} + \theta_{j(p+1)}Z_{t-(p+1)} + \dots + \theta_{j(p+i)}Z_{t-(p+i)})$$

We used a hybrid learning algorithm, which in forward pass the consequent parameter is identified by the least-squares method. Meanwhile, in the backward pass, the premise parameter is updated using gradient descent.

Based on architecture with these five layers, the general model of ANFIS can be expressed as

$$Z_t = \sum_{j=1}^m \sum_{k=1}^{p+i} \theta_{jk} (\bar{w}_j Z_{t-k}) + \sum_{j=1}^m \theta_{j0} \bar{w}_j$$

#### LAGRANGE MULTIPLIER TEST PROCEDURE FOR ADDING VARIABLE

Lagrange Multiplier (LM) test is used to test hypotheses related to adding variables and the number of membership functions to the ANFIS architecture. The determination of input variables using LM test procedure, begins with testing using a minimum number of inputs, number of membership functions, and rules. The first stage, the ANFIS model was formed by using 1 input variable selected from several input candidates, 2 number of membership functions, and 2 rules. The variable, which was first tested to be included in the ANFIS architecture, was the variable with the largest  $R^2$  value from the previous partial test.

In data with calendar effects, additional variables can be input candidates, namely dummy variables that refer to the calendar effect on the data. For  $p$  lag input variables, say  $Z_{t-1}, Z_{t-2}, \dots, Z_{t-p}$  and a number of  $i$  dummy variables that state the calendar effect symbolized by  $D_1, D_2, \dots, D_i$  with the number of MFs of  $m$ , then the restricted model for this case can be stated as

$$Z_t = \sum_{j=1}^m \sum_{k=1}^{p+i} \theta_{jk} (\bar{w}_j Z_{t-k}) + \sum_{j=1}^m \theta_{j0} \bar{w}_j + \varepsilon_t$$

where  $\varepsilon_t \sim N(0, \sigma_\varepsilon^2)$  and unrestricted model to add one input  $Z_{t-(p+i+1)}$  is

$$Z_t = \sum_{j=1}^m \sum_{k=1}^{p+i+1} \theta_{jk} (\bar{w}_j Z_{t-k}) + \sum_{j=1}^m \theta_{j0} \bar{w}_j + v_t$$

where  $v_t \sim N(0, \sigma_v^2)$ .

The null hypothesis for testing the addition of variables is formulated as follows,

$$H_0: \theta_{1(p+i+1)} = \theta_{2(p+i+1)} = \dots = \theta_{m(p+i+1)} = 0$$

If the  $LM = nR_{\varepsilon_t}^2 > \chi_{(\alpha, df)}^2$  then  $H_0$  is rejected.

The LM test introduced by Lee et al. (1993) and Terasvirta et al. (1994) was also used to test linearity. The test is carried out through the  $\chi^2$  test with the following procedure (Gujarati 2009).

- i. Regress  $Z_t$  to  $Z_{t-1}, Z_{t-2}, \dots, Z_{t-p}, Z_{t-(p+1)}, \dots, Z_{t-(p+i)}$  and estimate the parameters on the restricted model using the OLS method.
- ii. Calculate the residual estimated  $\hat{\varepsilon}_t$  from the regression, with

$$\hat{\varepsilon}_t = Z_t - \sum_{j=1}^m \sum_{k=1}^{p+i} \theta_{jk} (\bar{w}_j Z_{t-k}) - \sum_{j=1}^m \theta_{j0} \bar{w}_j$$

Regress  $\hat{\varepsilon}_t$  to  $Z_{t-1}, Z_{t-2}, \dots, Z_{t-p}, Z_{t-(p+1)}, \dots, Z_{t-(p+i)}$  and  $m$  additional predictors, then calculate the coefficient of determination  $R^2$  from the regression.

#### THE PROCEDURE OF THE PROPOSED METHOD: ARIMAX-ANFIS BASED THE LM TEST

The determination of ANFIS input in time series cases can be identified by the significant lag partial autocorrelation function (PACF) plot. ARIMA subset model can be formed based on significant lag, which is then used to model time series data affected by the Eid al-Fitr holidays. The subset ARIMA model can be easily identified, estimated, and used for forecasting by forming a representative parsimony model. Furthermore, the subset ARIMA develops into the ARIMAX by adding a calendar effect variable as an exogenous variable.

At this stage, the variable that refers to the Eid al-Fitr holiday calendar effect intervention is defined. Forming a calendar effect variable is done in the following two ways.

a. Dummy variable calendar effect

The first way is to use a dummy variable to declare the Eid al-Fitr holiday.

$$D_{t-1} = \begin{cases} 1 & \text{month before Eid al-Fitr} \\ 0 & \text{other month} \end{cases}$$

$$D_t = \begin{cases} 1 & \text{month of Eid al-Fitr} \\ 0 & \text{other month} \end{cases}$$

$$D_{t+1} = \begin{cases} 1 & \text{month after Eid al-Fitr} \\ 0 & \text{other month} \end{cases}$$

In this model, the intercept is removed to avoid the dummy variable trap.

b. Variable days proportion calendar effects

The second method is done by calculating day proportions by assuming Eid al-Fitr events are distributed uniformly over 10 days, starting from 3 days before Eid and 7 days after that, including Eid al-Fitr (Liu 1986). The days proportion calendar effect  $DP_t$  are set as follows and shown in Table 1.

TABLE 1. The days proportion of the Eid al-Fitr calendar effect

| Year | Date | Month | Week | $DP_t$ | $DP_t$ | $DP_{t+1}$ |
|------|------|-------|------|--------|--------|------------|
| 2006 | 24   | 10    | 4    | 0      | 1      | 0          |
| 2007 | 13   | 10    | 2    | 0      | 1      | 0          |
| 2008 | 1    | 10    | 1    | 0.3    | 0.7    | 0          |
| 2009 | 20   | 9     | 3    | 0      | 1      | 0          |
| 2010 | 9    | 9     | 2    | 0      | 1      | 0          |
| 2011 | 30   | 8     | 4    | 0      | 0.5    | 0.5        |
| 2012 | 18   | 8     | 3    | 0      | 1      | 0          |
| 2013 | 7    | 8     | 3    | 0      | 1      | 0          |
| 2014 | 28   | 7     | 4    | 0      | 0.7    | 0.3        |
| 2015 | 17   | 7     | 3    | 0      | 1      | 0          |
| 2016 | 6    | 7     | 1    | 0      | 1      | 0          |
| 2017 | 25   | 6     | 4    | 0      | 0.9    | 0.1        |
| 2018 | 15   | 6     | 3    | 0      | 1      | 0          |
| 2019 | 5    | 6     | 1    | 0      | 1      | 0          |

THE PROPOSED PROCEDURE

Modeling problems in the real world are generally influenced by many potential inputs that can be incorporated into the built model. Therefore, an investigation is needed to determine the appropriate potential input that is made a priority. This study constructs the ANFIS architecture with preprocessing stages using ARIMAX and the LM test inference procedure. The LM test is used to test hypotheses for the determination of input variables and the number

of membership functions to form the optimal ANFIS architecture for prediction of time series, which is affected by calendar effects. The data analysis steps in this study are as follows.

PREPROCESSING DATA

Input determination begins by plotting a PACF plot from time series data. The PACF plot is used to identify whether a lag variable affects the data. If the PACF lag value to  $k(\phi_{kk})$  twice the standard error  $\phi_{kk}$ , then the



lag- $k$  can be identified as an ANFIS input variable. Based on the significant lag and calendar effect, the ARIMAX model can be identified. This model contains several input variables that can be entered into the ANFIS model. Furthermore, the formation of the ARIMAX model is continued with parameter estimation to see significant variables, and diagnostic testing is carried out by testing the residual independence and normality. The ARIMAX model that meets all the conditions with the smallest Akaike Information Criterion (AIC) value is then determined as a model of the ARIMAX calendar effect.

#### FORECASTING WITH ANFIS

##### *Determine the appropriate input variables*

The first input to be entered in the model is determined based on the  $R^2$  value. The variable with the largest  $R^2$  will be the first input. Determination of variable inputs in the ANFIS model is done one by one on all existing input candidates until all suitable input candidates are tested. At this stage, all input variables that will meet the LM test will be obtained. The optimization of variable input stops when the LM test value is not significant for the addition of input. At this stage, taking into account the principle of parsimony, ANFIS architecture is used with two membership functions and two rules.

The steps for using the LM Test to determine the input variable in accordance with the subsection *LM Test Procedure for Adding Variable* are described as follows.

i. Choose the first input variable that has the largest  $R^2$ .

ii. Estimating parameters in the restricted ANFIS model with the output variable  $Z_t$ .

Suppose the first input variable is  $Z_{t-1}$ , then  $Z_t = \overline{w}_1(\hat{\theta}_{11}Z_{t-1} + \hat{\theta}_{10}) + \overline{w}_2(\hat{\theta}_{21}Z_{t-1} + \hat{\theta}_{20}) + \varepsilon_t$ .

iii. Calculates the estimated residual ( $\varepsilon_t$ ) value of the restricted model.

iv. Enter an additional candidate variable input that is the candidate input variable with the next largest  $R^2$  value, supposed  $Z_{t-2}$ .

v. Form an unrestricted ANFIS model to increase the number of input lag variables (input becomes 2) with the residuals of the restricted model being input variables

$$\varepsilon_t = \overline{w}_1(\hat{\theta}_{11}Z_{t-1} + \hat{\theta}_{12}Z_{t-1} + \hat{\theta}_{10}) + \overline{w}_2(\hat{\theta}_{21}Z_{t-2} + \hat{\theta}_{22}Z_{t-2} + \hat{\theta}_{20}) + v_t.$$

vi. Calculates the value of  $R_{\varepsilon_t}^2$  from the regression estimation of residual  $\varepsilon_t$  values and unrestricted ANFIS models for the addition of one input lag.

vii. Determine the conclusions of the hypothesis LM test.

Repeat steps (i) to (vii) until all the candidate input variables obtained from the best ARIMAX model are all tested. Furthermore, increasing the number of input variables continues so that all the inputs variables can be determined.

*Determine the optimal number of membership functions.*

The steps for using the Lagrange Multiplier Test to determine the number of membership functions is as follows.

i. Forming the ANFIS model by entering all the input variables selected in the previous stage by increasing the number of clusters starting from 2 clusters then calculating the RMSE and MAPE value of the ANFIS architecture that was formed.

ii. Increase the number of membership functions to the optimal number of membership functions that provide the smallest RMSE and MAPE value.

iii. Determine the optimal number of membership functions that provide the smallest RMSE and MAPE using the LM test previously described.

##### *Forecasting*

Forecasting is done using the ANFIS architecture from the results in *Determine the optimal number of membership functions* and *Forecasting* steps.

i. The initial stage is done by determining the input and output variables.

ii. Divide the data into two parts, namely training (insample) and testing (outsample).

iii. Determine the Gauss function as membership function.

iv. Use the number of MFs that satisfy the LM test obtained in *Forecasting* steps.

v. Training ANFIS parameters with the training

and testing data. At this stage, the RMSE and MAPE values for the training and testing process for all ANFIS architectures will be obtained. The best ANFIS

architecture is determined by looking at the smallest RMSE and MAPE in the testing data.

The procedure of the method proposed in this study is

**Flowchart of ARIMAX ANFIS Procedure Based on LM-Tes**

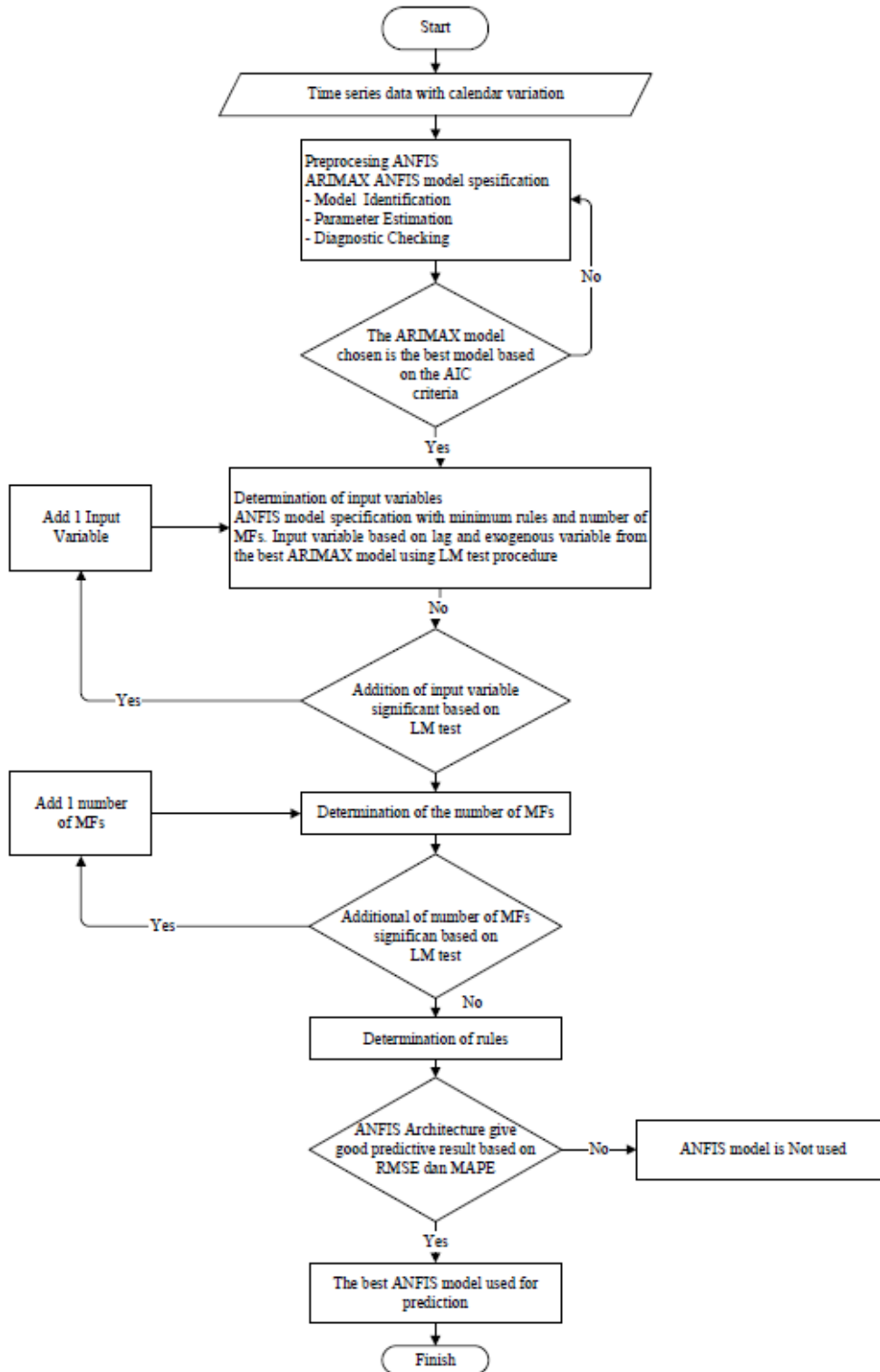

FIGURE 2. The procedure for the proposed method



illustrated in Figure 2.

ACCURACY CRITERIA

There are many criteria that can be used to evaluate forecasting methods, the accuracy of forecasting is generally the basis for determining the appropriate model. Measurement error forecasting accuracy has been widely studied by experts to investigate the accuracy of various forecasting methods (Makridakis et al. 1997). There are three performance measurements used in this study to evaluate the accuracy of the proposed methods both in training and testing data, namely Root Mean Square Error (RMSE), Mean Absolute Percentage Error (MAPE) and Coefficient of determination ( $R^2$ ). These three measurement criteria are stated with,

$$RMSE = \sqrt{\frac{1}{n} \sum_{t=1}^n (Z_t - \hat{Z}_t)^2}$$

$$MAPE = 100 \times \frac{1}{n} \sum_{t=1}^n \left| \frac{Z_t - \hat{Z}_t}{Z_t} \right|$$

$$R^2 = 1 - \frac{\sum_t (Z_t - \hat{Z}_t)^2}{\sum_t (Z_t - \bar{Z}_t)^2}$$

RESULTS AND DISCUSSION

This paper's data study is the monthly volume of visitors to Jakarta's Tanjung Priok Port from January 2006 to November 2019 obtained from Statistics Indonesia. By examining the data, the Eid holiday causes an increase in the recurring pattern in the months of Eid al-Fitr each year. Figure 3(a) illustrates this pattern. Based on the

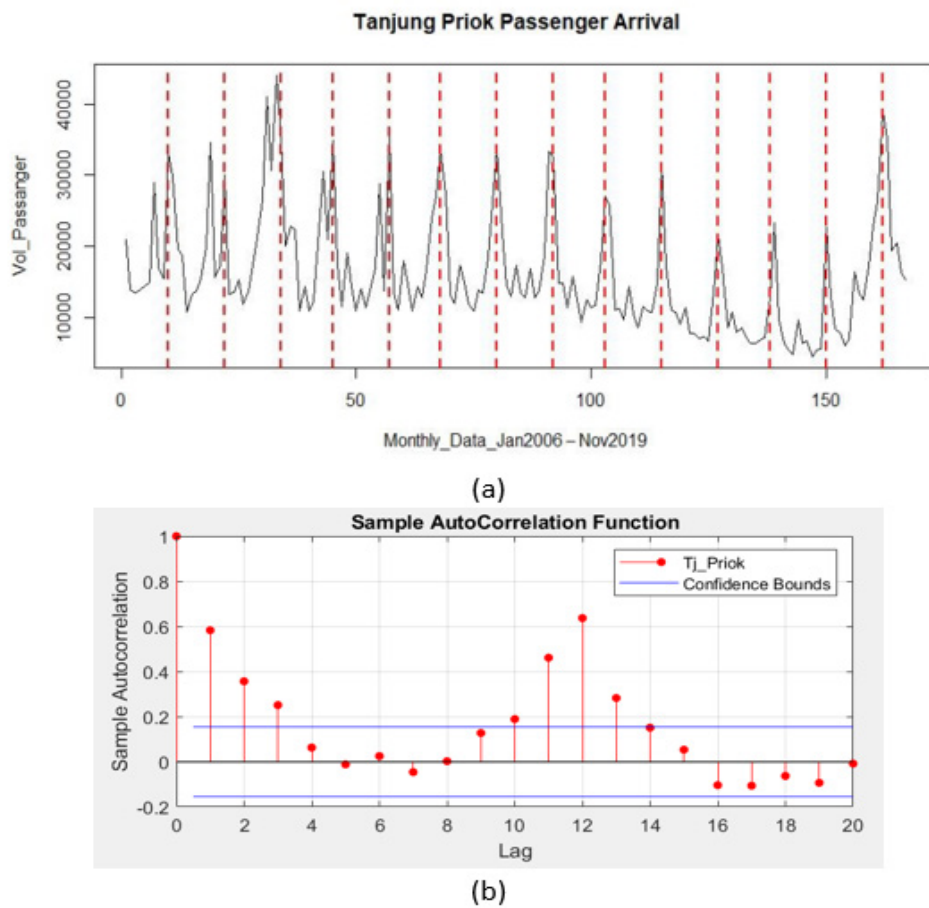

FIGURE 3. (a) Tanjung Priok Port Passenger Plot, (b) Sample PACF Plot

data plot, the data has a recurring pattern every 11 or 12 months. There is a pattern that is almost the same in every data point with a red line. During this time, there was a pattern of a significant increase in data. This pattern indicates a calendar effect on the data.

After determining the calendar effect dummy variable (Table 1), then at the data preprocessing stage the input variable was determined by applying the ARIMAX and LM test models. This process begins with modeling the data using ARIMA to see the significant lag and the most efficient model. In this study, for convenience and

simplicity, the ARIMA model used is limited to only using lag data from the AR section and does not take into account the lag in the MA section. This is done by only paying attention to the PACF plot of the observed data. Based on the PACF plot in Figure 3(b), it can be seen that the significant lag is lag 1, 2, 3, 11,12, 13. From Table 2, based on the AIC model value, significant lag, and the number of variables that affect the model, based on the parsimony principle, the ARIMA([1,11,12],1,0) model chosen as the best model used for the next stage.

TABLE 2. Determining significant input variable using

ARIMA

| Model           | ARIMA<br>([1,11,12],1,0) | ARIMA<br>([11,12],1,0) | ARIMA<br>([11,12,13],1,0) | ARIMA<br>([1,2,3,11,12,13],1,0) | ARIMA<br>([1,11,12,13],1,0) | ARIMA<br>([1,2,11,12,13],1,0) |
|-----------------|--------------------------|------------------------|---------------------------|---------------------------------|-----------------------------|-------------------------------|
| $a_1$           | <i>Sig</i>               |                        |                           | <i>Sig</i>                      | <i>Sig</i>                  | <i>Sig</i>                    |
| $a_2$           |                          |                        |                           |                                 |                             | <i>Sig</i>                    |
| $a_3$           |                          |                        |                           | <i>Not Sig</i>                  |                             |                               |
| $a_{11}$        | <i>Sig</i>               | <i>Sig</i>             | <i>Sig</i>                | <i>Sig</i>                      | <i>Sig</i>                  | <i>Sig</i>                    |
| $a_{12}$        | <i>Sig</i>               | <i>Sig</i>             | <i>Sig</i>                | <i>Sig</i>                      | <i>Sig</i>                  | <i>Sig</i>                    |
| $a_{13}$        |                          |                        | <i>Sig</i>                | <i>Sig</i>                      | <i>Sig</i>                  | <i>Sig</i>                    |
| $R^2$           | 0.63                     | 0.56                   | 0.57                      | 0.67                            | 0.67                        | 0.67                          |
| SSR             | 3.35E+09                 | 4.16E+09               | 4.05 E+09                 | 3.05E+09                        | 3.14E+09                    | 3.08 E+09                     |
| AIC             | 19.763                   | 19.984                 | 19.964                    | 19.729                          | 19.738                      | 19.725                        |
| White Noise     |                          |                        |                           |                                 |                             |                               |
| Num of Variable | 3                        | 2                      | 3                         | 6                               | 4                           | 5                             |

Furthermore, calendar effect variables that significantly affect the data will also be candidates for input variables in ANFIS. Table 3 shows the calendar effect ARIMAX model which contains significant variables as an alternative to determining the input variables for the ANFIS model. There are six candidate input variables that can be included in the ANFIS model. The  $R^2$  for each variable are 0.396 for *Lag-1*, 0.255 for *Lag-11*, 0.478 for *Lag-12*, 0.259 for  $D_t$ , 0.020 for  $D_{t+1}$  and 0.259 for  $DP_t$ . The following Table 4 is the result of testing the addition of variable input in the Tanjung Priok Port Passenger data. Based on the value of  $R^2$ , *Lag-12* is selected as the first input variable of the ANFIS architecture. The next step is to add other inputs to the

ANFIS architecture in stages according to the large order value of  $R^2$ . The step-by-step results from the analysis of adding input variables are shown in Table 4. The LM test value of the three models shows a value greater than the  $\chi^2_{(\alpha, df)}$  which means that additional input variables can be accepted and included in the model. We can conclude that the optimal input variables for the calendar effect of dummy models are *Lag-1*, *Lag-11*, *Lag-12*,  $D_t$ , and  $D_{t+1}$ . Meanwhile, the optimal input variables for the days proportion calendar effect models are *Lag-1*, *Lag-11*, *Lag-12*, and  $DP_t$ . This shows that, all significant input candidates based on the ARIMAX model can be entered into ANFIS input variables.

TABLE 3. Forecasting calendar effect using ARIMAX

| Model   | Input Variable     | $R^2$ | SSR      | AIC    | White Noise | Normality Residual |
|---|--------------------|-------|----------|--------|-------------|--------------------|
| ARIMA([1,11,12],1,0)                          | <i>Lag-1</i>       | 0.63  | 3.45E+09 | 19.806 | √           | ×                  |
|   | <i>Lag-11</i>      |       |          |        |             |                    |
|   | <i>Lag-12</i>      |       |          |        |             |                    |
| ARIMA([1,11,12],1,0)<br>with $D_t, D_{t+1}$ , | <i>Lag-1</i>       | 0.64  | 3.35E+09 | 19.789 | √           | √                  |
|   | <i>Lag-11</i>      |       |          |        |             |                    |
|   | <i>Lag-12</i>      |       |          |        |             |                    |
|   | $D_t$<br>$D_{t+1}$ |       |          |        |             |                    |
| ARIMA([1,11,12],1,0)<br>with $DP_t$           | <i>Lag-1</i>       | 0.66  | 3.25E+09 | 19.763 | √           | √                  |
|   | <i>Lag-11</i>      |       |          |        |             |                    |
|   | <i>Lag-12</i>      |       |          |        |             |                    |
|   | $DP_t$             |       |          |        |             |                    |

TABLE 4. ANFIS variable input determination

| Model   | Input Variable                             | RMSE   | LM Stat | Conclusion |
|---|--|--------|---------|------------|
| Without dummy variables calendar effect       |  |        |         |            |
| ARIMA([1,11,12],1,0)                          | <i>Lag-12</i>                              | 5982.4 | 68.288  | var added  |
|   | <i>Lag-12, Lag-1</i>                       | 5509.5 | 31.072  | var added  |
|   | <i>Lag-12, Lag-1, Lag-11</i>               | 5374.9 | 36.421  | var added  |
| Dummy variables calendar effect               |  |        |         |            |
| ARIMA([1,11,12],1,0)<br>with $D_t, D_{t+1}$ , | <i>Lag-12</i>                              | 5982.4 | 68.295  | var added  |
|   | <i>Lag-12, Lag-1</i>                       | 5509.5 | 31.106  | var added  |
|   | <i>Lag-12, Lag-1, D_t</i>                  | 5115.0 | 46.542  | var added  |
|   | <i>Lag-12, Lag-1, D_t, Lag-11</i>          | 5012.0 | 50.444  | var added  |
|   | <i>Lag-12, Lag-1, D_t, Lag-11, D_{t+1}</i> | 4559.6 | 66.411  | var added  |
| Days proportion calendar effect variable      |  |        |         |            |
| ARIMA([1,11,12],1,0)<br>with $DP_t$           | <i>Lag-12</i>                              | 5982.4 | 68.302  | var added  |
|   | <i>Lag-12, Lag-1</i>                       | 5509.6 | 31.076  | var added  |
|   | <i>Lag-12, Lag-1, DP_t</i>                 | 5084.0 | 46.712  | var added  |
|   | <i>Lag-12, Lag-1, DP_t, Lag-11</i>         | 5022.9 | 50.000  | var added  |

After obtaining the input variable, the next step is to determine the number of MFs. The number of MFs used starts from 2 and then gradually increases until the maximum number of MFs gives the smallest error value. In determining the optimum number of MFs, a fuzzy C-Means (FCM) clustering technique is used, which is determined by using the LM test with the procedure described earlier.

The number of MFs is restricted so that the estimated number of parameters is not more than the amount of data analyzed so that the resulting error tends to increase. Because the number of parameters estimated does not more than the observational data, 3 are the maximum number of MFs that can be used for models with calendar effects and 4 number of MFs for models without including calendar effects. When using too many MFs, the results obtained may be better, but there is a danger that if too many membership functions are used, the system will become overfitted. Overfitting can make the prediction results too precise for the training data, and therefore that does not give good results on other data (testing).

Table 5 shows that the ANFIS models can use 2 to 4 numbers of MFs because of the LM test value more significant than the  $\chi^2_{(a, df)}$ . For models with calendar effect variables, using 3 number of MFs give the smallest RMSE. At this stage, a significant input variable has been obtained and the optimal number of MFs for the ANFIS architecture will be used for forecasting. Forecasting is carried out using the ANFIS architecture obtained in the previous stage. First, divide the data into two parts: data training (in sample) from January 2006 to December 2016 and data testing (out sample) from January 2017 to November 2019. The input nodes are the previous lagged observation that is significant to the data based on the results of preprocessing data with ARIMAX. At the same time, the output provides the forecasting for future values. The previous lagged that uses as an input variable is a significant lag. The ANFIS architecture model used is a model with a significant input variable and the optimal number of MF based on the LM test. As a limitation, the membership function used in ANFIS is Gaussian. Gaussian chose because of its simple function, with only two parameters (mean and variance) estimated.

TABLE 5. Determination of the number of ANFIS membership function

| Num of MFs  | RMSE   | LM Stat | Conclusion       |
|---|--------|---------|------------------|
| Without dummy variables calendar effect with 3 input variables  |        |         |                  |
| 2   | 6228.4 | 68.316  | MFs can be added |
| 3   | 5097.9 | 11.227  | MFs can be added |
| 4   | 4977.8 | 17.817  | MFs can be added |
| Dummy variables calendar effect with 5 input variables          |        |         |                  |
| 2   | 4549.2 | 103.129 | MFs can be added |
| 3   | 4412.8 | 9.370   | MFs can be added |
| Days proportion calendar effect variable with 4 input variables |        |         |                  |
| 2   | 5013.4 | 94.657  | MFs can be added |
| 3   | 4705.6 | 20.840  | MFs can be added |

Table 6 summarizes the results of ANFIS forecasting in the training and testing stages by using an optimal variable input and numbers of MFs from the previous

step. In a fuzzy system, each number of MFs is considered a rule. Therefore, the number of fuzzy rules is equal to the number of membership functions developed with FCM.

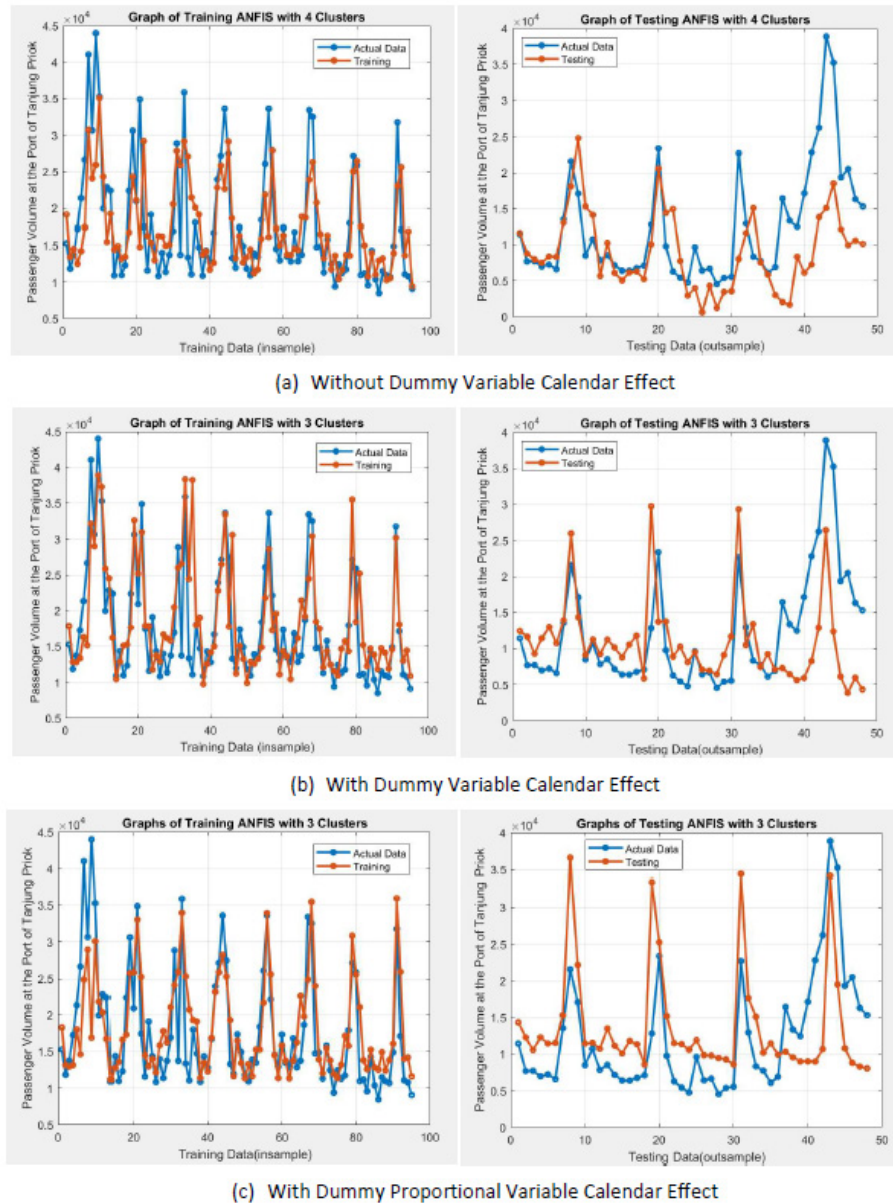

FIGURE 4. Plot training and testing ANFIS

TABLE 6. Training and testing ANFIS

| Number of MFs   | RMSE     |         | MAPE     |         | $R^2$    |         |
|---|----------|---------|----------|---------|----------|---------|
|   | Training | Testing | Training | Testing | Training | Testing |
| Without dummy variables calendar effect with 3 input variables  |          |         |          |         |          |         |
| 4   | 6147.9   | 9119.9  | 9.362    | 14.156  | 0.453    | 0.698   |
| Dummy variables calendar effect with 5 input variables          |          |         |          |         |          |         |
| 3   | 4948.3   | 7799.0  | 7.297    | 13.021  | 0.661    | 0.882   |
| Days proportion calendar effect variable with 4 input variables |          |         |          |         |          |         |
| 3   | 5633.6   | 8437.7  | 8.469    | 13.829  | 0.635    | 0.768   |

In this case, the ANFIS architecture is tested with the best number of MF used based on the previous stage. In the calendar effect dummy model used, the use of several numbers of MFs affects the forecast error value. This shows that increasing the number of MFs to a certain amount can improve accuracy. However, if the number of MFs is used too much, it will make the analysis process longer because more parameters must be estimated. Based on results in Table 6, the optimal architecture for both the dummy and the days proportion calendar effect model is obtained when using three numbers of MFs with five and four input variables, respectively. The RMSE testing value for both models was 7799.0 and 8437.7, respectively, with MAPE testing being 13.021 and 13.829. The testing error use as an accurate measure of the performance model. Therefore, the best model occurs when the testing error is minimal.

In constructing time series models, it is generally assumed that interventions have effect on the overall data pattern. In this study, data on the volume of passengers at Tanjung Priok Port is influenced by calendar variations, namely the effect of the Eid al-Fitr holiday. The shape of the calendar effect patterns that occur on the data during the Eid al-Fitr holiday is seen to have a linear increase. The ARIMAX model represents the calendar effect in the data. By combining the ARIMA model and calendar effect, parameter estimation is obtained. As a comparison, ARIMA model is also formed without a calendar effect. It seems that a model that considers calendar effects provides less error than a model without including calendar effects in the analysis. We can see this from the RMSE and MAPE values of the ARIMA model, which are higher than the ARIMAX model and the smaller coefficient of determination compared to models that include calendar effects. Figure 4 shows an illustration of forecast training and test data with ANFIS optimal architecture. In this study, it has been shown that calendar interventions can significantly influence the data patterns. When there is a calendar effect, an initial approach to the data is needed before identifying the model. This paper presents a comprehensive step for identifying and estimating time series models affected by calendar interventions.

#### CONCLUSION

The proposed method for selecting input and determining the number of MF for ANFIS uses the ARIMAX model, and the LM test is tested on real-world problems; the number of visitors to Tanjung Priok Port

that influenced by the calendar effects. ARIMAX can capture the effect of calendar variations on time series data. Based on the result, LM tests can be considered as an alternative way to determine input variables and number of MFs in ANFIS. Variables that are known to have no significant effect from the beginning have been eliminated so that the possibility of using too many input variables but no significant impact can be minimized. In the time series, data indicated to be influenced by calendar effects, ANFIS training and testing results indicate that for predicting time series data by entering the calendar effect gives better results when compared to without entering the calendar effect variable in the calculation. The small RMSE and MAPE values indicate this. The use of two types of calendar effect variables in this study shows that using the dummy calendar effect provides more accurate results than the days proportion calendar effect. The proposed method can be an alternative way that provides effective results for determining input priorities for ANFIS modelling.

#### ACKNOWLEDGEMENTS

This research was supported by Indonesia Endowment Fund for Education (LPDP) under the Doctoral Fellowship BUDI-DN. The authors thank the reviewers and editor for their valuable comments and suggestions that significantly improved the initial manuscript.

#### REFERENCES

- Azadeh, A., Saberi, M. & Asadzadeh, S.M. 2011. An adaptive network based fuzzy inference system-auto regression - Analysis of variance algorithm for improvement of oil consumption estimation and policy making: The Cases of Canada, United Kingdom, and South Korea. *Applied Mathematical Modelling* 35(2): 581-593.
- Box, G.E., Jenkins, G.M., Reinsel, G.C. & Ljung, G.M. 2015. *Time Series Analysis: Forecasting and Control*. New York: John Wiley & Sons.
- Cleveland, W.S. & Devlin, S.J. 1982. Calendar effects in monthly time series: Modeling and adjustment. *Journal of the American Statistical Association* 77(379): 520-528.
- Duan, X., Zhang, F., Liao, M., Zou, J. & Lv, Y. 2019. Forecasting failure risk of transmission line in ultra-high-voltage networks using ANFIS. *Journal of Intelligent & Fuzzy Systems* 37(4): 4827-4836.
- Gujarati, D.N. 2009. *Basic Econometrics*. 4th ed. New York: Tata McGraw-Hill Education.
- Gunasekaran, M. & Ramaswami, K.S. 2014. A hybrid intelligent system of ANFIS and CAPM for stock portfolio optimization. *Journal of Intelligent & Fuzzy Systems* 26(1): 277-286.



- Hillmer, S.C. 1982. Forecasting time series with trading day variation. *Journal of Forecasting* 1(4): 385-395.
- Jang, J.S.R. 1996. Input Selection for ANFIS Learning. *Proceedings of IEEE 5th International Fuzzy Systems 2*: 1493-1499.
- Jang, J.S. 1993. ANFIS: Adaptive-network-based fuzzy inference system. *IEEE Transactions on Systems, Man, and Cybernetics* 23(3): 665-685.
- Jang, J.S.R., Sun, C.T. & Mizutani, E. 1997. *Neuro-fuzzy and Soft Computing: A Computational Approach to Learning and Machine Intelligence*. New Jersey: Prentice Hall.
- Kamisan, N.A.B., Lee, M.H., Suhartono, S., Hussin, A.G. & Zubairi, Y.Z. 2018. Load forecasting using combination model of multiple linear regression with neural network for Malaysian City. *Sains Malaysiana* 47(2): 419-426.
- Kling, G. & Gao, L. 2005. Calendar effects in Chinese Stock Market. *Annals of Economics and Finance* 6(1): 75-88.
- Lee, T.H., White, H. & Granger, C.W.J. 1993. Testing for neglected nonlinearity in time series models: A comparison of neural networks methods and alternative test. *Journal of Econometrics* 56: 269-290.
- Lei, K.S. & Wan, F. 2012. Applying ensemble learning techniques to ANFIS for air pollution index prediction in Macau. *Proceedings of the 9th International Conference on Advances in Neural Networks, Part 1*. pp. 509-516.
- Liu, L.M. 1986. Identification of time series models in the presence of calendar variation. *International Journal of Forecasting* 2: 357-371.
- Liu, L.M. 1980. Note - Analysis of time series with calendar effects. *Management Science* 26(1): 106-112.
- Liu, X. & Zhou, Z. 2017. A novel prediction model based on particle swarm optimization and adaptive neuro-fuzzy inference system. *Journal of Intelligent & Fuzzy Systems* 33(5): 3137-3143.
- Makridakis, S., Wheelwright, S.C. & Hyndman, R.J. 1997. *Forecasting: Methods and Applications*. 3rd ed. New York: Wiley.
- Mills, T.C. & Andrew Coutts, J. 1995. Calendar effects in The London Stock Exchange FT-SE Indices. *The European Journal of Finance* 1: 79-93.
- Nauck, D. 2000. Data analysis with neuro-fuzzy method. der Fakultat of Informur der Otto-von-Guericke Universit at Magdeburg (Unpublished).
- Nayak, P.C., Sudheer, K.P., Rangan, D.M. & Ramasastri, K.S. 2004. A neuro-fuzzy computing technique for modeling hydrological time series. *Journal of Hydrology* 291(1-2): 52-66.
- Polat, K. 2012. A novel data preprocessing method to estimate the air pollution (SO<sub>2</sub>): Neighbor-Based Feature Scaling (NBFS). *Neural Computing and Applications* 21: 1987-1994.
- Prasad, K., Gorai, A.K. & Goyal, P. 2016. Development of ANFIS Model for air quality forecasting and input optimization for reducing the computational cost and time. *Atmospheric Environment* 128: 246-262.
- Septiarini, T.W. & Musikasuwan, S. 2018. Investigating the performance of ANFIS Model to predict the hourly temperature in Pattani, Thailand. *Journal of Physics: Conference Series* 1097: 012085.
- Seyyed, F.J., Abraham, A. & Al-Hajji, M. 2005. Seasonality in stock returns and volatility: The Ramadan effect. *Research in International Business and Finance* 19(3): 374-383.
- Sood, S.K., Kaur, S. & Chahal, K.K. 2020. An intelligent framework for monitoring dengue fever risk using LDA-ANFIS. *Journal of Ambient Intelligence and Smart Environments* Preprint: 1-16.
- Suhartono, D.E.A., Prastyo, D.D., Kuswanto, H. & Lee, M.H. 2019. Deep neural network for forecasting inflow and outflow in Indonesia. *Sains Malaysiana* 48(8): 1787-1798.
- Sullivan, R., Timmermann, A. & White, H. 2001. Dangers of data mining: The case of calendar effects in stock returns. *Journal of Econometrics* 105(1): 249-286.
- Sumithira, T.R. & Nirmal, A.K. 2014. Performance evaluation of standalone solar photovoltaic system using ANFIS predicted solar radiation: An experimental case study. *Journal of Intelligent & Fuzzy Systems* 26(1): 203-210.
- Tarno, Wilandari, Y., Suparti & Ispriyanti, D. 2017. Volatility modeling of financial time series data using ANFIS. *Advance Science Letters* 23(7): 6562-6566.
- Tarno, Subanar & D. Rosadi. 2013. Analysis of financial time series data using Adaptive Neuro Fuzzy Inference System (ANFIS). *International Journal of Computer Sciences Issues* 10(2): 491-496.
- Terasvirta, T., Tjostheim, D. & Granger, C.W.J. 1994. Aspect modelling nonlinear time series. In *Handbook of Econometrics*, edited by Engle, R.F. & Mc Fadden, D.L. Amsterdam, Netherlands: Elsevier Science B.V.4 Chapter 48: 2919-2957.
- Vergin, R.C. & McGinnis, J. 1999. Revisiting the holiday effect: Is it on holiday? *Applied Financial Economics* 9(5): 477-482.
- Wei, L., Chen, T. & Ho, T. 2011. A hybrid model based on adaptive-network-based fuzzy inference system to forecast Taiwan Stock Market. *Expert System with Applications* 38(11): 13625-13631.
- Yunos, Z.M., Shamsuddin, S.M. & Sallehuddin, R. 2008. Data modeling for Kuala Lumpur Composite Index with ANFIS. *Second Asia International Conference on Modelling and Simulation*. pp. 609-614.

\*Corresponding author; email: putriaji.mat@mail.unnes.ac.id