

# SESSION OF 2025-2026

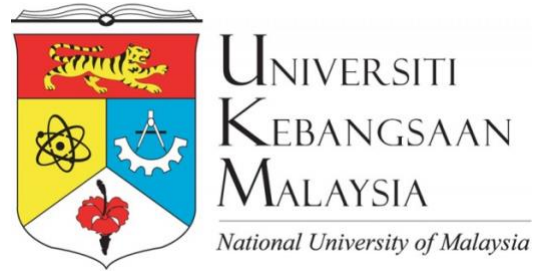

## DOCTOR OF RADIOLOGY (DrRAD) UKM

POST-GRADUATE CLINICAL  
MASTER PROGRAMME

UNIVERSITI KEBANGSAAN MALAYSIA

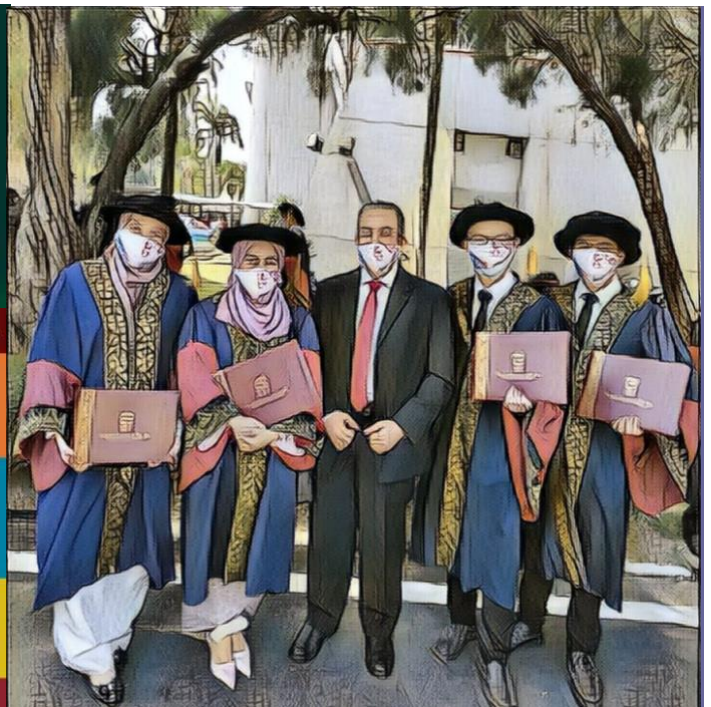
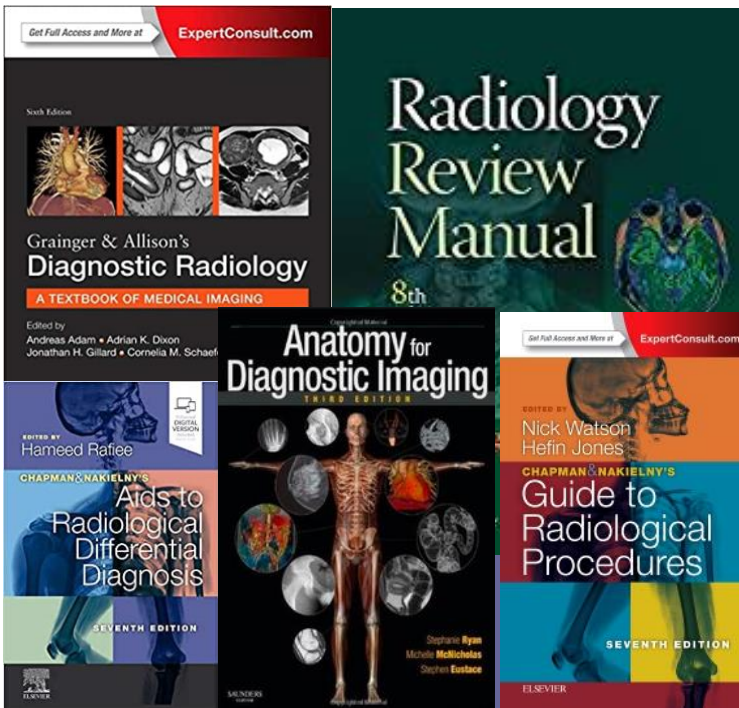

Copyright Universiti Kebangsaan Malaysia 2025

Published by  
JABATAN RADIOLOGI  
Fakulti Perubatan  
Universiti Kebangsaan Malaysia  
Jalan Yaacob Latif  
Bandar Tun Razak, Cheras  
56000 Kuala Lumpur  
Malaysia

All questions should be diverted to:  
Jabatan Radiologi  
Fakulti Perubatan UKM  
Tel : 03-91455555 samb. 6172, 6173  
Fax: 03-91456682

# CONTENT

Faculty Administration	4
Teaching Staff of the Department of Radiology	5
Faculty of Medicine: Vision, Mission & Objectives	7
The Programme (Master of Radiology UKM)	8
Programme Educational Objectives & Programme Learning Outcome	10
Course structure	11
Year 1	12
Year 2	24
Year 3	32
Year 4	34
Guidelines For Writing Case Report	35
Guidelines For Writing Project Proposal	36
Guidelines For Writing Research Manuscript	38
Guidelines For Project Research-Related Presentation	40
Workplace Based (Formative) Assessment (WPBA)	41
Clinico-Radiological Conference and Learning Activities	43
General Rules For Master Students	44
Guidelines for Medical Officer OnCall in the Dept of Radiology HCTM / HPKK	45
Graduates Assist	47

## FACULTY ADMINISTRATION

### **Dekan Fakulti Perubatan**

Profesor. Dr. Marina Mat Baki

### **Timbalan Dekan (Prasiswazah)**

Prof. Dr. Norazlina Bt Mohamed

### **Timbalan Dekan (Siswazah)**

Prof. Datin Dr. Norlinah Mohamed Ibrahim

### **Timbalan Dekan (Penyelidikan & Inovasi)**

Prof. Dr. Mohamad Nasir Shafiee

### **Timbalan Dekan Jaringan & Penjanaan**

Profesor. Datin Dr. Marina Mat Baki

### **Penolong Dekan Perkhidmatan Klinikal**

Prof. Dr. Syahrul Sazliyana Shahrir

### **Penolong Dekan Keusahawanan & Kreativiti**

Prof. Madya Dr. Mohd Helmy Mokhtar

### **Penolong Dekan Kualiti & Strategi**

Prof. Madya Dr. Teoh Seong Lin

### **Penolong Dekan Hal Ehwal Pelajar dan Alumni**

Dr Syamsa Rizal Abdullah

### **Penolong Dekan Pengajaran & Citra**

Dr Noor Akmal Shareela Ismail

### **Ketua Pentadbiran Sekretariat Pentadbiran Fakulti**

En. Zansyuwari Mohamad Shahrullail

### **Penolong Pendaftar (Pentadbiran) (Pengajian Prasiswazah)**

Pn. Rosmiza Musa

## TEACHING STAFF

**Department of Radiology, Faculty of Medicine, Universiti Kebangsaan Malaysia.**

### Head of Department

Assoc. Prof. Dr. Faizah Mohd Zaki

MD (UKM), MMed (Rad) (UKM), Fellowship in Paediatric Radiology (Toronto)

### Lecturers

Prof. Dr. Hamzaini Abdul Hamid

MBBCh (Ireland), MMed (Rad) (UKM), Fellowship in Paediatric Radiology (Toronto)

Assoc. Prof. Datin Dr. Shahizon Azura Mohamed Mukari

MBChB (Glasgow), MMed (Rad) (UKM), Fellowship in Neuroradiology (UM)

Assoc. Prof. Dr. Suraya Aziz

MBBS, BMedSci (Nottingham), MMed (Rad) (UKM)

Assoc. Prof. Dr. Kew Thean Yean

MBBS, BMedSci (Nottingham), MMed (Rad) (UKM)

Dr. Rizuana Iqbal Hussain

MBBS (Bangalore), MMed (Rad) (UKM)

Assoc. Prof. Dr. Nur Yazmin Yaacob

MBChB (Otago), MMed (Rad) (UKM)

Dr. Erica Yee Hing @ Wong [Clinical Master of Radiology Coordinator]

MBBS (UM), DrRad (UKM)

Dr. Mohd Imree Azmi

MBChB (Manchester), DrRad (UKM)

Dr. Aida-Widure Mustapha Mohd Mustapha

MBChB (Sheffield), DrRad (UKM)

Dr Leong Yuh Yang

MD (UKM), DrRad (UKM), FRCR UK, MMED NUS Sg, Fellowship in Interventional/Neurointerventional Radiology (UKM), Fellowship in Interventional Neuroradiology (NNI Sg)

Dr Nik Farhan Nik Fuad

MB BCh BAO (NUI), DrRad (UKM)

Dr Juliana Fairuz Maktar

MD (Moscow), DrRad (UKM)

Dr Emilia Rosniza Mohammed Rusli

MB BCh BAO (NUI), DrRad (UKM)

Dr Isa Azzaki Zainal

MD (UGM), DrRad (UKM)

Dr Ho Shuang Yee  
MD (RSMU Russia), MMed (Diagnostic Radiology) (NUS Singapore), FRCR UK

Dr Chai Jia Ning  
MBBS (UM), DrRad (UKM)

Dr Ani Anisa Basir  
MBBS (UM), DrRad (UKM)

Dr Izzat Arslan Che Ros  
MD (VSMU Russia), DrRad (UKM)

Dr Muhammad Aminuddin bin Ashari  
MB BCh BAO (NUIG), DrRad (UKM)

Dr Chong Chia Yin  
MBBS (Monash), DrRad (UKM)

Assoc. Prof. Dr. Hanani Abdul Manan  
M.Sc. Medical Physics (USM), PhD. Biomedicine (Neuroimaging) (UKM)

Dr. Mohamed Ariff Jaafar Sidek  
BSc (USA), Dip Edu, MSc (UK), PhD (UK)

**Department of Radiology, Faculty of Medicine, University of Malaya (Conjoint teaching)**  
All lecturers of the Department of Radiology, UM

**Part-time/Visiting Lecturers**

Dr Rozana Hussain - PhD. Medical Physics  
Dr Mohd Syahrir bin Yusop - MB BCh BAO (NUI), MMed Nuclear Medicine (UKM)  
Assoc. Prof. Kanaga Kumari Chelliah - Radiography

**Supervisors at Hospital Kuala Lumpur (HKL)**

Dr. Nurul Aida Selamat @ Keliwon  
Dr. Amali Ahmad  
Dr. Kartikasalwah Abd Latif  
Dr. Wendy Ng Yin Ling  
Dr. Hairuddin Achmad Sankala  
Dr. Afra Nashrini Ismail  
Dr. Dalila Badrul Hisham  
Dr. Ong May Ling  
Dr. Melisa Lim Seer Yee  
Dr. Salinawati Bakin  
Dr. Sarah Yaziz  
Dr. Mohd Shafiq Sulaiman

**Supervisors at Hospital Tunku Azizah (HTA)**

Dr. Nur Aishah Mohyin  
Dr. Wong Pik Li

# FACULTY OF MEDICINE UNIVERSITI KEBANGSAAN MALAYSIA

## **Vision**

To become a knowledgeable and competitive medical academy hub based on knowledge, innovation and a team of dedicated medical professionals in building a healthy and informed society.

## **Mission**

To provide education in medical professionals and high-quality services based on research, medical arguments, innovation and social sensitivity.

## **Objectives**

This program is conducted with the aim of producing doctors who are skilled in their field. While performing his main services to meet the health needs and demands of Malaysia, this doctor will be able to:

1. Use knowledge and skills and show the required attitude efficiently and wisely.
2. Engage in any medical specialization of his choice.
3. Work in any situation (hospital, health center and others) where applicable.
4. Identify and analyze health problems at the individual, family and community levels and solve these problems through health improvement, prevention, healing and rehabilitation by using resources carefully and effectively.
5. Show sensitivity to religious and moral values, customs and traditions of the community and respect them wherever they work.
6. Lead and act as an effective member of the health team.
7. Accept the fact that medical education is a lifelong process.

## 1. THE PROGRAMME

Name: Doctor of Radiology (Doktor Pakar Radiologi); DrRAD UKM

Venues:

1. Department of Radiology, Hospital Canselor Tuanku Muhriz (HCTM)
2. Department of Radiology, Hospital Tunku Ampuan Besar Tuanku Aishah Rohani, Hospital Pakar Kanak-Kanak UKM (HosTAR/HPKK)
3. Department of Diagnostic Imaging, Hospital Kuala Lumpur (HKL)
4. Department of Radiology, Hospital Tuanku Azizah (HTA), Kuala Lumpur

Method: Full time

Period : Minimum 4 years (8 semesters); Maximum 7 years (14 semesters)

PHASE	YEAR & SEMESTER
Phase 1	Year 1 – Semesters 1 & 2
<b>PART I EXAMINATION</b>	
Phase 2	Year 2 – Semesters 3 & 4
	Year 3 – Semesters 5 & 6
<b>PART II EXAMINATION</b>	
Phase 3	Year 4 – Semesters 7 & 8
<b>PART III EXAMINATION (EXIT EXAM)</b>	

Phase	Year/ Semester	Syllabus	Formative assessment	Summative assessment
Phase 1	Year 1 (Semesters 1 & 2)	<ul style="list-style-type: none"> <li>- imaging modality-based rotations</li> <li>- formal lectures covering all 3 components of radiology basics</li> <li>- Active and passive on-calls (angio)</li> </ul> 3 components of radiology basics: <ol style="list-style-type: none"> <li>1. Radiology physics, apparatus, film acquisition and film faults.</li> <li>2. Radiographic anatomy, trauma of the extremities</li> <li>3. Radiology techniques, contrast media and related drugs.</li> </ol>	R-IBA (x4) RPBA (x4) MSF (x1)	Part 1 exam (end of semester 2)
Phase 2	Year 2 (Semesters 3 & 4)	<ul style="list-style-type: none"> <li>- imaging modality-based rotations</li> <li>- formal lectures covering radiological pathologies of all the body systems</li> <li>- radiological procedures and theoretical knowledge in clinical radiology.</li> </ul>	R-IBA (x4) RPBA (x4) MSF (x1)	Part 2 exam (end of semester 6)
	Year 3 (Semesters 5 & 6)	<ul style="list-style-type: none"> <li>- TWO (2) case reports (1/year)</li> <li>- Submission of research proposal to ethics and conduct a research project</li> <li>- Active and passive on-calls</li> <li>- Presenting in weekly clinical-radiology conferences</li> </ul>	R-IBA (x4) RPBA (x4) MSF (x1) MDT (x2)	
Phase 3	Year 4 (Semesters 7 & 8)	<ul style="list-style-type: none"> <li>- Continues clinical rotation</li> <li>- On-calls</li> <li>- functions as a Registrar/ Junior Specialist and supervises the junior trainees</li> <li>- Active participation in clinical-radiology conferences</li> <li>- ONE (1) case report</li> <li>- Submission of a completed dissertation</li> </ul>	R-IBA (x4) RPBA (x4) MSF (x1) MDT (x2)	Part 3 exam (end of semester 8)

## 2. PROGRAMME EDUCATIONAL OBJECTIVES

The main goal of the study program is to increase the number of specialists in the field of Radiology. This program not only produces radiologists who are competent from a clinical and medical point of view, but also knowledgeable in research to address issues and challenges in the field of medicine at various levels of education.

The objectives of this program is to produce radiologists who:

PEO1: apply into practice the scientific knowledge and skills using digital technology in the field of radiology, for the improvement of patient care treatment methods.

PEO2: lead, communicate and interact effectively with stakeholders.

PEO3: competent in self-management, personal development and lifelong learning including innovation in the field of radiological medicine.

PEO4: exhibit ethical, professional behavior in career.

## 3. PROGRAM LEARNING OUTCOMES

1. Explain radiological medical knowledge in patient care.
2. Apply knowledge in the field of radiology and scientific approach as well as critical thinking in making decisions about patient treatment.
3. Perform clinical radiology procedures based on standard operating procedures.
4. Demonstrate the ability to interact and collaborate with various other professional teams.
5. Demonstrate how to effectively give oral and written advice.
6. Demonstrate skills in using digital technology in radiological medicine.
7. Using numerical skills in conducting research and patient care to improve knowledge in the field of radiology.
8. Demonstrate leadership qualities in leading a team and being able to make decisions in complex situations.
9. Exhibits good personal management skills in career.
10. Exhibit innovative nature in the field of radiology.
11. Exhibit medical ethics and act professionally throughout the patient treatment process.

#### 4. COURSE STRUCTURE

### KURSUS-KURSUS PROGRAM DOKTOR PAKAR RADIOLOGI

#### UNIVERSITI KEBANGSAAN MALAYSIA (UKM)

(Semakan kurikulum kelulusan 2022/2023)

	KOD KURSUS	KURSUS WAJIB	SEMESTER	JAM KREDIT
1	FFRD6119	TERAS RADIOLOGI I	1	9
2	FFRD6116	TERAS INTERVENSI RADIOLOGI I		6
3	FFRD6313	RADIOLOGI KLINIKAL I		3
4	FFFQ6611	PEMBANGUNAN KENDIRI & PROFESIONAL I		1
5	FFRD6129	TERAS RADIOLOGI II	2	9
6	FFRD6126	TERAS INTERVENSI RADIOLOGI II		6
7	FFRD6323	RADIOLOGI KLINIKAL II		3
8	FFFQ6621	PEMBANGUNAN KENDIRI & PROFESIONAL II		1
9	FFRD6139	RADIOLOGI KLINIKAL III	3	9
10	FFRD6236	INTERVENSI RADIOLOGI I		6
11	FFFQ6631	PEMBANGUNAN KENDIRI & PROFESIONAL III		1
12	FFRD6433	PENYELIDIKAN I: CADANGAN PENYELIDIKAN		3
13	FFRD6149	RADIOLOGI KLINIKAL IV	4	9
14	FFRD6246	INTERVENSI RADIOLOGI II		6
15	FFFQ6641	PEMBANGUNAN KENDIRI & PROFESIONAL IV		1
16	FFRD6159	RADIOLOGI KLINIKAL V	5	9
17	FFRD6256	INTERVENSI RADIOLOGI III		6
18	FFFQ6651	PEMBANGUNAN KENDIRI & PROFESIONAL V		1
19	FFRD6169	RADIOLOGI KLINIKAL VI	6	9
20	FFRD6266	INTERVENSI RADIOLOGI IV		6
21	FFFQ6661	PEMBANGUNAN KENDIRI & PROFESIONAL VI		1
22	FFRD6463	PENYELIDIKAN II: PENGURUSAN DATA		3
23	FFRD6179	RADIOLOGI KLINIKAL VII	7	9
24	FFRD6277	INTERVENSI RADIOLOGI V		7
25	FFFQ6671	PEMBANGUNAN KENDIRI & PROFESIONAL VII		1
26	FFRD6189	RADIOLOGI KLINIKAL VIII	8	9
27	FFRD6287	INTERVENSI RADIOLOGI VI		7
28	FFFQ6681	PEMBANGUNAN KENDIRI & PROFESIONAL VIII		1
29	FFRD6483	PENYELIDIKAN III: PENULISAN & PEMBENTANGAN DISERTASI		3
	<b>JUMLAH JAM KREDIT</b>			<b>145</b>

## YEAR 1

### OBJECTIVES

- Comprehensive grounding in all subjects related to the practice of Radiology or which provide the background to radiological interpretation.
- Preparation for the Part I Master of Medicine (Radiology) examination.
- Exposure to clinical radiology.

### SUBJECTS

- Section 1: Physics, Apparatus, Photography and Film Faults.
- Section 2: Plain Radiography and Radiographic Anatomy.  
Basic Musculoskeletal Trauma (Extremities).
- Section 3: Radiological Techniques which include contrast studies (fluoroscopy & angiography), ultrasonography, computed tomography (CT), isotope imaging, mammography, and magnetic resonance imaging (MRI); contrast media and related drugs.

### IMPLEMENTATION

#### Practical Training:

- Introductory rotations (Tagging)
- Medical officer roster (Modality-based clinical postings)
- On-call roster
- Clinical conferences
- Formative assessments: RIBA, RPBA, MSF

#### Lectures / Tutorials:

- 1 Formal lectures / tutorials:
  - a Sections 1, 2 & 3: Tuesdays 0800 – 1615 hrs
  - b Physics Tutorial / Practical Sessions
- 2 Revision sessions

### SYLLABUS

#### SECTION 1

#### Physics, Apparatus, Photography and Film Faults

---

##### 1 Fundamental Physics

Atomic structure: nucleus, electron shells, atomic number, mass number, nucleide, isotope,

electron energy, binding energy, the tungsten atom.

Electromagnetic radiation: spectrum

General Properties of X- and gamma-rays: wavelength, energy, wave vs quantum theory, inverse square law.

## **2 Radioactive Materials: General Properties**

Radioactivity: exponential decay, specific activity, physical biological and effective half-life, units of activity.

Radioactive decay process. Alpha, beta, gamma radiation – basic definition.

## **3 Production of X-rays:**

Essential components of X-ray tubes.

Thermionic emission, space charge effect, tube current, tube voltage, focal spot, line focus principle,

heel effect, heat capacity / tube rating.

Continuous spectrum, characteristic radiation. Factors influencing the X-ray spectrum: anode material, kV, mA, X-ray generator filtration.

## **4 Interaction of X-rays and Gamma-rays with matters and their effects on irradiated materials**

Interaction processes: Photoelectric and Compton. Their relative importance for various materials and at different energies, range of secondary electrons.

Effects: ionisation, excitation, heat, chemical biochemical, biological, photographic, fluorescence, phosphorescence, thermoluminescence.

## **5 Measurement of X-rays and gamma rays**

Quantity: Ionization

Exposure and exposure-rate meters: ionization chambers, condenser chambers, solid state / semiconductor detectors, TLD, film dosimetry.

Radionuclide detection, measurement, and spectrometry. Gas filled detectors: survey meters, dose calibrators, pocket/pen dosimeters, proportional counters, Geiger-Muller counters.

Scintillation detectors and photomultiplier tubes.

## **6 Attenuation of X-rays**

Quantity, quality, intensity, absorption vs scatter.

Exponential law, attenuation coefficient, half-value layer, factors affecting attenuation, monochromatic vs polychromatic radiation, beam hardening, filters.

Effect and control of scatter: beam restrictors, compression, grids, air gaps.

## **7 Image Receptors**

Intensifying screens: Structure, phosphor, intensification factor, speed vs. detail, resolution

sharpness, noise.

Conventional vs rare earth screens.

Films: Structure, characteristic curve, density vs. exposure, speed, contrast, latitude.

Film processing.

Image intensifier tube: Input and output screens, brightness gain, contrast, resolution, noise distortion.

II-TV systems: Fluoroscopy, cinefluorography.

Recording media: 35mm cine, 100mm spot films, video tape, multiformat camera, laser camera.

## **8 Radiological Image Quality**

Geometric factors: focal spot size, magnification, distortion, unsharpness.

Contrast: subject contrast, film contrast, fog and scatter.

Mottle/noise, sharpness, resolution: MTF, lp/mm.

## **9 Special Techniques**

Mammography: basic principles

Xeroradiography.

Conventional tomography: basic principles.

Radiographic subtraction, DSA.

## **10 Computed Tomography**

Basic components.

Types of scanning geometry: detectors, scan time.

Data collection: slice thickness, digitisation, projection data, linear attenuation coefficient and CT numbers, matrix pixel voxel.

Beam hardening and partial volume effects.

Image reconstruction.

Display: window width, window level, grey scale.

Image quality: resolution, contrast, noise, artefacts.

## **11 Radionuclide Imaging**

Radiopharmaceuticals: desirable properties, production of short half life materials.

Preparation of radiopharmaceuticals.

The gamma camera: principles and instrumentation.

Collimator, detector, photomultiplier tube, positioning circuitry, pulse height analyser, processor display.

Image quality: resolution, contrast, noise. Performance characteristics.

Introduction to PET, SPECT.

## **12 Radiation protection**

Radiation quantities and units: exposure, absorbed dose, equivalent dose, effective dose

Sources of radiation.

Biological effects of radiation: somatic and genetic effects, stochastic and deterministic effects.  
Tissue weighting factors, cancer and genetic risks.  
Objectives and principles of radiation protection. Recommendations of ICRP, ALARA. Dose limitations,  
annual limits of intake (ALI), derived working levels for airborne and surface contamination, absorbed  
dose to organs arising from radionuclide imaging.  
Legislation: radiation protection regulations.  
Protection of the patient, staff and the public in radiology and diagnostic nuclear medicine.  
Safe handling of radioactive materials.  
Radiation monitoring, personnel monitoring  
Radiation protection methods in specific procedures.

### **13 Ultrasound**

Wave properties: wavelength, frequency, velocity, intensity, power, decibel.  
Interaction of ultrasound with tissue: reflection, refraction, scattering and diffraction, absorption.  
Attenuation and TGC.  
Basic components. The transducer: piezoelectric properties, TGC, reception, amplification, signal processing display.  
Pulse and continuous wave ultrasound.  
Overview of scanning modes: A, B, M, real time, gated, Doppler, transmission mode display.  
Imaging parameters: pulse duration, PRF, ultrasonic field, axial resolution, lateral resolution, focusing, focal zone, dynamic range.  
Real time scanning, Doppler, colour Doppler.  
System performance.  
Artefacts, biological effects and hazards.

### **14 Magnetic Resonance Imaging**

Basic principles: tissue magnetization, Larmor frequency,  $T_1$ ,  $T_2$ , FID.  
Instrumentation: main magnet, shimming, RF coils, gradient coils, computer and display system, shielding.  
Basic imaging sequences: spin echo, inversion recovery, field/gradient echo, TE, TR.  
Concept of  $T_1$ ,  $T_2$  and proton density weighting.  
Image formation: gradient fields.  
The MR image: signal intensity, resolution, contrast, noise, and artefacts.  
System performance.  
Magnetic field hazards.

### **15 Other Topics**

#### **Digital Imaging and PACS**

Image acquisition systems.  
Digital radiography, imaging plate technology.  
Image storage and archiving, networking/communication systems, recording.  
Workstation: display and measurement functions, image processing.

## Quality Assurance

Methods of assessing image quality and their relationship to specifications of system performance

Methods of monitoring equipment performance.

Quality assurance of various systems.

## Radiography

Positioning of patients.

Standard radiographic projections.

Exposure factors, high kV techniques.

## SECTION 2 Plain Radiography and Radiographic Anatomy

---

### Important aspects of Plain Radiography:

- 1 Position of patient.
- 2 Location of film.
- 3 Orientation of planes and radiographic lines.
- 4 Position and angulation of tube.
- 5 Type of film screen-film combination/Digital detector plate/CR Reader
- 6 Focus film distance
- 7 Exposure factors (kVp, mAs).
- 8 Centering points.

### 1 Skull and Facial Bones:

Standard	:	PA, lateral
Pituitary fossa	:	Coned views, PA, lateral, Towne's,
Orbit	:	PA, lateral, three point landing for optic canal
IAM	:	per orbital, Towne's, SMV,
Mastoid bone	:	lateral, lateral oblique, Towne's
TM Joints	:	PA open and closed mouth.
Jugular foramen	:	SMV 70°
Paranasal sinuses	:	OM, lateral, PA
Nasopharyngeal space	:	lateral, SMV

### 2 Spine

Cervical spine	:	Standard	AP, lateral
		Atlanto-axial joints } subluxation }	AP open-mouth view Lateral in flexion and extension
		Intervertebral foramina	Oblique
		Lower cervical spine	Swimmer's view

Thoracic spine	:	Standard	AP, lateral
Lumbosacral spine	:	Standard Intervertebral foramen, apophyseal joints, } pars interarticularis	AP, lateral  Oblique
Sacroiliac joints	:	AP obliques, PA	

### 3 Neck

Soft tissue neck	:	AP, lateral
Larynx	:	AP, lateral

### 4 Chest

Standard	:	PA erect
Subpulmonic effusion	:	Decubitus
Localisation of lesions	:	Lateral
Middle lobe disease	:	Lordotic view
Apical lesions	:	Apical lordotic view
Ribs, pleural effusion	:	Oblique
Small pneumothorax, foreign bodies	:	PA in inspiration and expiration.

### 5 Abdomen

Standard	:	AP supine
Air-fluid levels, pneumoperitoneum	:	Erect, decubitus
Differentiate gallstones from renal stones	:	Oblique
Relationship of calcification to kidneys	:	Inspiration and expiration

### 6 Upper extremities

Shoulder joints	:	AP, transthoracic, axillary
Humerus	:	AP, lateral
Elbow joint	:	AP, lateral, view for radial head
Radius and ulna	:	AP, lateral
Wrist and carpal bones	:	AP, lateral, oblique, views for scaphoid bone

### 7 Lower Extremities

Hip joints	:	AP
Femoral neck	:	AP, lateral oblique, lateral
Femur	:	AP, lateral
Knee joint	:	AP, lateral
Tibia and fibula	:	AP, lateral

Ankle joint	:	AP, lateral
Foot	:	AP, oblique

## 8 Basic Musculoskeletal trauma of extremities (Upper limbs and lower limbs).

### SECTION 3 Contrast Studies, CT, MRI, Ultrasound and Isotope Imaging (Techniques and Radiographic Anatomy), Contrast Media and Related Drugs

---

#### Important aspects in radiological procedures:

- 1 indications and contraindications
- 2 patient preparation
- 3 requirements - equipment, contrast media and use of drugs
- 4 technique - radiological and radiographic
- 5 complications
- 6 after care

#### 1 Contrast Media in Radiology

Types of contrast media.  
 Pharmacology and excretion of contrast media.  
 Side effects and contrast media reactions and their treatment.

#### 2 Drugs in Radiology

Preparation of bowel.  
 Sedation before radiological procedures.  
 Prophylaxis and treatment of contrast media reactions.  
 Drugs used during radiological procedures.

#### 3 Vascular Imaging

- a General aspects of conventional and digital subtraction angiography (DSA)
  - Angiographic equipment
  - Patient preparation
  - Needles, catheters, guide wires, contrast media
  - Puncture sites
  - Image recording
  - Complications
- b Ultrasound (imaging and Doppler), CTA, MRA, radionuclide scintigraphy

#### 4 Central Nervous System

CT of the brain  
 CT of the pituitary gland  
 CT & MR myelography of the spine  
 MRI of the brain

MRI of the pituitary gland  
MRI of the spine  
Internal carotid artery angiography  
Vertebral artery angiography

## **5 ENT and Ophthalmology**

CT base of skull  
CT of paranasal sinuses  
CT of the nasopharyngeal and parapharyngeal spaces  
CT of the orbit  
MRI of internal auditory canal  
MRI base of skull  
MRI nasopharyngeal and parapharyngeal spaces  
MRI of the orbits  
Common and external carotid artery angiography  
Jugular venography

## **6 Neck**

CT and MRI of the neck  
CTA, MRA  
Ultrasound of the thyroid/parathyroid

## **7 Urinary system**

Intravenous urography  
Antegrade pyelography  
Retrograde pyelography  
Micturating cystourethrography  
Ascending urethrography  
Ultrasound of the kidneys and bladder  
CT of the urinary system  
Angiography of the kidneys  
CTA, MRA

## **8 Gastrointestinal system**

Plain AXR  
Barium studies  
Angiography - Coeliac, SMA, IMA  
CT of the bowel

## **9 Hepatobiliary system, pancreas and spleen**

Plain AXR  
Oral cholecystogram  
PTC/PTBD  
ERCP  
Ultrasound  
CT  
MRI  
Angiography

## Splenoportography

### 10 Musculoskeletal system

US  
CT  
MRI

### 11 Angiographic anatomies

Arch aortogram  
Upper limb  
Free flush aortogram  
Pelvic angiography  
Lower limb angiography, venography; lymphangiography

### 12 Radionuclide imaging

Skeletal system  
Hepatobiliary system  
Urinary system  
Thyroid  
Gastrointestinal system

### 13 Interventional radiology

Biopsy procedures  
Aspiration and drainage procedures  
Balloon dilatation and stenting, embolisation etc.

### 14 Miscellaneous

Hysterosalpingography  
Sialography  
Dacryocystography  
Arthrography,  
Fistulography, etc.

## EXAMINATION

- Part 1 Examination for the Doctor of Radiology will be held the following year in May at the end of Phase I. Logbook has to be handed in to be eligible to register for examination.
- **The examination consists of 4 components:**
  - a **Objective Structured Practical Examination (OSPE)**
    - 2 OSPE stations, 15 minutes each
    - Practical questions are related to radiological procedures

- b 1 Multiple Choice Questions (MCQ) paper:**
  - Consists of section 1 (physics), 2 (radiological anatomy) & 3 (radiological technique)
  - Each section has 20 questions, total 60 questions.
  - 2- hour paper.
- c Objective Structured Clinical Examination (OSCE)**
  - 20 film exhibits will be given in a 60-minute session
  - Questions are related to radiography, radiographic anatomy, radiological techniques, and physics.
- d Viva Voce**
  - Station A - Section 1 (physics); 2&3 (anatomy & technique) 30 minutes
  - Station B - Section 2 & 3 (anatomy & technique) 30 minutes

- **Formulation of marks:**

The marks for each component consisting of OSPE, MCQ, OSCE and Viva Voce are calculated as percentages.

- **Requirements for passing:**

Obtain a percentage of at least 50% in each component.

Candidate who has passed one or more components in the Part I examination shall be deemed to have passed those components and shall not be required to repeat those components in the following attempts.

- **Candidate who fails the Part 1 at first attempt:**

- does not continue into the next stage of the programme and will be extended 6 months.
- shall be permitted a re-sit in the next examination 6 months later.
- shall be required to repeat those components that he/she has failed in the Part I examination.

- **Number of attempts permitted to pass Part 1 examination:**

- Candidates are allowed a maximum of TWO (2) YEARS to pass the Part 1 examination.
- A maximum number of **THREE (3) attempts** are allowed in the 2-year period.
- Candidates who do not pass the Part 1 examination within 2 years will **LEAVE** the course.

## READING LIST

### Essential Reading Materials

1. **Anatomy for Diagnostic Imaging**  
Stephanie Ryan (Saunders Ltd.)
2. **Weir & Abrahams' Imaging Atlas of Human Anatomy**

Jonathan D. Spratt (Elsevier)

3. **Chapman & Nakielnny's Guide to Radiological Procedures**  
Nick Watson (Elsevier)
4. **Farr's Physics for Medical Imaging**  
Alim Yucel-Finn (Elsevier)
5. **Accident and Emergency Radiology: A Survival Guide**  
Nigel Raby (Saunders Ltd.)
6. **The Chest X-Ray: A Survival Guide**  
Gerald de Lacey (Saunders Ltd.)

### **Recommended Reading Materials**

1. **Applied Radiological Anatomy**  
Paul Butler (Cambridge University Press)
2. **Essentials of Radiologic Science**  
Robert Fosbinder, Denise Orth (Lippincott Williams & Wilkins)
3. **Christensen's Physics of Diagnostic Radiology**  
Thomas S. Curry III (Lea & Febiger)
4. **MRI Made Easy (for Beginners)**  
Govind B Chavhan (Jaypee Brothers Medical Publishers Pvt Ltd)
5. **MRI in Practice**  
Catherine Westbrook (Wiley-Blackwell)
6. **Bontrager's Handbook of Radiographic Positioning and Techniques**  
John Lampignano (Mosby)

### **Useful Websites with Free Learning Materials**

1. **Radiology Café**  
<https://www.radiologycafe.com/>
2. **FRCR Academy**  
<https://frcrademy.co.uk/>
3. **My Lightbulb Moments – Royal College of Radiologist**  
<https://www.rcr.ac.uk/cpd-and-events/rcr-learning-hub/my-lightbulb-moments/>
4. **Musculoskeletal MRI**  
<https://www.freitasrad.net/>
5. **Stanford MSK MRI Atlas**  
<http://xrayhead.com/>

**6. Radiology Learning London – Physics videos**

<https://radiologylearninglondon.com/physics/>

**7. MRI Made Easy (...well almost)**

Hans H. Schild

<https://www.radiology.bayer.com/academy/mri-made-easy>

## YEAR 2

### OBJECTIVES

- Formal teaching on basic interpretation of radiographic abnormalities covering all aspects of imaging e.g. plain radiography, contrast studies, ultrasonography and computed tomography of various systems. Some exposure to these abnormalities and preliminary knowledge of their interpretation should have been gained through performing radiological procedures during the First Year itself.
- Further accumulation of practical experience in radiological procedures and theoretical knowledge in clinical radiology.
- Preparation for the Part II Master of Medicine (Radiology) examination.

### SUBJECTS

Clinical Radiology covering all aspects of imaging of various systems in the body.

### IMPLEMENTATION

- Formal lectures / tutorials on Thursdays 1400 – 1700 hours
- Daily work with radiological procedures.
- Attendance at clinico-radiological sessions.
- Informal supervision and discussion in the course of performing radiological procedures and formulating a radiology report.
- Participate in Emergency Calls.
- Project proposal and conduct a research
- Formative assessment: RIBA, RPBA, MSF

### LECTURES / TUTORIALS:

#### 1. EXTRACRANIAL HEAD AND NECK

Paranasal sinuses/ orbit  
Temporal bone/ ear  
Neck spaces  
Supra/infrathyoid lesions

#### 2. PAEDIATRIC

##### Brain

Neonatal Brain Injury (preterm vs term)  
Common developmental and congenital abnormalities  
Neurocutaneous syndrome  
Infection  
NAI

##### Spine

spinaldysraphism and low lying cord

## **Neck**

Cystic / solid neck masses  
Retinoblastoma

## **Chest**

Diffuse pulmonary disease in newborn (surfactant deficiency disease, TTN, MAS, neonatal pneumonia)  
Focal pulmonary lesion in newborn  
Lucent vs solid lesion  
Assesment of lines and tubes  
Chronic lung disease of prematurity  
Infections in infants and older children

## **Musculoskeletal**

NAI  
Tumours  
Infection

## **Abdomen**

NEC  
High/low intestinal obstruction  
Intraabdominal calcification  
Vomitting infant  
Acute abdomen  
Neonatal jaundice  
Hydronephrosis in a child

### **3. BREAST**

Pattern of calcification  
Mass : benign vs malignant  
Density  
Birads calcification  
MRI

### **4. OBSTETRIC AND GYNAECOLOGY**

Tumours  
Infection  
Gravid and non-gravid uterus  
Ectopic pregnancy

### **5. VASCULAR**

Aneurysm  
Atherosclerosis  
Fibromuscular dysplasia  
Arteriovenous malformation  
Embolism  
Pattern of vascular trauma/injury  
Pseudoaneurysm/ graft/ DVT

### **6. INTERVENTIONAL RADIOLOGY**

Basic principal  
Cases

Complication

## 7. LIVER

Tumour – enhancement pattern and physiology

HCC

Metastasis

Hypervascular lesions

Haemangioma

Cholangiocarcinoma

Benign liver tumours

Diffuse liver disease

Abscess

## 8. PANCREAS AND SPLEEN

The biliary tract – stricture benign vs malignant

Calcification – pancreas/liver/spleen

Pancreas- tumours, cyst. Hypervascular lesion

## 9. GENITOURINARY SYSTEM

### Kidney

Renal – mass (RCC, TCC, AML)

Cyst ( bosniak)

Infection

**PC system** – obstruction/mass (TB)

**Bladder, prostate, testis** (MRI prostate)

## 10. GASTROINTESTINAL SYSTEM

Pattern recognition

Stricture : benign vs malignant

Thickening : benign vs malignant

\*contrast study/CT

Polyps & nodules (filling defect)

Pneumoperitoneum signs

Bowel dilatation/obstruction – how to approach

Enhancement pattern of bowel wall thickening

### Diseases

UC & Crohns

Tumours/infection (TB, pseudomembranous)

Investigation of GI haemorrhage – findings/signs

### Misc

Peritoneal disease

Nodules

Omental caking

Myxedema

Retroperitoneal lesion – fibrosis, lipoma

## 11. NEURORADIOLOGY

## **Ischaemia**

Pathophysiology and radiopathological correlation of arterial vs venous, watershed

## **Vascular**

Evolution of haematoma

## **Vascular malformation- pathology**

**Trauma** – herniation syndrome

## **Infectious and non-infectious/inflammatory**

Routes of infection, diffuse vs focal

Anatomically bounded infectious process

Common infection (viral, bacterial etc)

## **Demyelination**

Primary : MS

Secondary

## **Tumours**

Lesion characterization

Intra vs extra axial

cortical, parenchymal, lepto/pachymeningeal

periventricular

Advance neuro eg dwi/spectroscopy/perfusion

Intratumoural haematoma vs benign intracranial haematoma

## **Sellar, CPA**

## **Spine**

Lesion localization

Common lesion

Extradural, intramedullary

Vascular malformation

## **12. CHEST**

### **Pattern recognition**

To identify lesion in various spaces

Mediastinum

Pleural

Lung – tumour vs infection

Extra thoracic

### **Pattern recognition**

Lung disease

Alveolar

Interstitial

Airway

- Plain radiograph
- HRCT appearance eg GGO/mosaic/tree in bud etc

Diseases of the Mediastinum/ pleura

Tumour/infection

Diseases of the Airways

Diffuse lung diseases

Chest trauma; the post-operative chest; intensive care; radiation chest trauma

### **Heart**

Radio-pathological correlation

CCF

PVH

PAH

Valvular heart disease

Infarct – CTA/MR cardiac

## **13. MUSCULOSKELETAL SYSTEM**

### **Infection**

Pathophysiology, Radiological features (Plain radiograph, MRI, CT, Nuclear Medicine, Ultrasound),

Routes of Spread, Stages of **Osteomyelitis**

Terminology (Sequestrum, Involucrum, Cloca)

Brodie Abscess

Multifocal

Septic Arthritis

Spondylodiscitis

Soft tissue infection

### **Bone Tumours**

Imaging Features (Primarily Radiographic)

Size

Location

Margin/Zone of Transition

Aggressiveness/Growth Pattern DDX-Infection

Internal Characteristics

Pattern of Osteolysis

Matrix/Calcification

Involvement of Adjacent Structures

Benign/

Malignant

Primary or Secondary Bone Tumours (i.e. radiation, Pagets)

### **Soft Tissue Tumours**

(MRI characteristics primarily)

Lipoid

Fibrous

Cartilaginous

Neural

Muscle

Vascular

Miscellaneous

Primary

Secondary  
Leukaemia  
Lymphoma

## **Arthropathies**

### General

1. Distribution
2. Soft Tissue Changes
3. Joint Space Narrowing
4. Bone Density
5. Osteophyte
6. Subchondral Cysts
7. Erosions
8. Proliferative New Bone
9. Joint Deformity
10. Calcification

### Subtypes

Osteoarthritis

Inflammatory arthritis

Rheumatoid Arthritis

Psoriatic Arthritis

Ankylosing Spondyloarthritis

Enteropathic Spondyloarthropathy

Juvenile Chronic Arthritis

Crystal associated

-Gout

-Calcium Pyrophosphate Deposition Disease (CPPD)

Connective Tissue Disease (SLE, Scleroderma, Dermatomyositis, Polymyositis)

Miscellaneous

Haemochromatosis

PVNS

Synovial chondromatosis

### **Shoulder**

Rotator Cuff Impingement, Degeneration and Tear

Glenohumeral Dislocation, Instability and Labral Tears

### **Elbow**

Ligaments and tendons- Sprains and Tears

### **Wrist**

Triangular Fibrocartilage Complex Injury

### **Hip**

Femoroacetabular Impingement and Labral Tears

### **Knee**

Meniscal Injuries

Cruciate Ligament Injuries

Collateral Ligament Injuries

Tendon Injuries

Chondral Cartilage Injuries

### **Ankle**

Ligaments and tendons- Sprains and Tears

Osteochondral injuries

## **Fractures**

Emphasis of Spine Fractures/Dislocation

## **Miscellaneous**

### **Metabolic Disorders**

- 1)Osteoporosis
- 2)Hyperparathyroidism
- 3)Thyroid Diseases
- 4)Rickets and Osteomalacia
- 5)RenalOsteodystrophy

### **Haematogenous Disorders**

- 1)Thalassemia
- 2)Hemophilia
- 3)Myelofibrosis
- 4)Marrow reconversion
- 5)Extramedullaryhematopoiesis

### **Osteonecrosis**

- 1)Causes
- 2)Site specific Disease

### **Common congenital /dysplastic conditions**

Achondroplasia  
OsteogenesisImperfecta  
Osteopetrosis  
Melorrheostosis  
Mucopolysaccharidoses  
Tarsal coalition

## **READING LIST (Year 2 & 3)**

### **Essential Reading Materials**

1. **Chapman & Nakielny's Aids to Radiological Differential Diagnosis**  
Hameed Rafiee (Elsevier)
2. **Rapid Review of Radiology**  
Shahid Hussain (CRC Press)
3. **Aunt Minnie's Atlas and Imaging-Specific Diagnosis**  
Thomas L Pope Jr. (LWW)

### **Recommended Reading Materials**

1. **Grainger & Allison's Diagnostic Radiology: 2-Volume Set**  
Andy Adam (Elsevier)

2. **Radiology Review Manual**  
Wolfgang F. Dahnert (LWW)
3. **Fundamentals of Skeletal Radiology**  
Clyde A. Helms (Elsevier)
4. **Fundamentals of Pediatric Imaging**  
Lane F. Donnelly (Academic Press)
5. **Felson's Principles of Chest Roentgenology, A Programmed Text**  
Lawrence R. Goodman (Elsevier)
6. **Neuroradiology: The Requisites (The Core Requisites)**  
David M. Yousem (Elsevier)
7. **Top 3 Differentials in Radiology: A Case Review**  
William T. O'Brien (Thieme)
8. **Atlas of Normal Roentgen Variants That May Simulate Disease**  
Theodore E. Keats (Saunders)

### Useful Websites

1. **Radiology Assistant**  
<https://radiologyassistant.nl/>
2. **Radiology Café**  
<https://www.radiologycafe.com/>
3. **Café Roentgen**  
<https://caferoentgen.com/>
4. **FRCR Academy**  
<https://frcracademy.co.uk/>
5. **STATdx**  
Access through UKM Library website  
<https://eresourcesptsl.ukm.remotexs.co/user/login>
6. **Journal Articles** – RSNA, AJR etc.

## YEAR 3

### OBJECTIVES

- To gain further experience in performing radiological procedures and in radiographic interpretation. To attain a level of expertise and skill such that the candidate is able and reasonably confident to work, discuss and formulate decisions independently most of the time.
- To further accumulate and consolidate knowledge in clinical radiology. To attain a reasonable standard to pass the Part II examination that will be held at the end of the year or session.
- To prepare for the Part II Master of Medicine (Radiology) examination.

### SUBJECTS

Clinical radiology.

### IMPLEMENTATION

- Formal lectures / tutorials on Fridays 1430 – 1700 hours
- Daily work with radiological procedures and supervise juniors.
- Present at clinico-radiological sessions.
- Informal supervision and discussion while performing radiological procedures and formulating a radiology report.
- Lead the Emergency Calls.
- Conduct on-going research
- Formative assessment: RIBA, RPBA, MDT, MSF
- Conduct Journal club

### TUTORIAL SESSIONS

Weekly formal tutorial sessions.

### EXAMINATION

- PART 2 examination will be held at the end of Year 3 (in May/November). Logbook to be handed in to head of department (HOD) before registration for examination.
- The examination consists of 3 components:
  - a **Single Best Answer (SBA) (2 papers)**
    - Each paper contains 100 questions, 2 hour 30 minutes
  - b **Film Reporting (FR)**
    - 8 questions containing various images, 1 hour 20 minutes
  - c **Viva voce:**
    - 2 stations of clinical radiology questions containing various images, 30 minutes / station

- Criteria for passing the Part 2 examination:
  - i. The passing mark for SBA component is based on standard settings set by the Conjoint Board of Radiology in every exam, and 50% for viva voce and film reporting.
  - ii. Candidates are required to pass all components to pass the examination.
- A candidate who has passed one or more of the components of the Part 2 examination shall be deemed to have passed those components and shall not be required to repeat those components in the following attempts.
- Candidate who fails the Part 2 examination at the first attempt will not proceed to Year 4 and shall be extended 6 months.
- The candidate shall be permitted a re-sit in the next examination 6 months later. He/she will be required to repeat those components that he/she has failed in Part 2 exam.
- A maximum number of **THREE (3) attempts** are permitted for Part 2 examination.

## READING LIST

Please refer Year 2 Reading List

## YEAR 4

### OBJECTIVES

This course strengthens the radiology knowledge and practice. Students will act as a registrar/ junior specialist and supervisors to the junior trainees. As a registrar, the trainee will participate actively in the clinical radiology sessions/radiology conferences with other discipline and take more responsibility in day-to-day clinical postings.

### SUBJECTS

Clinical radiology

### IMPLEMENTATION

- Conventional procedures (+ supervision of junior trainees)
- On-Call duty roster
- Active participation in the clinico-radiological sessions.
- Further experience on special radiological techniques and procedures such as ultrasound, CT, angiography, interventional procedures and MRI.
- Formative assessment: R-BA, RPBA, MDT, MSF
- Conduct journal clubs
- Completion of Case Reports and Projects:
  - A total of 3 Case Reports are required to be written over the 4-year period.
  - Case and Project Reports (dissertations) are to be submitted 3 months before the end of the academic session.

### EXAMINATION

- Rapid film reporting, assessment of Case Reports and Project Report (Dissertation) are components of the Part 3 examination.
  - The assessment of project reports will be done by a panel consisting of internal examiners.
  - Rapid film reporting is conducted at the end of year 4 in May/November.
  - Logbook to be handed in to the HOD before registration of exam.
- Candidate must pass all components to be awarded DrRAD UKM.
- Candidate who fails shall be extended 6 months or a shorter duration as recommended by the supervisor.
- A maximum number of **THREE (3) attempts** are permitted for Part 3 examination.

## GUIDELINES FOR WRITING CASE REPORTS

- 1 As a guide, the following are examples of suitable cases to report:
  - i) A rare case.
  - ii) A common case with atypical manifestation.
  - iii) A Case(s) to demonstrate the complementary role of the various imaging modalities.
  - iv) A Case(s) to illustrate the limitation of a particular imaging modality.
  - v) A Case(s) to highlight the discovery of new radiological findings.
  - vi) A Case(s) to report the use of a new technique.
- 3 A maximum of 1500 words is allowed.  
Use only standard abbreviations. The full term for which an abbreviation stands for should precede its first use in the text unless it is a standard unit of measure.
- 4 A maximum of 5 images is preferred. More than 5 illustrations may be allowed if it is deemed necessary. Images should be of good resolution and non-distorted. All illustrations and diagrams should be referred to as figures and numbered in Arabic numerals. All figures should be fully labelled so that each is comprehensible without reference to the text.
- 5 Only 1 table is allowed.  
The table should be in double spacing and numbered with the Roman numerals. Omit internal horizontal and vertical rules. The table should be fully labelled so as to be comprehensible without reference to the text.
- 6 A maximum of 10 references may be quoted.  
Number references consecutively in the order in which they are first mentioned in the text. Use the form of references adopted by the journal you plan to submit.
- 7 The style of printing (size of paper, spacing, margins, font size, etc) should be as indicated by the guideline from journal you plan to submit.
- 8 The report should be written under the following sub-headings:
  - i) TITLE
  - ii) ABSTRACT:  
A summary of the entire report in not more than 100 words.
  - iii) INTRODUCTION:  
A short review of the subject with references where relevant. Clearly state the purpose of the case report.
  - iv) CASE REPORT:
    - (1) Relevant information on history, physical examination and biochemistry.
    - (2) A detailed description of the radiological investigation.
    - (3) For cases that have undergone surgery, include:
      - (a) operative findings.
      - (b) histopathological examination (HPE) findings.
      - (c) illustration of the intra-operative findings, gross specimen and/or HPE findings.
  - v) DISCUSSION:  
The main body of the discussion should relate to the purpose of the case report.
  - vi) REFERENCES:  
According to the journal you plan to submit.
- 9 Case reports should be submitted to Puan Inaliza **within 6 months** after presentation at department level.

## CONTENTS OF THE PROJECT PROPOSAL

### 1. INTRODUCTION

Briefly introduce the subject.

Give only strictly pertinent references and do not review the subject extensively.

Summarize the rationale for the study.

Clearly state the purpose of the study (general objective).

e.g.

- This study is a review of the stereotactic biopsy of nonpalpable breast lesions.

### 2. OBJECTIVES

List the main and specific objectives of the study.

e.g.

- To determine the indications for mammography in the patients who underwent stereotactic biopsy.
- To obtain the demographic profile (age, ethnic group, menarche, menopause, parity and positive family history) of the patients who underwent stereotactic biopsy.
- To determine the histology of the biopsies in relation to the mammographic appearance.
- To determine the site of carcinoma of the breast.
- To determine the positive predictive value, negative predictive value, sensitivity and specificity of stereotactic biopsy of nonpalpable breast lesions.
- To review the methods of stereotactic biopsy used from 1997 to 2000.
- To determine the complications of stereotactic biopsy.

### 3. LITERATURE REVIEW

This should be an extensive review of every aspect of the subject.

e.g.

- Breast Carcinoma: Risk Factors.
- Breast Carcinoma: Pathology.
- Interpretation of the Mammogram.
- The nonpalpable breast lesion: Lesions that require biopsy.
- Techniques of stereotactic biopsy.

The sources of all information should be included under REFERENCES.

### 4. METHODOLOGY

Organize the methodology under sub-headings.

e.g.

- Study Design
- Study Population (Patient selection criteria. Patient exclusion criteria).
- Study Period & Location
- Equipment and Technique
- Data Collection.
- Statistical Analysis.

### 5. REFERENCES

List the references according to the sequence that they were referred to in the report.

The style of writing the references should follow the journal you plan to submit.

6. APPENDIX

e.g. Consent forms in Malay and English (Prospective), Data Sheet, Budget, if necessary, etc.



## CONTENTS OF THE MANUSCRIPT

Please consult your supervisor for the template of the journal you want to submit to prior to writing.

### 1. INTRODUCTION

Briefly introduce the subject.

Give only strictly pertinent references and do not review the subject extensively.

Summarize the rationale for the study.

Clearly state the purpose of the study (general objective).

e.g.

This study is a review of the stereotactic biopsy of nonpalpable breast lesions.

### 2. OBJECTIVES

List the specific objectives of the study.

e.g.

- To determine the indications for mammography in the patients who underwent stereotactic biopsy.
- To obtain the demographic profile (age, ethnic group, menarche, menopause, parity and positive family history) of the patients who underwent stereotactic biopsy.
- To determine the histology of the biopsies in relation to the mammographic appearance.
- To determine the site of carcinoma of the breast.
- To determine the positive predictive value, negative predictive value, sensitivity and specificity of stereotactic biopsy of nonpalpable breast lesions.
- To review the methods of stereotactic biopsy used from 1997 to 2000.
- To determine the complications of stereotactic biopsy.

### 3. METHODOLOGY

Organize the methodology under sub-headings.

e.g.

- Study Design
- Study Population (Patient selection criteria. Patient exclusion criteria).
- Study Period & Location
- Equipment and Technique
- Data Collection.
- Statistical Analysis.

### 4. RESULTS

You should include the whole study's findings. Comments on the significance of the results should be saved for the Discussion section.

Present the data in relevant tables and figures (with good annotations). The tables and figures format best follows the guideline from the journal you want to submit to. A glimpse of previous published original article from the same journal can be your guideline.

### 5. DISCUSSION

The key point in the discussion is to:

- Summarize the key findings in clear and concise language.
- Acknowledge when a hypothesis may be incorrect and suggest possible cause or explanation.
- Place your study within the context of previous studies. You need to quote a lot of previous related literature and state if it is concordant or discordant and explain why if it is discordant.

- Discuss potential future research.
- Provide the reader with a “take-away” statement to end the manuscript.

## 5. REFERENCES

List the references according to the sequence that they were referred to in the report. The style of writing the references should follow **the journal you want to submit to.**

## 6. APPENDIX

e.g. Consent forms (prospective study), diagram if necessary, etc.

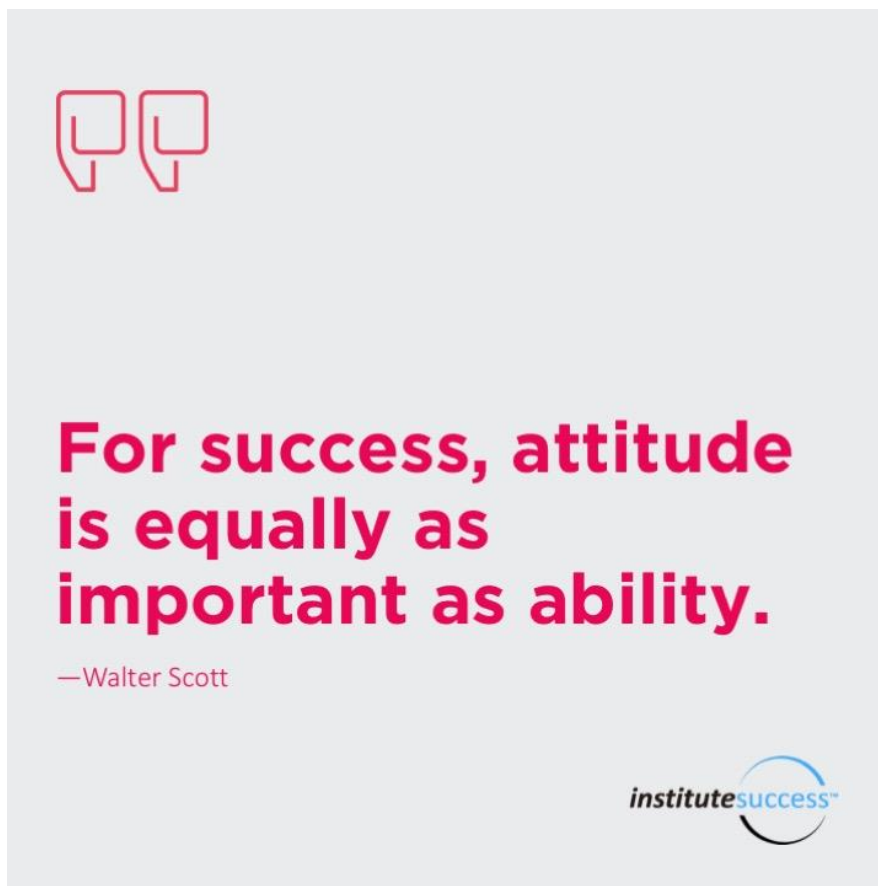

## GUIDELINES FOR PROJECT RESEARCH-RELATED PRESENTATION

### **PROJECT PROPOSAL** (Beginning of Year 2)

1. Title – name, supervisor(s)
2. Introduction
3. General Objective
4. Specific Objective
5. Hypothesis, null hypothesis
6. Methodology including sample size, flow chart, data collection sheet
7. Literature review
8. Gantt Chart
9. Budget
10. References

After presentation of project proposal, student need to submit their proposal to Ethical Committee for approval and FF number – **please do this by the end of Year 2**

### **PRELIM PROJECT PRESENTATION** (Beginning of Year 4)

1. Title including FF no. - Ethical committee approval
2. Brief introduction
3. Brief objective
4. Brief methodology, sample size with flow chart
5. Data collection – please show data proforma or table, demographics
6. Statistical Analysis

(Failure to present with Data / Statistical Analysis / FF no. may result in penalization of marks, re-presentation or 6-months extension – subject to decision of the panel of examiners)

Dissertation sent to supervisor after completion of data collection and analysis in complete **journal manuscript** form (to be decided between candidate and supervisor)

Submission of dissertation in **journal manuscript** form to examiners **prior** to viva defense

### **VIVA DEFENSE** (Year 4)

1. Title including **FF no.**
2. Brief introduction, objective, methodology
3. **Data with statistical analysis**
4. **Discussion**
5. **Abstract**
6. **References**

Corrected dissertation should be sent to **supervisor** before submission for fulfillment of completing Dr RAD

## WORKPLACE-BASED / FORMATIVE ASSESSMENT (WPBA)

WPBA is an assessment strategy consisting of assessments in the workplace in addition to the traditional examinations of knowledge and clinical skills.

### Learning Agreements

At the beginning of the training programme, and during every subsequent posting/placement, the trainee and supervisor will sign a learning agreement i.e. a contract which both sides must fulfil. This details the learning activities a trainee must undergo throughout his/her training. The learning agreement sets out what the trainer/institution offers for training, so the trainee can understand the direction that their learning will take. The learning agreement will be discussed and documented at the beginning of training, following the induction process, to facilitate training and formative assessment activities. The learning agreement is described in greater detail in Instruments of Assessment below.

### Formative assessments

Formative assessment to support the trainee in their learning using the following tools:

- Radiology- Imaging based Assessment (R-IBA)
- Radiology Procedural based Assessment (R-PBA)
- Multi-Disciplinary teamwork assessment (MDT)
- Multi-Source Feedback (MSF)
- Logbook
- Supervisor's (SV) report

FORMATIVE ASSESSMENT	Frequency/time period	Total throughout the program
Learning agreement	3x/ 4years	3
R-IBA	2x/ 1 semester	16
R- PBA	2x/ 1 semester	16
MDT	1x/ 1 semester	4
MSF	1x/ 1 year	4
SV report	1x/ 1 semester	8
Logbook	1x/Phase	3

## Summary of WPBA along the course of programme

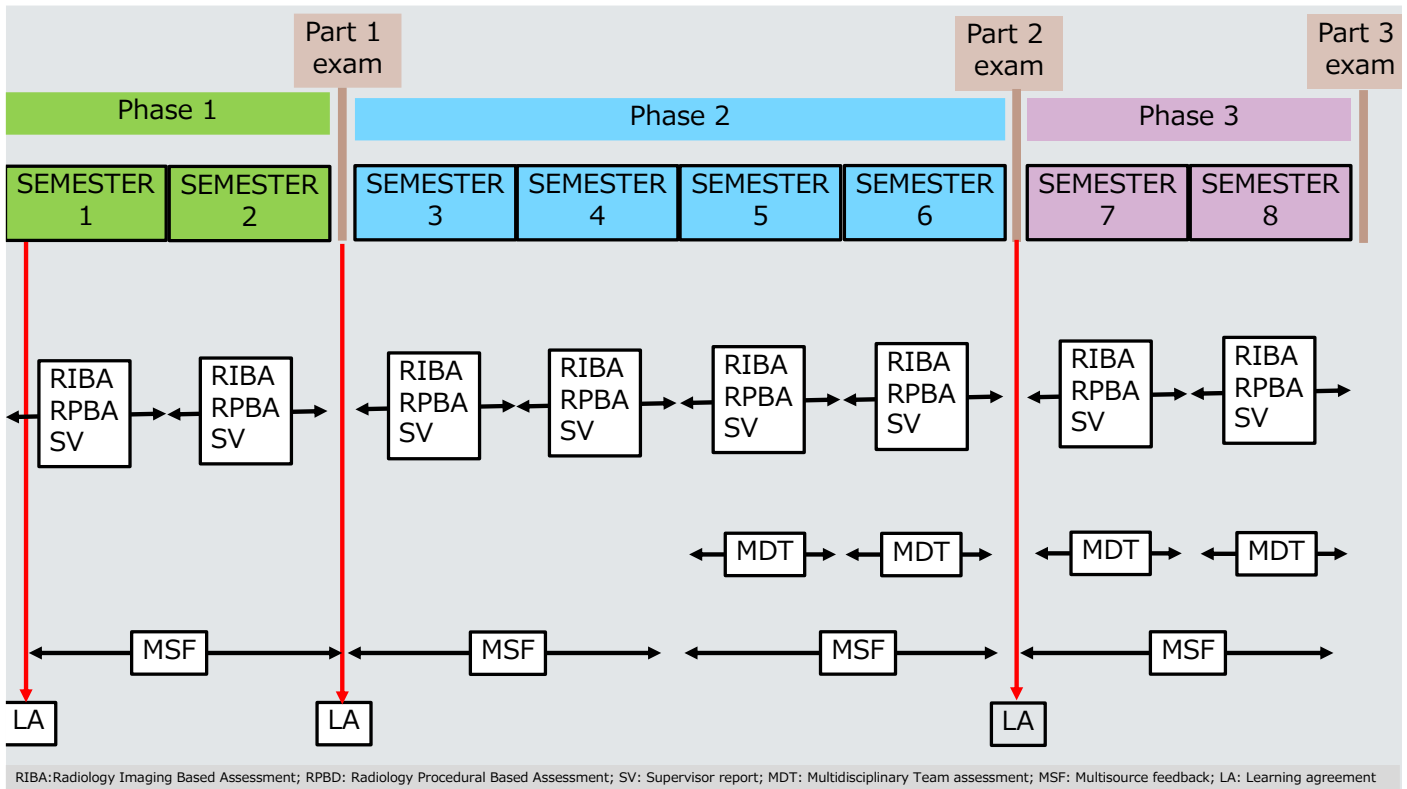

## CLINICO-RADIOLOGICAL CONFERENCES AND LEARNING ACTIVITIES

<b>Monday</b>	0800 - 0900	Medical
	1000 - 1100	Neurosurgery
	1430 - 1600	Case report presentation
<b>Tuesday</b>	0800 - 0900	ENT
	1400 - 1500	Neuromedical
	1430 - 1530	Paediatric Surgery
	1400 - 1500	Inflammatory bowel disease (monthly)
<b>Wednesday</b>	0800 - 0900	Faculty CPC (Clinico-pathological conference) Vascular surgery
	1200 - 1300	Breast imaging (fortnightly)
	1300 - 1400	Journal club
<b>Thursday</b>	0800 - 0900	Surgery
	0900 - 1000	Gastrohepatology
	1100 - 1200	Orthopaedics
<b>Friday</b>	0800 - 0900	Paediatric Medical
	0900 - 1000	Colorectal (fortnightly)
	1430 - 1600	Uroradiology (monthly)

### Please note:

- Clinico-radiological conferences will also be available in Hospital Kuala Lumpur (HKL) and Hospital Tuanku Azizah (HTA). Please refer to person in-charge of the relevant training centres.
- Clinico-radiological conference day & time are subject to change depending on current situations.

## GENERAL RULES FOR MASTER STUDENTS

### CLASS ATTENDANCE

Attendance should be 100% in formal conjoint classes. Failing to achieve this, student can be extended.

### LEAVES:

- 1) 1 SEMESTER – 14 days semester leave + 1 week radiation leave
- 2) No medical leave allowed – MC has to be deducted from radiation leave
- 3) Radiation leave 1 week – either taken consecutively for 7 days (inclusive of weekends and public holidays), or 3 days – 2 days if separated.
- 4) No regional festive (non-KL) leaves
- 5) No paternal or formal maternity leaves
- 6) Pregnant master students are not entitled for radiation leave
- 7) Study leave – deducted from semester leave
  - i) Part 1 & Part 2 first timers: 2 weeks (inclusive of weekends & public holidays) prior to exam week
  - ii) Part 1 & Part 2 repeaters: 1 week prior to the component he/she is sitting for
  - iii) Part 3 rapid reporting: 3 working days before RR exam
- 8) During study leave and exam weeks, **leave is frozen by default for covering batches**, which include all students not sitting for exam. Violation will result in punishment.
- 9) Study leave is a privilege, not entitlement. It may be withdrawn any time at the discretion of the department / HOD.
- 10) Leaves may be frozen also during other known periods of shortage at the discretion of the department / HOD.
- 11) Leave forms need to be submitted to Encik Fazli Izwan (Wan) before the leave starts.

### ATTENDING CONFERENCES:

- 1) Students are encouraged to attend local or international conferences, and are most encouraged to present oral or poster presentations during these conferences.
- 2) Unrecorded leave allowance for attending conferences: max 3 days / year. Need to fill up form and apply; subject to approval by the head of department.
- 3) If your oral or poster presentation is accepted in an international conference, you are eligible to apply for travel grant from ALUMNI RADIOLOGI UKM (subject to terms and conditions).

### PROGRAM DEFERMENT

Part 1 examination – if a student is unable to perform or assist in radiological procedures involving radiation exposure (e.g. fluoroscopy, angiography etc.) for 8 months or more due to pregnancy or other reasons in year 1 (semesters 1 & 2), the student needs to defer and will not be allowed to sit for Part 1 examination during semester 2.

### OTHERS

- 1) It is the student's responsibility to renew Annual Practicing Certificate (APC) yearly. A valid digital copy should be submitted to Puan Zalifah before the year starts. Without APC, you are not allowed to work in the department, and may need to defer the semester and exam.
- 2) Please make sure you have HCTM, HosTAR (HPKK), HKL and all facilities under KKM listed when you apply for APC every year, regardless of your posting during the time of application.
- 3) If a student gets warning letters or official complaints for 3 times or more, he or she can be extended.

## GUIDELINES FOR MEDICAL OFFICER ONCALL IN THE DEPARTMENT OF RADIOLOGY HCTM/HPKK

No.	Activity																																							
1	Oncall in HCTM will require 2 active MO and 1 passive MO Oncall in HPKK will require 1 active MO																																							
2	Active on-call means MO has to be available in the hospital at all time from: Weekdays : 5PM - 8AM (the next morning) Weekends : 8AM - 8AM (the next morning)																																							
3	Passive on-call means MO may stay at home but have to be on standby and always ready at a moment's notice to be called and come to the hospital within 15 minutes. Among the job specification for passive on-call MO: <ol style="list-style-type: none"> <li>1. Perform evening rounds for angiography cases</li> <li>2. Assisting or performing with supervision for angiography cases</li> <li>3. Reporting radiographs during weekends/public holidays call.</li> <li>4. Any job specification stated by the radiologist on-call</li> </ol>																																							
4	Passive oncall claims can be only be given if MO standby for less than 4 hours																																							
5	If passive oncall MO has to be in the hospital during oncall period for more than 4 hours, MO is eligible to claim passive-active																																							
6	<table border="1" style="width: 100%; border-collapse: collapse; text-align: center;"> <thead> <tr> <th rowspan="3">JENIS KADAR Rate Type</th> <th colspan="2">KADAR SEHARI</th> <th rowspan="3">JENIS HARI Day Type</th> <th rowspan="3">KETERANGAN Description</th> </tr> <tr> <th colspan="2">Rate per day</th> </tr> <tr> <th>PAKAR PERUBATAN</th> <th>PEGAWAI PERUBATAN</th> </tr> </thead> <tbody> <tr> <td>A</td> <td>100</td> <td>80</td> <td>HARI BEKERJA Work days</td> <td>PANGGILAN PASIF (<i>PASSIVE CALL</i>) BERTUGAS KURANG DARIPADA 4 JAM</td> </tr> <tr> <td>B</td> <td>105</td> <td>85</td> <td>HUJUNG MINGGU DAN CUTI AM Weekends &amp; public holidays</td> <td>Work less than 4 hours</td> </tr> <tr> <td>C</td> <td>150</td> <td>130</td> <td>HARI BEKERJA Work days</td> <td>PANGGILAN PASIF (<i>PASSIVE CALL</i>) BERTUGAS MELEBIHI 4 JAM</td> </tr> <tr> <td>D</td> <td>160</td> <td>140</td> <td>HUJUNG MINGGU DAN CUTI AM Weekends &amp; public holidays</td> <td>Work more than 4 hours</td> </tr> <tr> <td>E</td> <td>230</td> <td>200</td> <td>HARI BEKERJA Work days</td> <td>PANGGILAN AKTIF (<i>ACTIVE CALL</i>) BERTUGAS DI LUAR WAKTU BEKERJA BIASA MELEBIHI 15 JAM SECARA BERTERUSAN</td> </tr> <tr> <td>F</td> <td>250</td> <td>220</td> <td>HUJUNG MINGGU DAN CUTI AM Weekends &amp; public holidays</td> <td>Work more than 15 hours continuously excluding office hours</td> </tr> </tbody> </table>	JENIS KADAR Rate Type	KADAR SEHARI		JENIS HARI Day Type	KETERANGAN Description	Rate per day		PAKAR PERUBATAN	PEGAWAI PERUBATAN	A	100	80	HARI BEKERJA Work days	PANGGILAN PASIF ( <i>PASSIVE CALL</i> ) BERTUGAS KURANG DARIPADA 4 JAM	B	105	85	HUJUNG MINGGU DAN CUTI AM Weekends & public holidays	Work less than 4 hours	C	150	130	HARI BEKERJA Work days	PANGGILAN PASIF ( <i>PASSIVE CALL</i> ) BERTUGAS MELEBIHI 4 JAM	D	160	140	HUJUNG MINGGU DAN CUTI AM Weekends & public holidays	Work more than 4 hours	E	230	200	HARI BEKERJA Work days	PANGGILAN AKTIF ( <i>ACTIVE CALL</i> ) BERTUGAS DI LUAR WAKTU BEKERJA BIASA MELEBIHI 15 JAM SECARA BERTERUSAN	F	250	220	HUJUNG MINGGU DAN CUTI AM Weekends & public holidays	Work more than 15 hours continuously excluding office hours
JENIS KADAR Rate Type	KADAR SEHARI		JENIS HARI Day Type	KETERANGAN Description																																				
	Rate per day																																							
	PAKAR PERUBATAN	PEGAWAI PERUBATAN																																						
A	100	80	HARI BEKERJA Work days	PANGGILAN PASIF ( <i>PASSIVE CALL</i> ) BERTUGAS KURANG DARIPADA 4 JAM																																				
B	105	85	HUJUNG MINGGU DAN CUTI AM Weekends & public holidays	Work less than 4 hours																																				
C	150	130	HARI BEKERJA Work days	PANGGILAN PASIF ( <i>PASSIVE CALL</i> ) BERTUGAS MELEBIHI 4 JAM																																				
D	160	140	HUJUNG MINGGU DAN CUTI AM Weekends & public holidays	Work more than 4 hours																																				
E	230	200	HARI BEKERJA Work days	PANGGILAN AKTIF ( <i>ACTIVE CALL</i> ) BERTUGAS DI LUAR WAKTU BEKERJA BIASA MELEBIHI 15 JAM SECARA BERTERUSAN																																				
F	250	220	HUJUNG MINGGU DAN CUTI AM Weekends & public holidays	Work more than 15 hours continuously excluding office hours																																				
7	<p>E-warga UKM documentation has to be provided as evidence for the oncall claim</p> <p>Weekdays: Active and Passive - Log in at 8AM day 1 and log out BEFORE 8AM the next day (day 2). Log in again for day 2 at 8AM and log out at 5PM at day 2. Do not log out at 5PM on day 1</p> <p>Weekends: Active and Passive - Log in at 8AM day 1 and log out at 8AM the next day (day 2) if day 2 is a holiday. If day 2 is a working day (weekdays), practice as weekdays log in/out.</p>																																							
8	Passive oncall MO needs to fill in the Passive Oncall Record for documentation to																																							

	capture more than 4 hours availability in the hospital. <a href="https://tinyurl.com/PassiveCallRecordRadiology">https://tinyurl.com/PassiveCallRecordRadiology</a>
9	All oncall claims must be done online via <a href="https://oncall.ukm.my/">https://oncall.ukm.my/</a>
10	Staff claims received after the 5th of the month will be paid in the following month's salary.
11	Any claim that more than 2 months will not be processed.



Success is no accident.  
It is hard work, perseverance,  
learning, studying, *sacrifice*,  
and MOST of all,  
*love of what you are doing.*  
-Pele

NOTES